



STORAGE SYSTEMS

SOLVING YOUR STORAGE NEEDS

STANLEY

Vidmar[®]

STANLEY

Vidmar®

Stanley® Vidmar® Modular Storage Cabinets

Store 5 shelving units of inventory in just 2 Stanley® Vidmar® storage cabinets and save approximately 50% of your storage space.

Flexibility is key to any Vidmar® modular cabinet. Drawers can be interchanged if needed; and partitions and dividers can be moved or added, so you can build just the right size compartments to fit your inventory needs.

Combine this with superior quality construction — drawers with 400-lb. capacity each, a unique locking system for security, and a built-in pallet base to move the cabinet even when fully loaded* — and you get a return on investment that's unmatched.

Replacing traditional shelving with Stanley® Vidmar® modular cabinets can save you approximately 50% of the space you're currently using to inventory your tools, parts, fasteners, fittings, and other equipment.

*Cabinets must be locked and banded prior to moving.

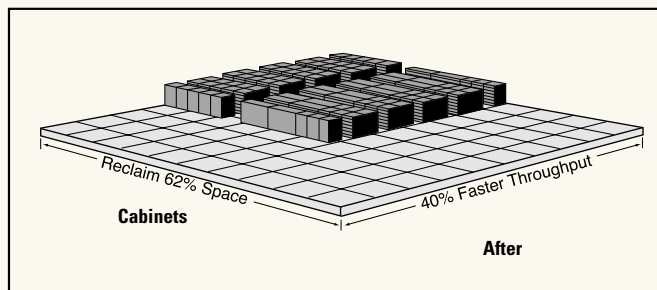
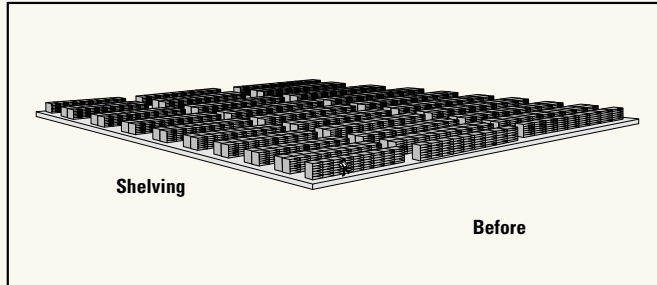

VI

Visit us at...
www.stanleyvidmar.com

HOW A CABINET IS BUILT

CABINET FEATURES

The Most Popular Storage Drawer Cabinet Configurations

Six cabinet heights, 15 drawer heights, and 103 of the most popular drawer interiors are all combined into 128 of the most popular and versatile storage drawer cabinet configurations in use today.

Cabinet housings are the basis for the entire cabinet system. The welded housings support the loaded cabinet while maintaining drawer cycling and longevity. Stanley® Vidmar® cabinet housings conform to the transportation industry's Rule180, promoting better handling and simplifying damage claims. These heavy-duty steel housings are available in 10 standard colors and eight footprints. A built-in pallet base makes cabinets easily moveable, even when fully loaded (loaded cabinets must be banded and/or locked before moving).

Housings will support cabinets stacked up to six high, so you can make use of wasted vertical space. Six heights are available, ranging from 27 in. (686 mm) desk height to 59 in. (1499 mm) eye level.











1. Housing

Each Redi-Pak cabinet starts with one of eight cabinet housing sizes. Redi-Pak housings are available in four heights. Each height receives a model number:

- 27 in. high - Model 135**
- 30 in. high - Model 155**
- 33 in. high - Model 175**
- 37 in. high - Model 245**
- 44 in. high - Model 200**
- 59 in. high - Model 340**

So if you need a Standard cabinet that is 59 in. high, the model number for the cabinet would be Standard cabinet Model 340.

Cabinets are available in ten standard colors.

	Off White S22570
	Beige S20100
	Vidmar Green S20606
	Hunter Green S50091
	Light Blue S22577
	Bright Blue S22447
	Dark Blue S22578
	Red S50054
	Vidmar Gray S23321
	Black S20106

1.



Standard
30 in. W x 27-3/4 in. D
(762 mm W x 705 mm D)



Shallow Depth
30 in. W x 21-3/8 in. D
(762 mm W x 543 mm D)

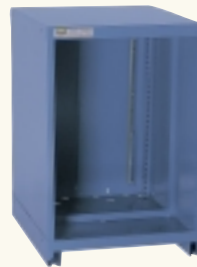

Small Version
22-1/2 in. W x 27-3/4 in. D
(572 mm W x 705 mm D)



Small Version Shallow Depth
22-1/2 in. W x 21-3/8 in. D
(572 mm W x 543 mm D)



Extra Wide
45 in. W x 27-3/4 in. D
(1143 mm W x 705 mm D)



Extra Wide Shallow Depth
45 in. W x 21-3/8 in. D
(1143 mm W x 543 mm D)



Double Wide
60 in. W x 27-3/4 in. D
(1524 mm W x 705 mm D)



Double Wide Shallow Depth
60 in. W x 21-3/8 in. D
(1524 mm W x 543 mm D)

2. Drawers

The next step to building a cabinet is the drawers. Like the model number given to each housing height, the drawers also have model numbers ranging from Model 20 up to Model 90. Each drawer model number represents a different drawer height. For additional drawer heights contact your Stanley® Vidmar® Customer Service Representative at 800-523-9462. When reviewing the cabinets, the drawer model numbers are shown on the left side of each cabinet in red. If you add up all the drawer model numbers for each cabinet, the sum total must equal the cabinet height model number. Thus, if you have a Standard cabinet Model 340 (59 in. high) with the below seven drawer model numbers, the sum total of those drawer model numbers should equal the 340 Model number used for the height of the cabinet. If the total sum of the drawer model numbers does not equal the cabinet height model number, then the drawers will not fit in the cabinet housing. (See Below)

Drawer Model Numbers	Useable Height
40	(5-3/8 in.)
50	(7 in.)
50	(7 in.)
50	(7 in.)
50	(7 in.)
50	(7 in.)
+50	(7 in.)

Standard cabinet Model 340

3. Partitions and Dividers

The partition and divider setup used to build compartments in each drawer is referred to as a "Loading Diagram". Each Loading Diagram is also given its own number. Loading Diagram numbers are listed on the right side of each cabinet in black. Each section featuring the housing sizes listed includes the most popular Loading Diagrams for that housing. Cabinets are shipped with all partitions and dividers installed.

4. Locks

All cabinets with drawers are fitted with a single key lock system that opens all drawers. To order cabinets without locks, delete the "L" suffix from the model number.



2.

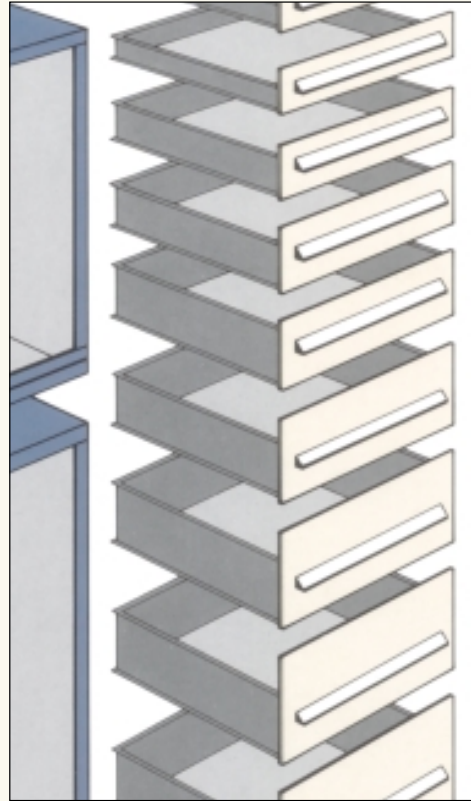
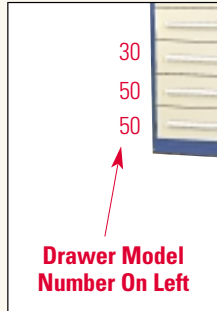

3.

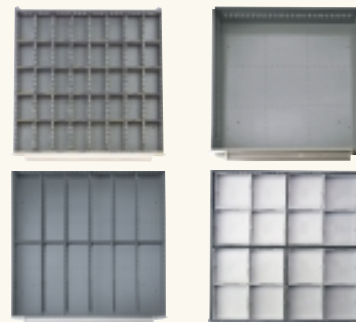
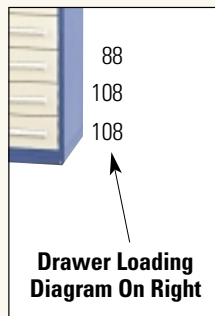

4.

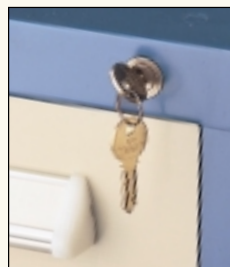

To protect inventory, the Stanley® Vidmar® keying system is virtually impossible to duplicate.

HOW A CABINET IS BUILT

STANDARD DRAWER FEATURES

Standard Drawer Features

- Drawer sizes are designed around average human reach (25-1/8 in. square [638 mm]) for easy access.
- Drawer heights range from 2-1/4 to 13-1/4 in. (57 to 336 mm) usable height. (Intermediate and larger drawer sizes are also available. Call 800-523-9462 for details.)
- Drawers hold up to 400 lbs (181 kg).
- Drawers glide easily on a ball-bearing carriage system which is guaranteed against failure.
- Drawers are interchangeable with other drawers in cabinet housings of the same style.
- Each drawer has slotted walls for partitions and dividers, providing infinite configurations.
- Each drawer pull has a large label and plastic shield for quick, easy-to-read identification of contents.
- A variety of label holders are available to identify individual compartments within the drawer.

Drawers Usable Heights

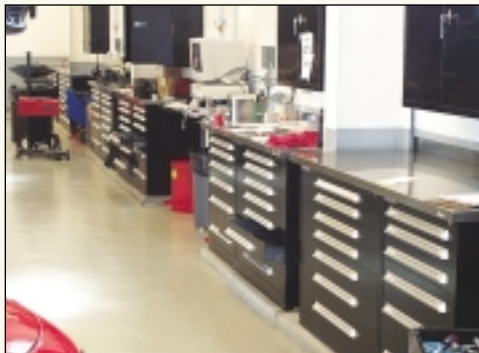
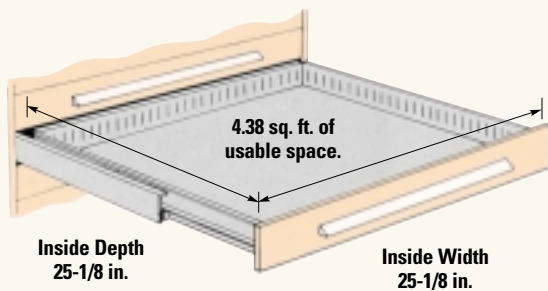

MODEL#	USABLE HEIGHT	
	IN.	(MM)
20	2-1/4 in.	(57 mm)
25	3 in.	(76 mm)
30	3-7/8 in.	(98 mm)
35	4-5/8 in.	(117 mm)
40	5-3/8 in.	(137 mm)
45	6-1/4 in.	(159 mm)
50	7 in.	(178 mm)
55	7-3/4 in.	(197 mm)
60	8-1/2 in.	(216 mm)
65	9-3/8 in.	(240 mm)
70	10-1/8 in.	(257 mm)
75	10-7/8 in.	(276 mm)
80	11-3/4 in.	(292 mm)
85	12-1/2 in.	(318 mm)
90	13-1/4 in.	(337 mm)

PRE-CONFIGURED CABINETS

EYE LEVEL HEIGHT

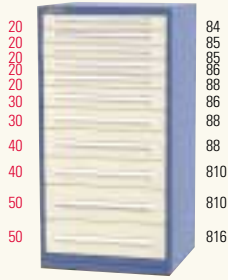

RP3092AL
11 Drawers
200 Compartments
Usable Drawer Heights
2-1/4 in. (57 mm)
3-7/8 in. (98 mm)
5-3/8 in. (137 mm)
7 in. (178 mm)

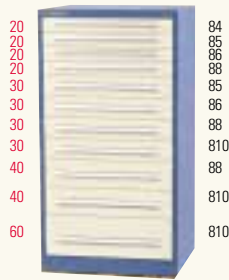

RP3098AL
11 Drawers
204 Compartments
Usable Drawer Heights
2-1/4 in. (57 mm)
3 in. (76 mm)
5-3/8 in. (137 mm)
8-1/2 in. (216 mm)

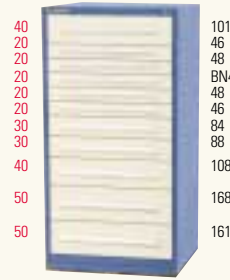

RP3404AL
11 Drawers
275 Compartments
Usable Drawer Heights
2-1/4 in. (57 mm)
3-7/8 in. (98 mm)
5-3/8 in. (137 mm)
7 in. (178 mm)



SCU3079AL
11 Drawers
224 Compartments
Usable Drawer Heights
3 in. (76 mm)
3-7/8 in. (98 mm)
5-3/8 in. (137 mm)



SCU3067AL
11 Drawers
216 Compartments
Usable Drawer Heights
3-7/8 in. (98 mm)
5-3/8 in. (137 mm)

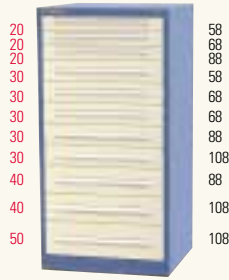

SEP3306AL
11 Drawers
192 Compartments
Usable Drawer Heights
2-1/4 in. (57 mm)
3-7/8 in. (98 mm)
5-3/8 in. (137 mm)
7 in. (178 mm)

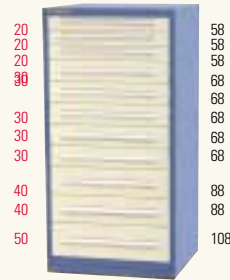

SCU3306AL
11 Drawers
216 Compartments
Usable Drawer Heights
2-1/4 in. (57 mm)
3-7/8 in. (98 mm)
5-3/8 in. (137 mm)
7 in. (178 mm)

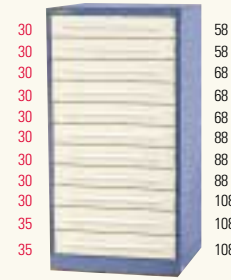

SEP3062AL
11 Drawers
192 Compartments
Usable Drawer Heights
3-7/8 in. (98 mm)
4-5/8 in. (117 mm)

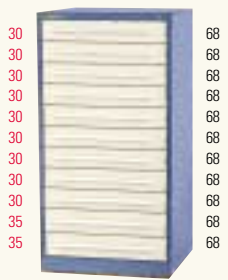

SCU3062AL
11 Drawers
220 Compartments
Usable Drawer Heights
3-7/8 in. (98 mm)
4-5/8 in. (117 mm)

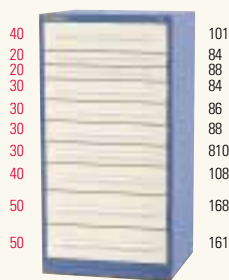

RP3406AL
10 Drawers
163 Compartments
Usable Drawer Heights
3-7/8 in. (98 mm)
2-1/4 in. (57 mm)
7 in. (178 mm)
5-3/8 in. (137 mm)

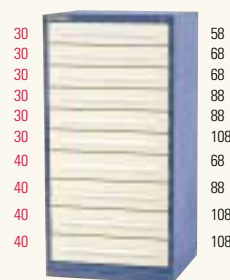

SEP3110AL
10 Drawers
164 Compartments
Usable Drawer Heights
3-7/8 in. (98 mm)
5-3/8 in. (137 mm)

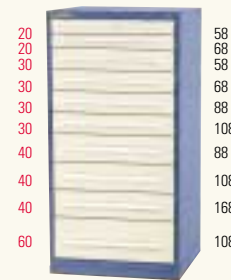

SEP3126AL
10 Drawers
164 Compartments
Usable Drawer Heights
2-1/4 in. (57 mm)
3-7/8 in. (98 mm)
5-3/8 in. (137 mm)
8-1/2 in. (216 mm)



Eye Level Height Continued

Model 340

59 in. (1499 mm) high
30 in. (762 mm) wide
27-3/4 in. (705 mm) deep

To order cabinets without locks, delete the "L" suffix from the model number (example: SEP1001AL becomes SEP1001A).

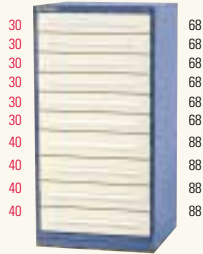
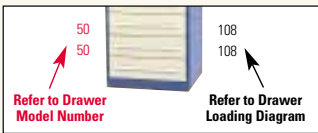

SCU3110AL
10 Drawers
184 Compartments
Usable Drawer Heights
3-7/8 in. (98 mm)
5-3/8 in. (137 mm)

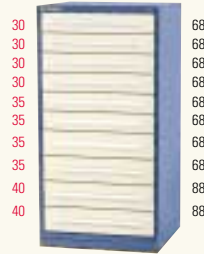

SCU3108AL
10 Drawers
192 Compartments
Usable Drawer Heights
3-7/8 in. (98 mm)
4-5/8 in. (117 mm)
5-3/8 in. (137 mm)

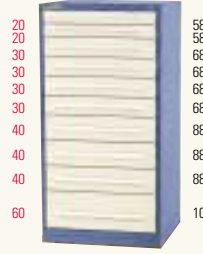

SCU3126AL
10 Drawers
188 Compartments
Usable Drawer Heights
2-1/4 in. (57 mm)
3-7/8 in. (98 mm)
5-3/8 in. (137 mm)
8-1/2 in. (216 mm)

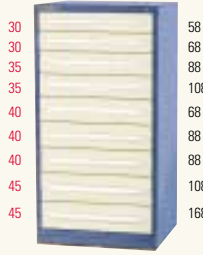

SEP3140AL
9 Drawers
144 Compartments
Usable Drawer Heights
3-7/8 in. (98 mm)
4-5/8 in. (117 mm)
5-3/8 in. (137 mm)
6-1/4 in. (159 mm)

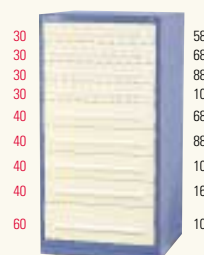

SEP3144AL
9 Drawers
140 Compartments
Usable Drawer Heights
3-7/8 in. (98 mm)
5-3/8 in. (137 mm)
8-1/2 in. (216 mm)

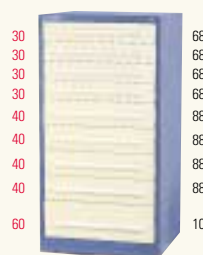

SCU3144AL
9 Drawers
156 Compartments
Usable Drawer Heights
3-7/8 in. (98 mm)
5-3/8 in. (137 mm)
8-1/2 in. (216 mm)

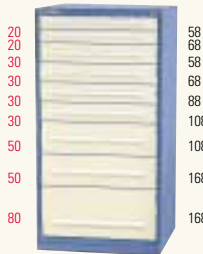

SEP3155AL
9 Drawers
144 Compartments
Usable Drawer Heights
2-1/4 in. (57 mm)
3-7/8 in. (98 mm)
7 in. (178 mm)
11-3/4 in. (292 mm)

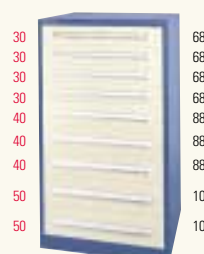

SCU3352AL
9 Drawers
152 Compartments
Usable Drawer Heights
3-7/8 in. (98 mm)
5-3/8 in. (137 mm)
7 in. (178 mm)

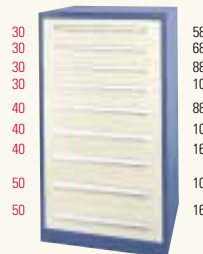

SEP3352AL
9 Drawers
128 Compartments
Usable Drawer Heights
3-7/8 in. (98 mm)
5-3/8 in. (137 mm)
7 in. (178 mm)

PRE-CONFIGURED CABINETS

EYE LEVEL HEIGHT



SEP3157AL
8 Drawers
112 Compartments
Usable Drawer Heights
5-3/8 in. (137 mm)
6-1/4 in. (159 mm)

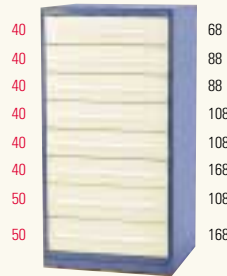

SEP3163AL
8 Drawers
104 Compartments
Usable Drawer Heights
5-3/8 in. (137 mm)
7 in. (178 mm)

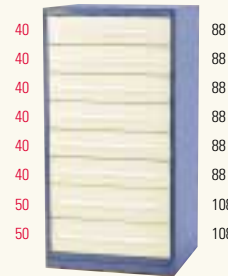

SCU3163AL
8 Drawers
120 Compartments
Usable Drawer Heights
5-3/8 in. (137 mm)
7 in. (178 mm)



SEP3371AL
8 Drawers
100 Compartments
Usable Drawer Heights
3-7/8 in. (98 mm)
5-3/8 in. (137 mm)
7 in. (178 mm)
8-1/2 in. (216 mm)

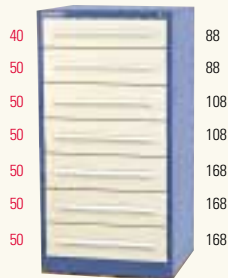

SEP3189AL
7 Drawers
80 Compartments
Usable Drawer Heights
5-3/8 in. (137 mm)
7 in. (178 mm)

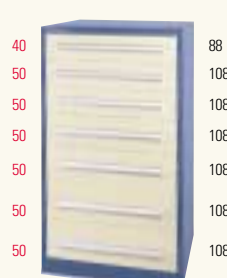

SCU3189AL
7 Drawers
88 Compartments
Usable Drawer Heights
5-3/8 in. (137 mm)
7 in. (178 mm)

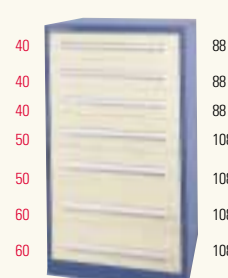

SCU3389AL
7 Drawers
96 Compartments
Usable Drawer Heights
5-3/8 in. (137 mm)
7 in. (178 mm)
8-1/2 in. (216 mm)



SEP3203AL
6 Drawers
64 Compartments
Usable Drawer Heights
6-1/4 in. (159 mm)
7 in. (178 mm)
8-1/2 in. (216 mm)
11-3/4 in. (292 mm)



SCU3398AL
6 Drawers
72 Compartments
Usable Drawer Heights
7 in. (178 mm)
8-1/2 in. (216 mm)



SCU3399AL
5 Drawers
52 Compartments
Usable Drawer Heights
5-3/8 in. (137 mm)
8-1/2 in. (216 mm)
10-1/8 in. (257 mm)
11-3/4 in. (292 mm)
13-1/4 in. (337 mm)

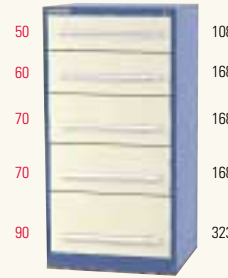

SEP3214AL
5 Drawers
37 Compartments
Usable Drawer Heights
7 in. (178 mm)
8-1/2 in. (216 mm)
10-1/8 in. (257 mm)
13-1/4 in. (337 mm)

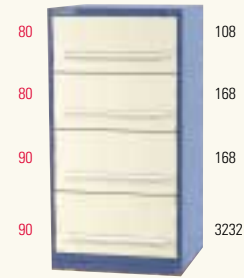

SEP3219AL
4 Drawers
29 Compartments
Usable Drawer Heights
11-3/4 in. (292 mm)
13-1/4 in. (337 mm)



SEP2004AL
 11 Drawers
 248 Compartments
 Usable Drawer Heights
 2-1/4 in. (57 mm)
 3 in. (76 mm)
 3-7/8 in. (98 mm)



SEP2012AL
 10 Drawers
 200 Compartments
 Usable Drawer Heights
 2-1/4 in. (57 mm)
 3 in. (76 mm)
 3-7/8 in. (98 mm)



SEP2025AL
 9 Drawers
 184 Compartments
 Usable Drawer Heights
 2-1/4 in. (57 mm)
 3 in. (76 mm)
 3-7/8 in. (98 mm)
 4-5/8 in. (117 mm)
 7 in. (178 mm)

Counter Height

Model 245
 44 in. (1118 mm) high
 30 in. (762 mm) wide
 27-3/4 in. (705 mm) deep

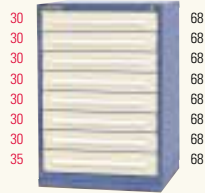

SCU2029AL
 8 Drawers
 160 Compartments
 Usable Drawer Heights
 3-7/8 in. (98 mm)
 4-5/8 in. (117 mm)

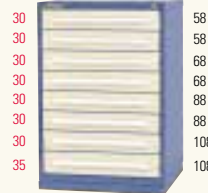

SEP2029AL
 8 Drawers
 144 Compartments
 Usable Drawer Heights
 3-7/8 in. (98 mm)
 4-5/8 in. (117 mm)



SEP2037AL
 8 Drawers
 144 Compartments
 Usable Drawer Heights
 2-1/4 in. (57 mm)
 3 in. (76 mm)
 3-7/8 in. (98 mm)
 8-1/2 in. (216 mm)

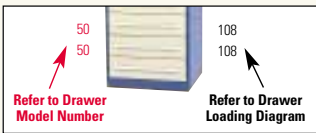

SCU2041AL
 7 Drawers
 140 Compartments
 Usable Drawer Height
 4-5/8 in. (117 mm)

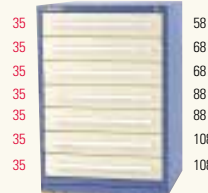

SEP2041AL
 7 Drawers
 120 Compartments
 Usable Drawer Height
 4-5/8 in. (117 mm)

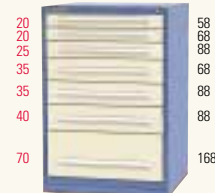

SEP2058AL
 7 Drawers
 120 Compartments
 Usable Drawer Heights
 2-1/4 in. (57 mm)
 3 in. (76 mm)
 4-5/8 in. (117 mm)
 5-3/8 in. (137 mm)
 10-1/8 in. (257 mm)



PRE-CONFIGURED CABINETS

COUNTER HEIGHT



SCU2043AL
7 Drawers
128 Compartments
Usable Drawer Heights
3-7/8 in. (98 mm)
4-5/8 in. (117 mm)
5-3/8 in. (137 mm)



SCU2089AL
7 Drawers
132 Compartments
Usable Drawer Heights
3-7/8 in. (98 mm)
4-5/8 in. (117 mm)
8-1/2 in. (216 mm)

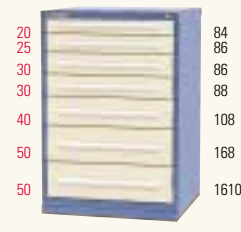

RP2102AL
7 Drawers
114 Compartments
Usable Drawer Heights
2-1/4 in. (57 mm)
3 in. (76 mm)
3-7/8 in. (98 mm)
5-3/8 in. (137 mm)
7 in. (178 mm)

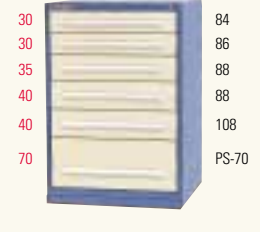

RP2112AL
6 Drawers
98 Compartments
Usable Drawer Heights
3-7/8 in. (98 mm)
4-5/8 in. (117 mm)
5-3/8 in. (137 mm)
10-1/8 in. (257 mm)

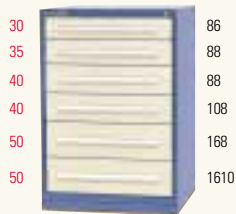

RP2113AL
6 Drawers
78 Compartments
Usable Drawer Heights
3-7/8 in. (98 mm)
4-5/8 in. (117 mm)
5-3/8 in. (137 mm)
7 in. (178 mm)



SCU2066AL
6 Drawers
96 Compartments
Usable Drawer Heights
3-7/8 in. (98 mm)
4-5/8 in. (117 mm)
5-3/8 in. (137 mm)
7 in. (178 mm)

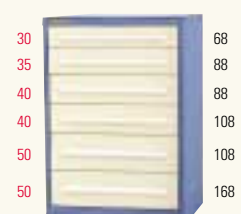

SEP2066AL
6 Drawers
84 Compartments
Usable Drawer Heights
3-7/8 in. (98 mm)
4-5/8 in. (117 mm)
5-3/8 in. (137 mm)
7 in. (178 mm)

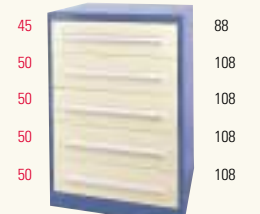

SCU2070AL
5 Drawers
76 Compartments
Usable Drawer Heights
6-1/4 in. (159 mm)
7 in. (178 mm)

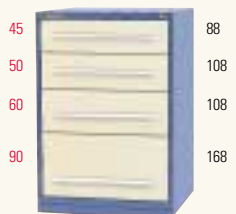

SCU2076AL
4 Drawers
48 Compartments
Usable Drawer Heights
6-1/4 in. (159 mm)
7 in. (178 mm)
8-1/2 in. (216 mm)
13-1/4 in. (337 mm)



SEP2076AL
4 Drawers
44 Compartments
Usable Drawer Heights
6-1/4 in. (159 mm)
7 in. (178 mm)
8-1/2 in. (216 mm)
13-1/4 in. (337 mm)



SCU2079AL
3 Drawers
27 Compartments
Usable Drawer Heights
10-7/8 in. (276 mm)
11-3/4 in. (9318 mm)
13-1/4 in. (337 mm)



SEP2079AL
3 Drawers
17 Compartments
Usable Drawer Heights
10-7/8 in. (276 mm)
11-3/4 in. (9318 mm)
13-1/4 in. (337 mm)



SEP1001AL
7 Drawers
152 Compartments
Usable Drawer Height
3 in. (76 mm)



SEP1002AL
7 Drawers
140 Compartments
Usable Drawer Heights
2-1/4 in. (57 mm)
3-7/8 in. (98 mm)
4-5/8 in. (117 mm)



SEP1004AL
6 Drawers
108 Compartments
Usable Drawer Heights
2-1/4 in. (57 mm)
3 in. (76 mm)
3-7/8 in. (98 mm)
7 in. (178 mm)

Bench and Workstation Height

Model 175

33 in. (838 mm) high
30 in. (762 mm) wide
27-3/4 in. (705 mm) deep



SEP1016AL
5 Drawers
92 Compartments
Usable Drawer Heights
3 in. (76 mm)
3-7/8 in. (98 mm)
6-1/4 in. (159 mm)
7 in. (178 mm)



SCU1004AL
6 Drawers
124 Compartments
Usable Drawer Heights
2-1/4 in. (57 mm)
3 in. (76 mm)
3-7/8 in. (98 mm)
7 in. (178 mm)



SEP1019AL
5 Drawers
84 Compartments
Usable Drawer Heights
2-1/4 in. (57 mm)
5-3/8 in. (137 mm)
6-1/4 in. (159 mm)
7 in. (178 mm)

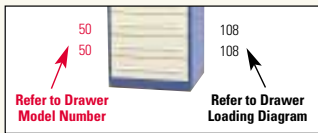

SEP1023AL
5 Drawers
92 Compartments
Usable Drawer Heights
2-1/4 in. (57 mm)
3 in. (76 mm)
3-7/8 in. (98 mm)
5-3/8 in. (137 mm)
8-1/2 in. (216 mm)



SCU1012AL
5 Drawers
92 Compartments
Usable Drawer Heights
3-7/8 in. (98 mm)
5-3/8 in. (137 mm)
6-1/4 in. (159 mm)



SCU1023AL
5 Drawers
96 Compartments
Usable Drawer Heights
2-1/4 in. (57 mm)
3 in. (76 mm)
3-7/8 in. (98 mm)
5-3/8 in. (137 mm)
8-1/2 in. (216 mm)



PRE-CONFIGURED CABINETS

BENCH AND WORKSTATION HEIGHT



SCU1010AL
5 Drawers
100 Compartments
Usable Drawer Height
4-5/8 in. (117 mm)



SEP1031AL
4 Drawers
56 Compartments
Usable Drawer Heights
5-3/8 in. (137 mm)
6-1/4 in. (159 mm)



SCU1043AL
3 Drawers
36 Compartments
Usable Drawer Heights
6-1/4 in. (159 mm)
8-1/2 in. (216 mm)
10-1/8 in. (257 mm)



SCU1072AL
3 Drawers
40 Compartments
Usable Drawer Heights
2-1/4 in. (57 mm)
10-7/8 in. (276 mm)
11-3/4 in. (318 mm)



SEP1045AL
2 Drawers
16 Compartments
Usable Drawer Heights
12-1/2 in. (318 mm)
13-1/4 in. (337 mm)



SD175LH1
Left hinge
SD175RH1
Right hinge
2 Shelves





SCU1904AL
8 Drawers
176 Compartments
Usable Drawer Heights
2-1/4 in. (57 mm)
3-7/8 in. (98 mm)
5-3/8 in. (137 mm)



SCU1905AL
7 Drawers
144 Compartments
Usable Drawer Heights
2-1/4 in. (57 mm)
3-7/8 in. (98 mm)
5-3/8 in. (137 mm)
7 in. (178 mm)



SCU1905AL
7 Drawers
140 Compartments
Usable Drawer Heights
2-1/4 in. (57 mm)
3-7/8 in. (98 mm)
5-3/8 in. (137 mm)
7 in. (178 mm)

Stand-Up Height

Model 200

37 in. (940 mm) high
30 in. (762 mm) wide
27-3/4 in. (705 mm) deep

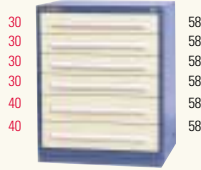

SCU1910AL
6 Drawers
144 Compartments
Usable Drawer Heights
3-7/8 in. (98 mm)
5-3/8 in. (137 mm)



SCU1915AL
5 Drawers
80 Compartments
Usable Drawer Height
5-3/8 in. (137 mm)



SCU1917AL
5 Drawers
84 Compartments
Usable Drawer Heights
2-1/4 in. (57 mm)
3-7/8 in. (98 mm)
5-3/8 in. (137 mm)
7 in. (178 mm)
8-1/2 in. (216 mm)

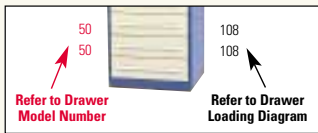

SCU1918AL
5 Drawers
88 Compartments
Usable Drawer Heights
2-1/4 in. (57 mm)
3-7/8 in. (98 mm)
5-3/8 in. (137 mm)
11-3/4 in. (292 mm)



SCU1920AL
4 Drawers
48 Compartments
Usable Drawer Height
7 in. (178 mm)



SCU1927AL
2 Drawers
48 Compartments
Usable Drawer Heights
2-1/4 in. (57 mm)
3 in. (76 mm)

PRE-CONFIGURED CABINETS

DRAWER INTERIORS

Drawer Interiors for Standard Pre-Configured Cabinets

Standard Loading Diagrams

These 28 proven drawer interiors are featured in the standard pre-configured cabinets shown on the previous pages. Factory installation of partitions and dividers is included for all loading diagrams shown in this catalog. If your application requires drawer arrangements other than these call 800-523-9462.

Keep Everything Organized and in Reach

The ability to see a drawer's entire contents in one glance, along with clear labeling and good organization, permits rapid inventory checks and eliminates the possibility of running out of stock without realizing it.



LD3232
1 Compartment
25-1/8 in. x 25-1/8 in.
(638 mm x 638 mm)



LD46
40 Compartments
2-5/8 in. x 4-5/8 in.
(67 mm x 117 mm)



LD510
18 Compartments
3-1/2 in. x 7-7/8 in.
(89 mm x 200 mm)



LD516
12 Compartments
3-1/2 in. x 12-1/2 in.
(89 mm x 318 mm)



LD48
32 Compartments
25/8 in. x 6-1/8 in.
(67 mm x 156 mm)



LD54
48 Compartments
3-1/2 in. x 2-7/8 in.
(89 mm x 73 mm)



LD56
30 Compartments
3-1/2 in. x 4-5/8 in.
(89 mm x 117 mm)



LD58
24 Compartments
3-1/2 in. x 6-1/8 in.
(89 mm x 156 mm)



LD65
30 Compartments
4-1/4 in. x 3-7/8 in.
(108 mm x 98 mm)



LD66
25 Compartments
4-1/4 in. x 4-5/8 in.
(108 mm x 117 mm)



LD68
20 Compartments
4-1/4 in. x 6-1/8 in.
(108 mm x 156 mm)



LD610
15 Compartments
4-1/4 in. x 7-7/8 in.
(108 mm x 200 mm)

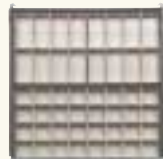

BN-48
48 Bins
(32) 3 in. x 3 in.
(76 mm x 76 mm)
(16) 3 in. x 6-1/8 in.
(76 mm x 156 mm)



LD168
8 Compartments
12-1/4 in. x 6-1/8 in.
(311 mm x 156 mm)



LD86
20 Compartments
5-7/8 in. x 4-5/8 in.
(149 mm x 117 mm)



LD88
16 Compartments
5-7/8 in. x 6-1/8 in.
(149 mm x 156 mm)



LD810
12 Compartments
5-7/8 in. x 7-7/8 in.
(149 mm x 200 mm)



LD816
8 Compartments
5-7/8 in. x 12-1/2 in.
(149 mm x 318 mm)



LD84
32 Compartments
5-7/8 in. x 2-7/8 in.
(149 mm x 73 mm)



LD85
24 Compartments
7-1/2 in. x 3-7/8 in.
(191 mm x 98 mm)



LD1016
6 Compartments
7-1/2 in. x 12-1/2 in.
(191 mm x 318 mm)



LD1610
6 Compartments
12-1/4 in. x 7-7/8 in.
(311 mm x 200 mm)



BN-12 12 Bins:
(4) 6-1/8 in. x 12 in.
(156 mm x 305 mm)
(8) 6-1/8 in. x 6-1/8 in.
(156 mm x 156 mm)



BN-16 16 Bins:
(16) 6-1/8 in. x 6-1/8 in.
(156 mm x 156 mm)



LD108
12 Compartments
7-1/2 in. x 6-1/8 in.
(191 mm x 156 mm)



LD1010
9 Compartments
7-1/2 in. x 7-7/8 in.
(191 mm x 200 mm)



BN-24 24 Bins:
(8) 6-1/8 in. x 6-1/8 in.
(156 mm x 156 mm)
(16) 3 in. x 6-1/8 in.
(76 mm x 156 mm)



BN-32 32 Bins:
(32) 3 in. x 6-1/8 in.
(76 mm x 156 mm)

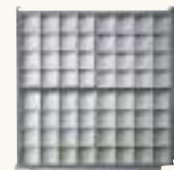

BN-64 64 Bins:
(64) 3 in. x 3 in.
(76 mm x 76 mm)



PS70
2 Hanging File
Compartments
12-1/4 in. x 25-1/8 in.
(311 mm x 638 mm)

Toll Free Customer Service Number: 1-800-523-9462
Customer Service FAX Number: 1-800-523-9934

PRE-CONFIGURED CABINETS

SHALLOW DEPTH

Drawer Interiors for Shallow Depth Pre-Configured Cabinets

Shallow Depth Loading Diagrams

An "L" suffix added to the end of a loading diagram model number indicates that the partitions run left to right.



LDLW46
32 Compartments
2-5/8 in. x 4-1/2 in.
(67 mm x 114 mm)



LDLW56
24 Compartments
3-1/2 in. x 4-1/2 in.
(89 mm x 114 mm)



LDLW58
18 Compartments
3-1/2 in. x 6-1/8 in.
(89 mm x 156 mm)



LDLW512
12 Compartments
3-1/2 in. x 9-1/4 in.
(89 mm x 235 mm)



LDLW64
30 Compartments
4-1/2 in. x 2-7/8 in.
(114 mm x 73 mm)



LDLW66
20 Compartments
4-1/4 in. x 4-1/2 in.
(108 mm x 114 mm)



LDLW68
15 Compartments
4-1/4 in. x 6-1/8 in.
(108 mm x 156 mm)



LDLW612
10 Compartments
4-1/4 in. x 9-1/4 in.
(108 mm x 235 mm)



LDLW84
24 Compartments
5-7/8 in. x 2-7/8 in.
(149 mm x 73 mm)



LDLW86
16 Compartments
5-7/8 in. x 4-1/2 in.
(149 mm x 114 mm)



LDLW88
12 Compartments
5-7/8 in. x 6-1/8 in.
(149 mm x 156 mm)



LDLW812
8 Compartments
5-7/8 in. x 9-1/4 in.
(149 mm x 235 mm)



LDLW106
12 Compartments
7-1/2 in. x 4-1/2 in.
(191 mm x 114 mm)



LDLW108
9 Compartments
7-1/2 in. x 6-1/8 in.
(191 mm x 156 mm)



LDLW1012
6 Compartments
7-1/2 in. x 9-1/4 in.
(191 mm x 235 mm)



LDLW166
8 Compartments
12-1/2 in. x 4-1/2 in.
(318 mm x 114 mm)



LDLW168
6 Compartments
12-1/2 in. x 6-1/8 in.
(318 mm x 156 mm)



LDLW1612
4 Compartments
12-1/2 in. x 9-1/4 in.
(318 mm x 235 mm)



LDLW68L
16 Compartments
4-1/4 in. x 6-1/8 in.
(108 mm x 156 mm)



LDLW84L
24 Compartments
5-7/8 in. x 2-7/8 in.
(149 mm x 73 mm)



LDLW88L
12 Compartments
5-7/8 in. x 6-1/8 in.
(149 mm x 156 mm)

Toll Free Customer Service Number: 1-800-523-9462
Customer Service FAX Number: 1-800-523-9934



RP1135AL
33 in. (838 mm) High
Usable Drawer Height
3 in. (76 mm)

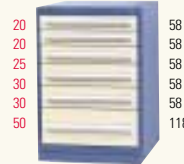

RP1134AL
633 in. (838 mm) High
6 Drawers
88 Compartments
Usable Drawer Heights
2-1/4 in. (57 mm)
3 in. (76 mm)
3-7/8 in. (98 mm)
7 in. (178 mm)

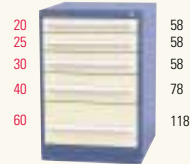

RP1136AL
33 in. (838 mm) High
5 Drawers
68 Compartments
Usable Drawer Heights
2-1/4 in. (57 mm)
3 in. (76 mm)
3-7/8 in. (98 mm)
5-3/8 in. (137 mm)
8-1/2 in. (216 mm)

Small Version

22-1/2 in. (572 mm) wide
27-3/4 in. (705 mm) deep
Available in all standard heights.

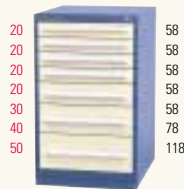

RP1940AL
37 in. (940 mm) High
7 Drawers
100 Compartments
Usable Drawer Heights
2-1/4 in. (57 mm)
3-7/8 in. (98 mm)
5-3/8 in. (137 mm)
7 in. (178 mm)

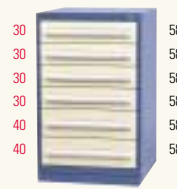

RP1939AL
37 in. (940 mm) High
6 Drawers
96 Compartments
Usable Drawer Heights
3-7/8 in. (98 mm)
5-3/8 in. (137 mm)

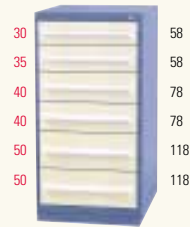

RP2143AL
44 in. (1118 mm) High
6 Drawers
72 Compartments
Usable Drawer Heights
3-7/8 in. (98 mm)
4-5/8 in. (117 mm)
5-3/8 in. (137 mm)
7 in. (178 mm)

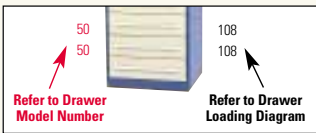

RP3501AL
59 in. (1499 mm) High
9 Drawers
120 Compartments
Usable Drawer Heights
3-7/8 in. (98 mm)
5-3/8 in. (137 mm)
8-1/2 in. (216 mm)

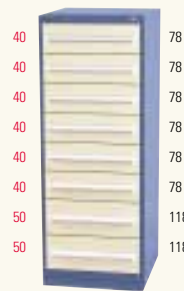

RP3500AL
59 in. (1499 mm) High
8 Drawers
88 Compartments
Usable Drawer Heights
5-3/8 in. (137 mm)
7 in. (178 mm)

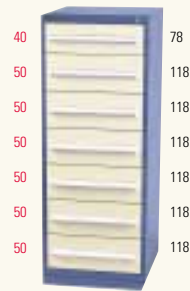

RP3502AL
59 in. (1499 mm) High
7 Drawers
60 Compartments
Usable Drawer Heights
5-3/8 in. (137 mm)
7 in. (178 mm)

PRE-CONFIGURED CABINETS

SMALL VERSION

Drawer Interiors for Small Version Pre-Configured Cabinets

Small Version Loading Diagrams



LDSV54
32 Compartments
3-1/2 in. x 2-7/8 in.
(89 mm x 73 mm)



LDSV56
20 Compartments
3-1/2 in. x 4-5/8 in.
(89 mm x 117 mm)



LDSV58
16 Compartments
3-1/2 in. x 6-1/8 in.
(89 mm x 156 mm)



LDSV510
12 Compartments
3-1/2 in. x 7-7/8 in.
(89 mm x 200 mm)



LDSV532
4 Compartments
3 1/2 in. x 25 1/8 in.
(89 mm x 638 mm)



LDSV74
24 Compartments
5-1/8 in. x 2-7/8 in.
(130 mm x 73 mm)



LDSV76
15 Compartments
5-1/8 in. x 4-5/8 in.
(130 mm x 117 mm)



LDSV78
12 Compartments
5-1/8 in. x 6-1/8 in.
(130 mm x 156 mm)



LDSV710
9 Compartments
5-1/8 in. x 7-7/8 in.
(130 mm x 200 mm)



LDSV732
3 Compartments
5-1/8 in. x 25-1/8 in.
(130 mm x 638 mm)



LDSV114
16 Compartments
8-1/4 in. x 2-7/8 in.
(210 mm x 73 mm)



LDSV116
10 Compartments
8-1/4 in. x 4-5/8 in.
(210 mm x 117 mm)



LDSV118
8 Compartments
8-1/4 in. x 6-1/8 in.
(210 mm x 156 mm)



LDSV1116
4 Compartments
8-1/4 in. x 12-1/2 in.
(210 mm x 318 mm)



LDSV1132
2 Compartments
8-1/4 in. x 25-1/8 in.
(210 mm x 638 mm)

Toll Free Customer Service Number: 1-800-523-9462
Customer Service FAX Number: 1-800-523-9934



RP1147AL
 33 in. (838 mm) High
 6 Drawers
 204 Compartments
 Usable Drawer Heights
 2-1/4 in. (57 mm)
 3 in. (76 mm)
 3-7/8 in. (98 mm)
 7 in. (178 mm)



RP1146AL
 33 in. (838 mm) High
 5 Drawers
 156 Compartments
 Usable Drawer Heights
 2-1/4 in. (57 mm)
 3 in. (76 mm)
 3-7/8 in. (98 mm)
 5-3/8 in. (137 mm)
 8-1/2 in. (216 mm)



RP1943AL
 37 in. (940 mm) High
 2 Drawers
 1 Bottom Pan
 64 Compartments
 Usable Drawer Heights
 3-7/8 in. (98 mm)
 4-5/8 in. (117 mm)

Extra wide

45 in. (1143 mm) wide
 27-3/4 in. (705 mm) deep
 Available in all standard heights.



RP2147AL
 44 in. (1118 mm) High
 6 Drawers
 152 Compartments
 Usable Drawer Heights
 3-7/8 in. (98 mm)
 4-5/8 in. (117 mm)
 5-3/8 in. (137 mm)
 7 in. (178 mm)



RP2146AL
 44 in. (1118 mm) High
 5 Drawers
 140 Compartments
 Usable Drawer Heights
 3 in. (76 mm)
 5-3/8 in. (137 mm)
 7 in. (178 mm)
 11-3/4 in. (292 mm)



RP3505AL
 59 in. (1499 mm) High
 11 Drawers
 371 Compartments
 Usable Drawer Heights
 2-1/4 in. (57 mm)
 3-7/8 in. (98 mm)
 5-3/8 in. (137 mm)
 7 in. (178 mm)

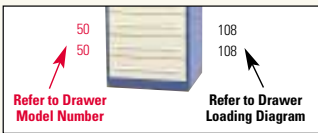

RP3506AL
 59 in. (1499 mm) High
 9 Drawers
 244 Compartments
 Usable Drawer Heights
 3-7/8 in. (98 mm)
 5-3/8 in. (137 mm)
 8-1/2 in. (216 mm)



RP3507AL
 59 in. (1499 mm) High
 4 Drawers
 1 Roll out Shelf
 8 Compartments
 Usable Drawer Heights
 2-1/4 in. (57 mm)
 11-3/4 in. (292 mm)

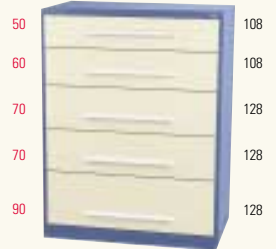

RP3508AL
 59 in. (1499 mm) High
 5 Drawers
 88 Compartments
 Usable Drawer Heights
 7 in. (178 mm)
 8-1/2 in. (216 mm)
 10-1/8 in. (257 mm)
 13-1/4 in. (337 mm)



PRE-CONFIGURED CABINETS

EXTRA WIDE

Drawer Interiors for Extra Wide Pre-Configured Cabinets

Extra Wide Loading Diagrams

An "L" suffix added to the end of a loading diagram model number indicates that the partitions run left to right.



LDXW46
60 Compartments
2-5/8 in. x 4-5/8 in.
(67 mm x 117 mm)



LDXW48
48 Compartments
2-5/8 in. x 6-1/8 in.
(67 mm x 156 mm)



LDXWPS70
3 Hanging File Compartments
12-1/4 in. 18-3/4 in.
(311 mm x 476 mm)



LDXW58
40 Compartments
3-1/2 in. x 6-1/8 in.
(89 mm x 156 mm)



LDXW68
32 Compartments
4-1/4 in. x 6-1/8 in.
(108 mm x 156 mm)



LDXW128
16 Compartments
9 in. x 6-1/8 in.
(228 mm x 156 mm)



LDXW84
48 Compartments
5-7/8 in. x 2-7/8 in.
(149 mm x 73 mm)



LDXW88
24 Compartments
5-7/8 in. x 6-1/8 in.
(149 mm x 156 mm)



LDXW816
12 Compartments
5-7/8 in. x 12-1/2 in.
(149 mm x 318 mm)



LDXW108
20 Compartments
7-1/2 in. x 6-1/8 in.
(191 mm x 156 mm)



LDXW1010
15 Compartments
7-1/2 in. x 7-7/8 in.
(191 mm x 200 mm)



LDXW1016
10 Compartments
7-1/2 in. x 12-1/2 in.
(191 mm x 318 mm)

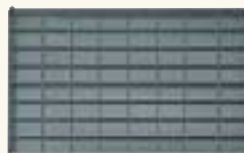

LDXW46L
64 Compartments
2-5/8 in. x 4-5/8 in.
(67 mm x 117 mm)



LDXW451L
8 Compartments
2-5/8 in. x 40-1/4 in.
(67 mm x 1022 mm)



LDXW48L
48 Compartments
2-5/8 in. x 6-1/4 in.
(67 mm x 159 mm)



LDXW551L
6 Compartments
3-1/2 in. x 40-1/4 in.
(89 mm x 1022 mm)



LDXW58L
36 Compartments
3-1/2 in. x 6-1/4 in.
(89 mm x 159 mm)



LDXW651L
5 Compartments
4-1/4 in. x 40-1/4 in.
(108 mm x 1022 mm)



LDXW68L
30 Compartments
4-1/4 in. x 40-1/4 in.
(108 mm x 159 mm)



LDXW84L
48 Compartments
5-7/8 in. x 3 in.
(149 mm x 76 mm)



LDXW851L
4 Compartments
5-7/8 in. x 40-1/4 in.
(149 mm x 1022 mm)



LDXW88L
24 Compartments
5-7/8 in. x 6-1/4 in.
(149 mm x 159 mm)



LDXW1010L
15 Compartments
7-1/2 in. x 7-5/8 in.
(191 mm x 194 mm)



LDXW1051L
3 Compartments
7-1/2 in. x 40-1/4 in.
(191 mm x 1022 mm)



LDXW108L
18 Compartments
7-1/2 in. x 6-1/4 in.
(191 mm x 159 mm)



LDXW1651L
2 Compartments
12-1/2 in. x 40-1/4 in.
(318 mm x 1022 mm)

Toll Free Customer Service Number: 1-800-523-9462
Customer Service FAX Number: 1-800-523-9934



20
20
25
30
30
50



58 20
58 25
58 30
68 40
68 60
108

RP1148AL
33 in. (838 mm) High
6 Drawers
284 Compartments
Usable Drawer Heights
2-1/4 in. (57 mm)
3 in. (76 mm)
3-7/8 in. (98 mm)
7 in. (178 mm)



58 20
58 20
68 30
78 30
108 40
108 60

RP1149AL
33 in. (838 mm) High
5 Drawers
224 Compartments
Usable Drawer Heights
2-1/4 in. (57 mm)
3 in. (76 mm)
3-7/8 in. (98 mm)
5-3/8 in. (137 mm)
8-1/2 in. (216 mm)



58 20
58 20
68 30
68 30
78 40
108

RP1944AL
37 in. (940 mm) High
6 Drawers
268 Compartments
Usable Drawer Heights
2-1/4 in. (57 mm)
3-7/8 in. (98 mm)
5-3/8 in. (137 mm)
8-1/2 in. (216 mm)

Double Wide

60 in. (1524 mm) wide
27-3/4 in. (705 mm) deep
Available in all standard heights.

30
35
40
40
50
50



68 20
68 20
78 20
78 20
108 20
108 20
108 25

RP2148AL
44 in. (1118 mm) High
6 Drawers
224 Compartments
Usable Drawer Heights
3-7/8 in. (98 mm)
4-5/8 in. (117 mm)
5-3/8 in. (137 mm)
7 in. (178 mm)



1670LDWFB06
30
30
30
30
40
40
40
40
40
60
1670LDWFB06

RP2149AL
44 in. (1118 mm) High
7 Drawers
24 Compartments
Usable Drawer Heights
2-1/4 in. (57 mm)
3 in. (76 mm)



68
68
68
68
78
78
78
78
78
108

RP3511AL
59 in. (1499 mm) High
9 Drawers
364 Compartments
Usable Drawer Heights
3-7/8 in. (98 mm)
5-3/8 in. (137 mm)
8-1/2 in. (216 mm)



50
60
70
70
90



108 40
108 50
1416 50
1416 50
1416 50
1416 50

RP3510AL
59 in. (1499 mm) High
5 Drawers
86 Compartments
Usable Drawer Heights
7 in. (178 mm)
8-1/2 in. (216 mm)
10-1/8 in. (257 mm)
13-1/4 in. (337 mm)



78 45
108 45
108 50
108 60
108 60
108 80
108

RP3512AL
59 in. (1499 mm) High
7 Drawers
208 Compartments
Usable Drawer Heights
5-3/8 in. (137 mm)
7 in. (178 mm)



78
108
108
108
108
1416
1416

RP3509AL
59 in. (1499 mm) High
6 Drawers
144 Compartments
Usable Drawer Heights
6-1/4 in. (159 mm)
7 in. (178 mm)
8-1/2 in. (216 mm)
11-3/4 in. (292 mm)



PRE-CONFIGURED CABINETS

DOUBLE WIDE

Drawer Interiors for Double Wide Pre-Configured Cabinets

Double Wide Loading Diagrams

An "L" suffix added to the end of a loading diagram model number indicates that the partitions run left to right.



LDDW58
56 Compartments
3-1/2 in. x 6-1/8 in.
(89 mm x 156 mm)



LDDW68
44 Compartments
4-1/4 in. x 6-1/8 in.
(108 mm x 156 mm)



LDDW78
40 Compartments
5-1/8 in. x 6-1/8 in.
(130 mm x 156 mm)



LDDW108
28 Compartments
7-1/2 in. x 6-1/8 in.
(191 mm x 156 mm)



LDDW470L
8 Compartments
2-5/8 in. x 55-3/8 in.
(67 mm x 1407 mm)



LDDW570L
6 Compartments
3-1/2 in. x 55-3/8 in.
(89 mm x 1047 mm)



LDDW670L
5 Compartments
4-1/4 in. x 55-3/8 in.
(108 mm x 1047 mm)



LDDW870L
4 Compartments
5-7/8 in. x 55-3/8 in.
(149 mm x 1047 mm)



LDDW1070L
3 Compartments
7-1/2 in. x 55-3/8 in.
(191 mm x 1047 mm)



LDDW1670L
2 Compartments
12-1/4 in. x 55-3/8 in.
(311 mm x 1047 mm)



Extra Wide Shallow Depth

45 in. (1143 mm) wide
21-3/8 in. (543 mm) deep



RP3520AL
59 in. (1499 mm) High
9 Drawers
183 Compartments
Usable Drawer Heights
3-7/8 in. (98 mm)
5-3/8 in. (137 mm)
8-1/2 in. (216 mm)



RP3521AL
59 in. (1499 mm) High
5 Drawers
66 Compartments
Usable Drawer Heights
7 in. (178 mm)
8-1/2 in. (216 mm)
10-1/8 in. (257 mm)
13-1/4 in. (337 mm)



RP2151AL
44 in. (1118 mm) High
6 Drawers
114 Compartments
Usable Drawer Heights
3-7/8 in. (98 mm)
4-5/8 in. (117 mm)
5-3/8 in. (137 mm)
7 in. (178 mm)



RP1171AL
33 in. (838 mm) High
6 Drawers
153 Compartments
Usable Drawer Heights
2-1/4 in. (57 mm)
3 in. (76 mm)
3-7/8 in. (98 mm)
7 in. (178 mm)

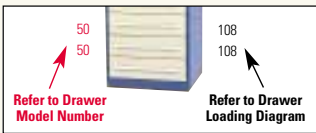

PRE-CONFIGURED CABINETS

EXTRA WIDE SHALLOW DEPTH

Drawer Interiors for Extra Wide Shallow Depth Cabinets

Extra Wide Shallow Depth Loading Diagrams



LDXL58
30 Compartments
(27) 3-1/2 in. x 6-1/8 in.
(89 mm x 156 mm)
(3) 4-1/4 in. x 6-1/8 in.
(108 mm x 156 mm)



LDXL68
24 Compartments
4-1/4 in. x 6-1/8 in.
(108 mm x 156 mm)



LDXL88
18 Compartments
5-7/8 in. x 6-1/8 in.
(149 mm x 156 mm)



LDXL108
15 Compartments
7-1/2 in. x 6-1/8 in.
(191 mm x 156 mm)



LDXL128
12 Compartments
9 in. x 4-5/8 in.
(229 mm x 118 mm)



Toll Free Customer Service Number: 1-800-523-9462
Customer Service FAX Number: 1-800-523-9934

TOOL STORAGE AND SHELF CABINETS

Shelf Cabinets

Stanley® Vidmar® shelf cabinets are used to store bulk material, i.e., gloves, cloths, rags, boxes. They are available with or without doors. All shelf cabinets with doors are equipped with a magnetic catch; locks are also available. The cabinets are of the same modular dimensions and design as standard drawer cabinets, have the same integral pallet base, and will fit perfectly above, alongside or between other Stanley® Vidmar® cabinets. They can also be converted to drawer-cabinet use at any time. Shelf cabinets can provide valuable additional storage to drawer cabinets in various sizes.

135/155/175/200

These sizes are best utilized as desk or workstation cabinets supporting a work surface. In addition, when stacked above 340 cabinets, overflow and semi-bulk inventory can be kept together with drawer inventory in one location instead of two. This also allows larger items in a "parts family" to be kept at the same location as the smaller items.

245

The 44 in. height of these shelf cabinets is ideal for issue counter use. A shelf cabinet can provide badly needed space for at-hand items like catalogs, binders, and quick-issue items.

340

59 in. cabinets provide often needed shelf space in a drawer cabinet installation.

Shelves

Shelves for these cabinets (adjustable in increments of approximately 3/4 in.) must be ordered separately. No tools are required for shelf installation.

Shelf Door Locks

For security, shelf door cabinet locks are available.



(Shown with door and bottom pan.)

Shelves

MODEL#	SIZE	WEIGHT CAPACITY
CS40	25-1/4 in. x 27-1/4 in.	400 lbs. (181 kg)
CS80	25-1/4 in. x 27-1/4 in.	800 lbs. (363 kg)

*For lip feature, add suffix "L" to Model#
For shelves other than standard cabinets, add the appropriate prefix XW, DW, SV, or LW.

Shelf Door Locks

MODEL#	FOR USE WITH
SDL3401	340 Shelf Door Cabinet
SDL2451	245 Shelf Door Cabinet
SDL2001	200 Shelf Door Cabinet
SDL1751	175 Shelf Door Cabinet
SDL1551	155 Shelf Door Cabinet
SDL1351	135 Shelf Door Cabinet

Shelf Cabinet (without door)

MODEL#	STANDARD HOUSING			MODEL#	EXTRA WIDE			MODEL#	DOUBLE WIDE			MODEL#	SMALL VERSION			MODEL#	SHALLOW DEPTH		
	W IN.	D IN.	H IN.		W IN.	D IN.	H IN.		W IN.	D IN.	H IN.		W IN.	D IN.	H IN.		W IN.	D IN.	H IN.
S0135	30	27-3/4	27	XWS0135	45	27-3/4	27	DWS0135	60	27-3/4	27	SVS0135	22-1/2	27-3/4	27	LWS0135	30	21-3/8	27
S0155	30	27-3/4	30	XWS0155	45	27-3/4	30	DWS0155	60	27-3/4	30	SVS0155	22-1/2	27-3/4	30	LWS0155	30	21-3/8	30
S0175	30	27-3/4	33	XWS0175	45	27-3/4	33	DWS0175	60	27-3/4	33	SVS0175	22-1/2	27-3/4	33	LWS0175	30	21-3/8	33
S0200	30	27-3/4	37	XWS0200	45	27-3/4	37	DWS0200	60	27-3/4	37	SVS0200	22-1/2	27-3/4	37	LWS0200	30	21-3/8	37
S0245	30	27-3/4	44	XWS0245	45	27-3/4	44	DWS0245	60	27-3/4	44	SVS0245	22-1/2	27-3/4	44	LWS0245	30	21-3/8	44
S0340	30	27-3/4	59	XWS0340	45	27-3/4	59	DWS0340	60	27-3/4	59	SVS0340	22-1/2	27-3/4	59	LWS0340	30	21-3/8	59

If only a door assembly is required, model numbers become; Example: SDD135 RH

Shelf Door Cabinet*

MODEL#	STANDARD HOUSING			MODEL#	EXTRA WIDE			MODEL#	DOUBLE WIDE			MODEL#	SMALL VERSION			MODEL#	SHALLOW DEPTH		
	W IN.	D IN.	H IN.		W IN.	D IN.	H IN.		W IN.	D IN.	H IN.		W IN.	D IN.	H IN.		W IN.	D IN.	H IN.
SD0135	30	27-3/4	27	XWSD0135	45	27-3/4	27	DWSD0135	60	27-3/4	27	SVSD0135	22-1/2	27-3/4	27	LWSD0135	30	21-3/8	27
SD0155	30	27-3/4	30	XWSD0155	45	27-3/4	30	DWSD0155	60	27-3/4	30	SVSD0155	22-1/2	27-3/4	30	LWSD0155	30	21-3/8	30
SD0175	30	27-3/4	33	XWSD0175	45	27-3/4	33	DWSD0175	60	27-3/4	33	SVSD0175	22-1/2	27-3/4	33	LWSD0175	30	21-3/8	33
SD0200	30	27-3/4	37	XWSD0200	45	27-3/4	37	DWSD0200	60	27-3/4	37	SVSD0200	22-1/2	27-3/4	37	LWSD0200	30	21-3/8	37
SD0245	30	27-3/4	44	XWSD0245	45	27-3/4	44	DWSD0245	60	27-3/4	44	SVSD0245	22-1/2	27-3/4	44	LWSD0245	30	21-3/8	44
SD0340	30	27-3/4	59	XWSD0340	45	27-3/4	59	DWSD0340	60	27-3/4	59	SVSD0340	22-1/2	27-3/4	59	LWSD0340	30	21-3/8	59

*Specify right hand or left hand hinged door.

Toll Free Customer Service Number: 1-800-523-9462
Customer Service FAX Number: 1-800-523-9934

Safety Cabinets

Stanley® Vidmar® Safety Cabinets are the simple, efficient solution to on-site storage of hazardous or dangerous liquids and materials. Cabinets are available for flammables, acids and corrosives, and paint and ink storage. Their bright HazMat based colors immediately identify them and their contents.

Every Stanley® Vidmar® Safety Cabinet is constructed of 18 gauge steel with double walls on top, sides, bottom and doors. All double walls integrate a 1-1/2 in. (38 mm) air space for added safety. All cabinets are equipped with two side vents, both with 2 in. (51 mm) threaded fittings, fire baffle and cap. All Stanley® Vidmar® Safety Cabinets are supplied with high-gloss, epoxy powder coatings inside and out for better protection against spills or splashes.

Acid/Corrosive Cabinet Models

Acid and Corrosive Storage Cabinets are ideal for use in storing small containers of up to 5 gal (19 L) of flammable and non-flammable acids and corrosive liquids. All surfaces are coated with blue, epoxy powder coating for superior protection against chemical spills or splashes. All cabinets are provided with high-density polyethylene shelf trays and cabinet bottom for all 30 gal (114 L) and 45 gal (170 L) cabinets.

Paint/Ink Cabinet Models

Paint and Ink Storage Cabinets safely store printing inks and other paint products. All Paint and Ink Storage Cabinets have a red, high-gloss, epoxy powder finish.

Flammable Cabinet Models

Flammable Cabinets keep required flammable liquids near work areas, and include grounding attachment. High-gloss, HazMat yellow finish. Meet OSHA requirements, meet NFPA Code 30 requirements, and meet FM approval.

Accessories

Additional shelves, polyethylene trays, and self closing kits can be added to any Stanley® Vidmar® Safety Cabinet from the list.



Acid/Corrosives Cabinet Models

DOOR SPECS	MODEL#*	CAPACITY	APPROVAL	WIDTH	DEPTH	HEIGHT	SHELF DEPTH	SHELVES	TRAYS	BTM TRAYS	WEIGHT
2 Doors	CAC30M	30 gal (114 L)	FM	43 in. (1092 mm)	18 in. (457 mm)	44 in. (1118 mm)	14-3/4 in. (375 mm)	1	1	1	253 lbs (115 kg)
2 Doors	CAC45M	45 gal (170 L)	FM	43 in. (1092 mm)	18 in. (457 mm)	65 in. (1651 mm)	14-3/4 in. (375 mm)	2	2	1	351 lbs (159 kg)
2 Doors	CAC60M	60 gal (227 L)	FM	31-1/4 in. (794 mm)	31-1/4 in. (794 mm)	65 in. (1651 mm)	28 in. (711 mm)	2	2	1	363 lbs (165 kg)

*M — Manual Doors
Weight Includes Packaging

Paint/Ink Cabinet Models

DOOR SPECS	MODEL#*	CAPACITY	APPROVAL	WIDTH	DEPTH	HEIGHT	SHELF DEPTH	SHELVES	WEIGHT
2 Doors	PIC40M	40 gal (151 L)	FM	43 in. (1092 mm)	18 in. (457 mm)	44 in. (1118 mm)	14-3/4 in. (375 mm)	3	272 lbs (123 kg)
2 Doors	PIC60M	60 gal (227 L)	FM	43 in. (1092 mm)	18 in. (457 mm)	65 in. (1651 mm)	14-3/4 in. (375 mm)	5	380 lbs (172 kg)

Weight Includes Packaging

Flammables Cabinet Models

DOOR SPECS	MODEL#*	CAPACITY	APPROVAL	WIDTH	DEPTH	HEIGHT	SHELF DEPTH	SHELVES	WEIGHT
2 Doors	FLC30M	30 gal (114 L)	FM	43 in. (1092 mm)	18 in. (457 mm)	44 in. (1118 mm)	14-3/4 in. (375 mm)	1	247 lbs (112 kg)
2 Doors	FLC30SC	30 gal (114 L)	FM	43 in. (1092 mm)	18 in. (457 mm)	44 in. (1118 mm)	14-3/4 in. (375 mm)	1	257 lbs (117 kg)
Doors	FLC45M	45 gal (170 L)	FM	43 in. (1092 mm)	18 in. (457 mm)	65 in. (1651 mm)	14-3/4 in. (375 mm)	2	342 lbs (155 kg)
2 Doors	FLC45SC	45 gal (170 L)	FM	43 in. (1092 mm)	18 in. (457 mm)	65 in. (1651 mm)	14-3/4 in. (375 mm)	2	353 lbs (160 kg)
2 Doors	FLC60M	60 gal (227 L)	FM	31-1/4 in. (794 mm)	31-1/4 in. (794 mm)	65 in. (1651 mm)	28 in. (711 mm)	2	354 lbs (161 kg)
2 Doors	FLC60SC	60 gal (227 L)	FM	31-1/4 in. (794 mm)	31-1/4 in. (794 mm)	65 in. (1651 mm)	28 in. (711 mm)	2	364 lbs (165 kg)

*M — Manual Doors
Weight Includes Packaging

Accessories

TYPE	MODEL#	DESCRIPTION
Epoxy Coated Metal Shelf	CAS-XX	Specify capacity of 30, 45, or 60 gal (114, 170, or 227 L)*
Metal Shelf	FLS-XX	Specify capacity of 30, 45, or 60 gal (114, 170, or 227 L)*
Metal Shelf	PIS-XX	Specify capacity of 40 or 60 gal (151 or 227 L)*
Poly. Bottom Tray	CAPBT-XX	Specify capacity of 30, 45, or 60 gal (114, 170, or 227 L)*
Poly. Shelf Tray	CAPST-XX	Specify capacity of 30, 45, or 60 gal (114, 170, or 227 L)*
Adaptor Kits	FLAK	All Flammable
Adaptor Kits	CAAK	All Acid/Corrosive
Adaptor Kits	PIAK	All Paint/Ink

*For "XX"

SAFETY AND COMPUTER CABINETS

Personal Computer Cabinet

For PCs on the shop floor. Consists of Standard 340 housing mounted on an 8 in. (203 mm) base, with hinged upper door with viewing window, fold-away keyboard drawer, ventilating fan, roll-out printer shelf, six-outlet power strip, and double lower doors with lock. 30 in. W x 27-3/4 in. D x 65 in. H (762 mm W x 711 mm D x 1651 mm H).

Computer Cabinet

MODEL#	DESCRIPTION
PCC0340A	With Stationary base
PCM0340A	With mobile base — 6 in. (152 mm) wheels
MPT	Mouse pad tray



Custom Cabinets

Custom designed based on your specific needs. The custom cabinet section lists the various components that can be used to custom build a cabinet using one of eight cabinet housings. The following information will walk you through how to build a custom cabinet. Custom cabinets are built to order. You choose what you want, from the housing height to the drawers, roll-out or stationary shelves, and shelf cabinet doors. You decide what best fits your needs and in what combination. Contact your Stanley® Vidmar® Customer Service Representative with any additional questions you may have concerning Stanley® Vidmar® Custom Cabinets at 800-523-9462.







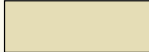

1. Housing

Each custom cabinet starts with one of eight cabinet housing footprints. The height for each of the above custom cabinet housings listed in the catalog ranges from 27-59 in. Each height receives a model number:

- 27 in. high - Model 135
- 30 in. high - Model 155
- 33 in. high - Model 175
- 37 in. high - Model 200
- 44 in. high - Model 245
- 59 in. high - Model 340

So if you need a Standard cabinet that is 59 in. high, the model number for the cabinet would be Standard cabinet Model 340.

Cabinets are available in ten standard colors.

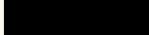
	Off White S22570
	Beige S20100
	Vidmar Green S20606
	Hunter Green S50091
	Light Blue S22577
	Bright Blue S22447
	Dark Blue S22578
	Red S50054
	Vidmar Gray S23321
	Black S20106

1.



Standard
30 in. W x 27-3/4 in. D
(762 mm W x 705 mm D)



Shallow Depth
30 in. W x 21-3/8 in. D
(762 mm W x 543 mm D)



Small Version
22-1/2 in. W x 27-3/4 in. D
(572 mm W x 705 mm D)



Small Version Shallow Depth
22-1/2 in. W x 21-3/8 in. D
(572 mm W x 543 mm D)



Extra Wide
45 in. W x 27-3/4 in. D
(1143 mm W x 705 mm D)



Extra Wide Shallow Depth
45 in. W x 21-3/8 in. D
(1143 mm W x 543 mm D)



Double Wide
60 in. W x 27-3/4 in. D
(1524 mm W x 705 mm D)



Double Wide Shallow Depth
60 in. W x 21-3/8 in. D
(1524 mm W x 543 mm D)

HOW TO BUILD A CUSTOM CABINET

CABINET FEATURES

2. Drawers

Now you're ready to add drawers to your cabinet. Like the model number given to each of the above housing heights, the drawers also have model numbers ranging from Model 20 to Model 90. Each drawer model number represents a different drawer height. For additional drawer heights contact your Stanley® Vidmar® Customer Service Representative at 800-523-9462.

When trying to determine how many drawers will fit in your housing, add up all the drawer model numbers you have chosen for your cabinet. The drawer model numbers are shown on the left side of each cabinet in red. The sum total of all the drawer model numbers must equal the cabinet height model number.

Thus, if you have a Standard Version cabinet Model 340 (59 in. high) with the below seven drawer model numbers, the sum total of those drawer model numbers should equal the 340 Model number used for the height of the cabinet. If the total sum of the drawer model numbers do not equal the cabinet height model numbers, then the drawers will not fit in the cabinet housing. Drawers and roll-out shelves can be used in combination when building a cabinet.

Drawer Model Numbers	Useable Height
40	(5-3/8 in.)
50	(7 in.)
50	(7 in.)
50	(7 in.)
50	(7 in.)
50	(7 in.)
+50	(7 in.)

Standard cabinet Model 340

3. Partitions and Dividers

The partition and divider setup used to build compartments in each drawer is referred to as a "Loading Diagram". Each Loading Diagram has its own model number. Some of the most popular Loading Diagrams for each of the housings listed above are shown on pages 11, 17 and 19. You can choose among these Loading Diagrams to specify how many partitions and dividers you need per drawer in order to create the storage compartments you require. Additional Loading Diagrams are available by contacting your Stanley® Vidmar® Customer Service Representative at 800-523-9462.



2.

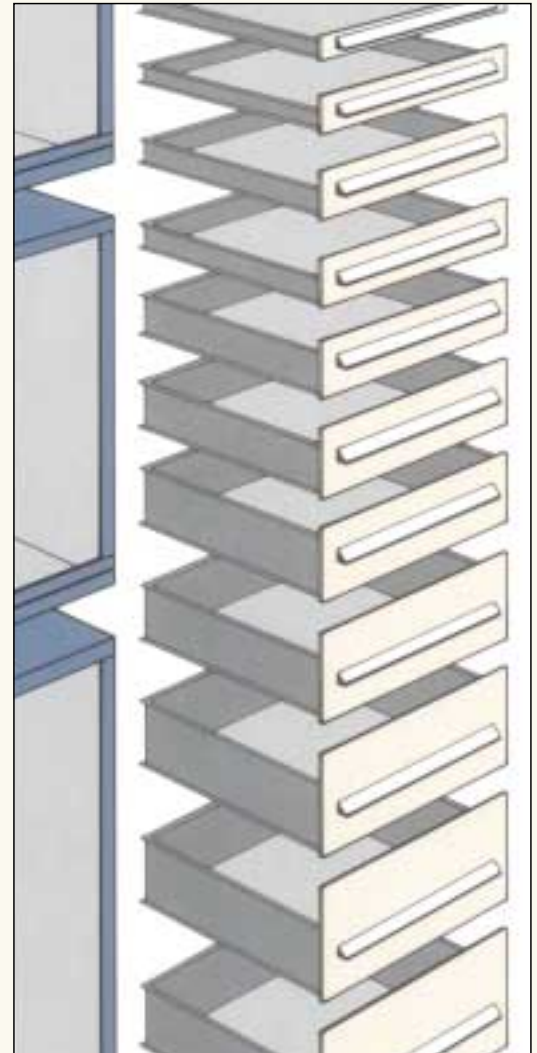
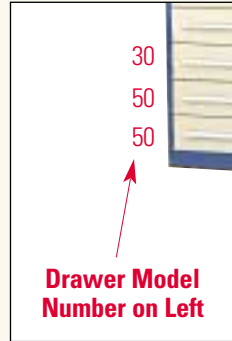

3.

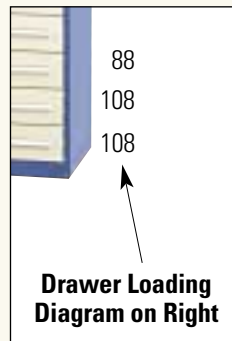

4. Roll-Out Shelves

A roll-out shelf is traditionally used to store large items both high and/or wide. When pulled out of the cabinet you have a drawer front attached to a flat surface on which the item sits. Roll-out shelves do not have sidewalls like drawers. Roll-out shelves use the same model numbers as cabinet drawers, which range from Model 20 to Model 90. Like the drawers, each model number represents a different usable height. Roll-out shelves can be used alone or in combination with drawers.

5. Shelf Cabinet Doors

Shelf cabinet doors come in six different heights ranging from 27-59 in. high, and are a single or double door configuration depending on the width of the housing. Each incorporates the same model number that is used for the cabinet heights listed below.

- 27 in. high - Model 135
- 30 in. high - Model 155
- 33 in. high - Model 175
- 37 in. high - Model 200
- 44 in. high - Model 245
- 59 in. high - Model 340

*Shelf cabinet doors can not be used with roll-out shelves pictured in section 4.
(Special recessed roll-out shelves must be ordered.)*

Like the model numbers used for the cabinet drawers and roll-out shelves, the cabinet door model number, if used alone, must equal the cabinet height model number. Thus a cabinet height of 59 in. (Model 340) would use a cabinet door that incorporates 340 (59 in. size) into its part number. When the cabinet door matches the size of the cabinet height, only cabinet shelves can be used internally. You can combine cabinet doors that are smaller in height than the cabinet housing with drawers and roll-out shelves, but the sum total of the model numbers for all must equal the cabinet height model number.



4.



5.



HOW TO BUILD A CUSTOM CABINET

CABINET FEATURES

6. Stationary Cabinet Shelves

Cabinet shelves can be used in a cabinet that's fitted with a cabinet door, with the housing alone, or in any combination that includes a door (inside the section of housing that incorporates a door), drawers and roll-out shelves. The number of shelves that will fit in a specific housing depends on the size of the material to be stored. Cabinet shelves can be placed every 3/4 in. inside a housing. (No tools required for movement of shelves.)

7. Bottom Pan

Bottom pans are included when ordering a shelf cabinet or a shelf door cabinet. Their function is to provide a flat surface that is level with the base of the cabinet so that items stored in its bottom can be easily retrieved.

8. Locks

Offering a wide range of lock options.

6.



Standard



Shallow Depth



Small Version



Extra Wide Shallow Depth



Extra Wide



Double Wide Shallow Depth

7.



Standard



Shallow Depth



Small Version



Extra Wide



Extra Wide
Shallow Depth



Double Wide
Shallow Depth



8. Security Drawer Locks



Multiple Cabinet Lock

Individual Drawer Padlock

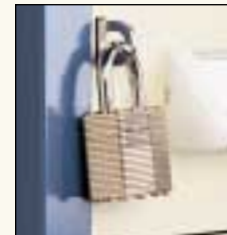

Standard Drawer Lock

Lock In/Lock Out Latch



Hinge Lock Bar



To protect inventory, the Stanley® Vidmar® keying system is virtually impossible to duplicate.

Toll Free Customer Service Number: 1-800-523-9462
Customer Service FAX Number: 1-800-523-9934

Standard Cabinets

Standard Housings (A)

Standard housings are 30 in. (762 mm) wide and 27-3/4 in. (705 mm) deep.

Note: Dimensions do not include 1-1/4 in. (32 mm) drawer pulls. Housings will accept drawers, roll-out shelves, and stationary shelves in any combination

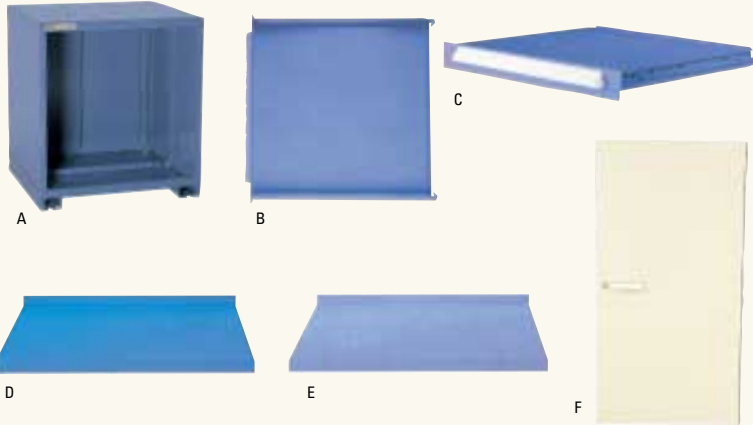

Standard Drawers (B)

Standard drawer interiors are 25-1/8 in. (638 mm) wide and 25-1/8 in. (638 mm) deep. Available in 15 heights. Larger sizes available on request. Slots approximately 3/4 in. (19 mm) apart allow standard drawers to be divided into 32 equal spaces left to right and front to back. If ordered separately, suspension system is included with each drawer. Usable height is measured from inside bottom of drawer to top of drawer front. Operating capacity is 400 lbs (181 kg).

Standard Roll-Out Shelves (C)

Standard roll-out shelves are 26-1/8 in. (664 mm) wide and 26 in. (660 mm) deep (usable area). Available in 15 heights. Larger sizes available on request. Reinforced roll-out shelves are adjustable within a cabinet housing. When ordered separately, all roll-out shelves include suspension system. Operating capacity is 400 lbs (181 kg).

Standard Shelves (D)

Shelves for cabinets should be ordered separately. Adjustable in increments of approximately 3/4 in. (19 mm). Shelves are 25-1/4 in. W (641 mm) by 27-1/4 in. D (692 mm).

Standard Bottom Pans (E)

Bottom pans are included when ordering shelf cabinets or shelf door cabinets. For all other cabinets bottom pans must be ordered separately.

Standard Shelf Cabinet Doors (F)

Doors for standard shelf cabinets are available with a piano-style hinge, two point engagement, and magnetic catch. To order a cabinet with a door, use the prefix "SD". Indicate RH or LH for right-hand or left-hand opening.

Standard Housings (A)

MODEL#	FOR USE AS	OVERALL HEIGHT IN. (MM)
0135	Desk	27 in. (686 mm)
0155	Table	30 in. (762 mm)
0175	Bench	33 in. (838 mm)
0200	Stool	37 in. (940 mm)
0245	Counter	44 in. (1118 mm)
0340	Eye level	59 in. (1499 mm)

Standard Drawers (B)

MODEL#	USABLE HEIGHT IN. (MM)	MODEL#	USABLE HEIGHT IN. (MM)
20	2-1/4 in. (57 mm)	60	8-1/2 in. (216 mm)
25	3 in. (76 mm)	65	9-3/8 in. (238 mm)
30	3-7/8 in. (98 mm)	70	10-1/8 in. (257 mm)
35	4-5/8 in. (117 mm)	75	10-7/8 in. (276 mm)
40	5-3/8 in. (137 mm)	80	11-3/4 in. (298 mm)
45	6-1/4 in. (159 mm)	85	12-1/2 in. (318 mm)
50	7 in. (178 mm)	90	13-1/4 in. (337 mm)
55	7-3/4 in. (197 mm)		

Standard Roll-Out Shelves (C)

MODEL#	USABLE HEIGHT IN. (MM)	MODEL#	USABLE HEIGHT IN. (MM)
RS20	1/4 in. (6 mm)	RS60	6-1/2 in. (165 mm)
RS25	1 in. (25 mm)	RS65	7-1/4 in. (184 mm)
RS30	1-3/4 in. (44 mm)	RS70	8-1/8 in. (206 mm)
RS35	2-5/8 in. (67 mm)	RS75	8-7/8 in. (225 mm)
RS40	3-3/8 in. (86 mm)	RS80	9-5/8 in. (244 mm)
RS45	4-1/8 in. (105 mm)	RS85	10-1/2 in. (267 mm)
RS50	4-7/8 in. (124 mm)	RS90	11-1/4 in. (286 mm)
RS55	5-3/4 in. (146 mm)		

Standard Shelves (D)

MODEL#	WEIGHT CAPACITY
CS40	400 lbs. (181 kg)
CS80	800 lbs. (363 kg)

*For lip feature, add suffix "L" to Model#

Standard Bottom Pans (E)

MODEL#
BP80

Standard Shelf Cabinet Doors (F)

MODEL#	FOR CABINET USE	OVERALL CABINET HEIGHT IN. (MM)
SDD135 RH or LH Door only	Desk	27 in. (686 mm)
SDD155 RH or LH Door only	Table	30 in. (762 mm)
SDD175 RH or LH Door only	Bench	33 in. (838 mm)
SDD200 RH or LH Door only	Stand-up	37 in. (940 mm)
SDD245 RH or LH Door only	Counter	44 in. (1118 mm)
SDD340 RH or LH Door only	Eye level	59 in. (1499 mm)

CUSTOM CABINETS

STANDARD & SHALLOW DEPTH

Shallow Depth Cabinets

Shallow Depth Housings (A)

Shallow depth housings are 30 in. (762 mm) wide and 21-38 in. (543 mm) deep.

Note: Dimensions do not include 1-1/4 in. (32 mm) drawer pulls. Housings will accept drawers, roll-out shelves, and stationary shelves in any combination.

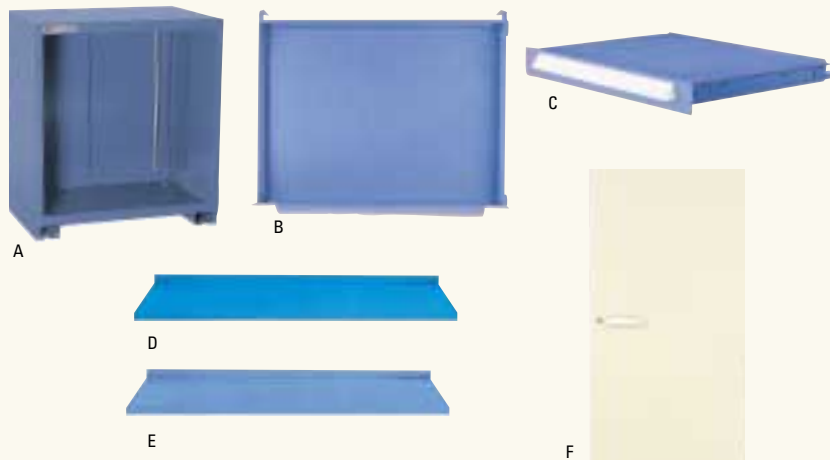

Shallow Depth Drawers (B)

Shallow depth drawers are 25-1/8 in. (638 mm) wide by 18-3/4 in. (476 mm) deep. Available in 15 heights. Larger sizes available on request. Slots approximately 3/4 in. (19 mm) apart allow shallow depth drawers to be divided into 32 spaces left to right and 24 spaces front to back. When ordered separately, suspension system is included with each drawer. Usable height is measured from inside bottom of drawer to top of drawer front. Operating capacity is 400 lbs (181 kg).

Shallow Depth Roll-Out Shelves (C)

Shallow depth roll-out shelves are 26-1/8 in. (667 mm) wide and 19-9/16 in. (497 mm) deep (usable area). Available in 15 heights. Larger sizes available on request. Reinforced roll-out shelves are adjustable within a cabinet housing. When ordered separately, all roll-out shelves include suspension system. Operating capacity is 400 lbs (181 kg).

Shallow Depth Shelves (D)

Shelves for cabinets should be ordered separately. Adjustable in increments of approximately 3/4 in. (19 mm). Shelves are 27-1/4 in. (695 mm) by 18-3/4 in. (476 mm).

Shallow Depth Bottom Pans (E)

Bottom pans are included when ordering shelf cabinets or shelf door cabinets. For all other cabinets bottom pans must be ordered separately.

Shallow Depth Shelf Cabinet Doors (F)

Doors for shallow depth shelf cabinets are available, with a piano-style hinge, two point engagement, and magnetic catch. To order a cabinet with a door, use the prefix "LWSD". Add RH for right-hand door and LH for left-hand door.

Shallow Depth Housings (A)

MODEL#	FOR USE AS	OVERALL HEIGHT	
		IN.	(MM)
LW0135	Desk	27 in.	(686 mm)
LW0155	Table	30 in.	(762 mm)
LW0175	Bench	33 in.	(838 mm)
LW0200	Stool	37 in.	(940 mm)
LW0245	Counter	44 in.	(1118 mm)
LW0340	Eye level	59 in.	(1499 mm)

Shallow Depth Drawers (B)

MODEL#	USABLE HEIGHT		MODEL#	USABLE HEIGHT	
	IN.	(MM)		IN.	(MM)
LW20	2-1/4 in.	(57 mm)	LW60	8-1/2 in.	(216 mm)
LW25	3 in.	(76 mm)	LW65	9-3/8 in.	(238 mm)
LW30	3-7/8 in.	(98 mm)	LW70	10-1/8 in.	(257 mm)
LW35	4-5/8 in.	(117 mm)	LW75	10-7/8 in.	(276 mm)
LW40	5-3/8 in.	(137 mm)	LW80	11-3/4 in.	(298 mm)
LW45	6-1/4 in.	(159 mm)	LW85	12-1/2 in.	(318 mm)
LW50	7 in.	(178 mm)	LW90	13-1/4 in.	(337 mm)
LW55	7-3/4 in.	(197 mm)			

Shallow Depth Roll-Out Shelves (C)

MODEL#	USABLE HEIGHT		MODEL#	USABLE HEIGHT	
	IN.	(MM)		IN.	(MM)
LWRS20	1/4 in.	(6 mm)	LWRS60	6-1/2 in.	(165 mm)
LWRS25	1 in.	(25 mm)	LWRS65	7-1/4 in.	(184 mm)
LWRS30	1-3/4 in.	(44 mm)	LWRS70	8-1/8 in.	(206 mm)
LWRS35	2-5/8 in.	(67 mm)	LWRS75	8-7/8 in.	(225 mm)
LWRS40	3-3/8 in.	(86 mm)	LWRS80	9-5/8 in.	(244 mm)
LWRS45	4-1/8 in.	(105 mm)	LWRS85	10-1/2 in.	(267 mm)
LWRS50	4-7/8 in.	(124 mm)	LWRS90	11-1/4 in.	(286 mm)
LWRS55	5-3/4 in.	(146 mm)			

Shallow Depth Shelves (D)

MODEL#	WEIGHT CAPACITY
LWCS40	400 lbs. (181 kg)
LWCS80	800 lbs. (363 kg)

Shallow Depth Bottom Pans (E)

*For lip feature, add suffix "L" to Model#

MODEL#
LWBP80

Shallow Depth Shelf Cabinet Doors (F)

MODEL#	FOR CABINET USE	OVERALL CABINET HEIGHT	
		IN.	(MM)
LWSD135 Door only	Desk	27 in.	(686 mm)
LWSD155 Door only	Table	30 in.	(762 mm)
LWSD175 Door only	Bench	33 in.	(838 mm)
LWSD200 Door only	Stand-up	37 in.	(940 mm)
LWSD245 Door only	Counter	44 in.	(1118 mm)
LWSD340 Door only	Eye level	59 in.	(1499 mm)

Toll Free Customer Service Number: 1-800-523-9462
Customer Service FAX Number: 1-800-523-9934

Small Version Cabinets

Small Version Housings (A)

Small version housings are 22-1/2 in. (572 mm) wide and 27-3/4 in. (705 mm) deep.

Note: Dimensions do not include 1-1/4 in. (32 mm) drawer pulls. Housings will accept drawers, roll-out shelves, and stationary shelves with or without drawers.

Small Version Drawers (B)

Small version drawers are 17-7/8 in. (454 mm) wide and 25-1/8 in. (638 mm) deep. Available in 15 drawer heights. Slots approximately 3/4 in. (19 mm) apart allow small version drawers to be divided into 23 spaces left to right and 32 spaces front to back. When ordered separately, suspension system is included with each drawer.

Drawer sizes other than those listed are available on special request. Usable height is measured from inside bottom of drawer to top of drawer front. Operating capacity is 400 lbs (181 kg).

Small Version Roll-Out Shelves (C)

Small version roll-out shelves are 19-1/8 in. (486 mm) wide and 25-9/16 in. (649 mm) deep (usable area). Available in 15 heights. Roll-out shelf sizes other than those listed are available on special request. Reinforced roll-out shelves are adjustable within a cabinet housing. When ordered separately, all roll-out shelves include suspension system. Operating capacity is 400 lbs (181 kg).

Small Version Shelves (D)

Shelves for cabinets should be ordered separately. Adjustable in increments of approximately 3/4 in. (19 mm). Shelves are 18 in. (457 mm) by 25 in. (635 mm).

Small Version Bottom Pans (E)

Bottom pans are included when ordering shelf cabinets or shelf door cabinets. For all other cabinets bottom pans must be ordered separately.

Small Version Shelf Cabinet Doors (F)

Doors for small version size shelf cabinets are available with a piano-style hinge, two point engagement and magnetic catch. To order a cabinet with a door, use the prefix "SVSD". Add RH for right-hand door, LH for left-hand door.

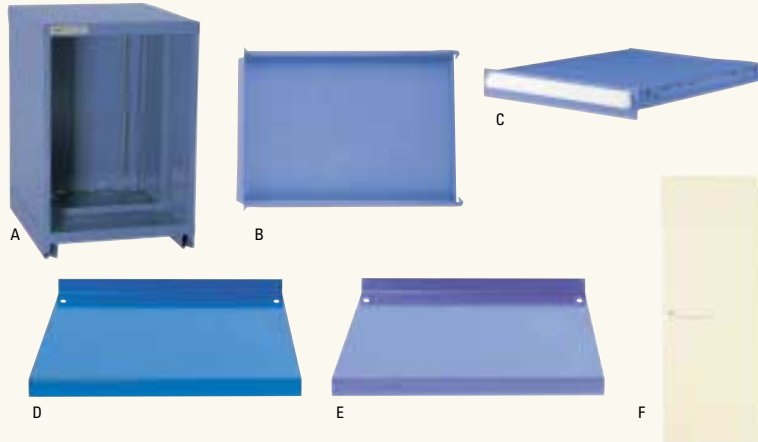

Small Version Housings (A)

MODEL#	FOR USE AS	OVERALL HEIGHT	
		IN.	(MM)
SV0135	Desk	27 in.	(686 mm)
SV0155	Table	30 in.	(762 mm)
SV0175	Bench	33 in.	(838 mm)
SV0200	Stool	37 in.	(940 mm)
SV0245	Counter	44 in.	(1118 mm)
SV0340	Eye level	59 in.	(1499 mm)

Small Version Drawers (B)

MODEL#	USABLE HEIGHT		MODEL#	USABLE HEIGHT	
	IN.	(MM)		IN.	(MM)
SV20	2-1/4 in.	(57 mm)	SV60	8-1/2 in.	(216 mm)
SV25	3 in.	(76 mm)	SV65	9-3/8 in.	(238 mm)
SV30	3-7/8 in.	(98 mm)	SV70	10-1/8 in.	(257 mm)
SV35	4-5/8 in.	(117 mm)	SV75	10-7/8 in.	(276 mm)
SV40	5-3/8 in.	(137 mm)	SV80	11-3/4 in.	(298 mm)
SV45	6-1/4 in.	(159 mm)	SV85	12-1/2 in.	(318 mm)
SV50	7 in.	(178 mm)	SV90	13-1/4 in.	(337 mm)
SV55	7-3/4 in.	(197 mm)			

Small Version Roll-Out Shelves (C)

MODEL#	USABLE HEIGHT		MODEL#	USABLE HEIGHT	
	IN.	(MM)		IN.	(MM)
SVRS20	1/4 in.	(6 mm)	SVRS60	6-1/2 in.	(165 mm)
SVRS25	1 in.	(25 mm)	SVRS65	7-1/4 in.	(184 mm)
SVRS30	1-3/4 in.	(44 mm)	SVRS70	8-1/8 in.	(206 mm)
SVRS35	2-5/8 in.	(67 mm)	SVRS75	8-7/8 in.	(225 mm)
SVRS40	3-3/8 in.	(86 mm)	SVRS80	9-5/8 in.	(244 mm)
SVRS45	4-1/8 in.	(105 mm)	SVRS85	10-1/2 in.	(267 mm)
SVRS50	4-7/8 in.	(124 mm)	SVRS90	11-1/4 in.	(286 mm)
SVRS55	5-3/4 in.	(146 mm)			

Small Version Shelves (D)

MODEL#	WEIGHT CAPACITY
SVCS40	400 lbs. (181 kg)
SVCS80	800 lbs. (363 kg)

Small Version Bottom Pans (E)

*For lip feature, add suffix "L" to Model#

MODEL#
SVBP80

Small Version Shelf Cabinet Doors (F)

MODEL#	FOR CABINET USE	OVERALL CABINET HEIGHT	
		IN.	(MM)
SVSDD135 Door only	Desk	27 in.	(686 mm)
SVSDD155 Door only	Table	30 in.	(762 mm)
SVSDD175 Door only	Bench	33 in.	(838 mm)
SVSDD200 Door only	Stand-up	37 in.	(940 mm)
SVSDD245 Door only	Counter	44 in.	(1118 mm)
SVSDD340 Door only	Eye level	59 in.	(1499 mm)

CUSTOM CABINETS

SMALL VERSION & SMALL VERSION SHALLOW DEPTH

Small Version Shallow Depth Cabinets

Small Version Shallow Depth Housings (A)

Small version shallow depth housings are 22-1/2 in. (572 mm) wide and 21-3/8 in. (543 mm) deep.

Note: Dimensions do not include 1-1/4 in. (32 mm) drawer pulls. Housings will accept drawers, roll-out shelves, and stationary shelves with or without drawers.

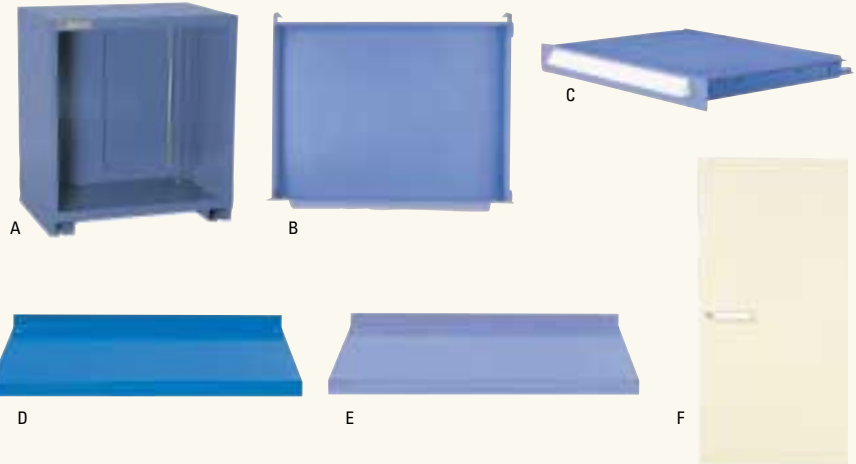

Small Version Shallow Depth Drawers (B)

Small version shallow depth drawers are 17-7/8 in. (454 mm) wide by 18-3/4 in. (476 mm) deep. Available in 15 drawer heights. Drawer sizes other than those listed are available on special request. Slots approximately 3/4 in. (19 mm) apart allow shallow depth drawers to be divided into 23 spaces left to right and 24 spaces front to back. When ordered separately, suspension system is included with each drawer. Usable height is measured from inside bottom of drawer to top of drawer front. Operating capacity is 400 lbs (181 kg).

Small Version Shallow Depth Roll-Out Shelves (C)

Small version shallow depth roll-out shelves are 19-1/8 in. (486 mm) wide and 19-9/16 in. (497 mm) deep (usable area). Available in 15 heights. Roll-out shelf sizes other than those listed are available on special request. Reinforced roll-out shelves are adjustable within a cabinet housing. When ordered separately, all roll-out shelves include suspension system. Operating capacity is 400 lbs (181 kg).

Small Version Shallow Depth Shelves (D)

Shelves for cabinets should be ordered separately. Adjustable in increments of approximately 3/4 in. (19 mm). Shelves are 18 in. (457 mm) by 18-3/4 in. (476 mm).

Small Version Shallow Depth Bottom Pans (E)

Bottom pans are included when ordering shelf cabinets or shelf door cabinets. For all other cabinets bottom pans must be ordered separately.

Small Version Shallow Depth Shelf Cabinet Doors (F)

Doors for shallow depth size shelf cabinets are available, with a piano-style hinge, two point engagement and magnetic catch. To add locks, To order a cabinet with a door, use the prefix "SVSD". Add RH for right-hand door and LH for left-hand door.

Small Version Shallow Depth Housings (A)

MODEL#	FOR USE AS	OVERALL HEIGHT	
		IN.	(MM)
SL0135	Desk	27 in.	(686 mm)
SL0155	Table	30 in.	(762 mm)
SL0175	Bench	33 in.	(838 mm)
SL0200	Stool	37 in.	(940 mm)
SL0245	Counter	44 in.	(1118 mm)
SL0340	Eye level	59 in.	(1499 mm)

Small Version Shallow Depth Drawers (B)

MODEL#	USABLE HEIGHT		MODEL#	USABLE HEIGHT	
	IN.	(MM)		IN.	(MM)
SL20	2-1/4 in.	(57 mm)	SL60	8-1/2 in.	(216 mm)
SL25	3 in.	(76 mm)	SL65	9-3/8 in.	(238 mm)
SL30	3-7/8 in.	(98 mm)	SL70	10-1/8 in.	(257 mm)
SL35	4-5/8 in.	(117 mm)	SL75	10-7/8 in.	(276 mm)
SL40	5-3/8 in.	(137 mm)	SL80	11-3/4 in.	(298 mm)
SL45	6-1/4 in.	(159 mm)	SL85	12-1/2 in.	(318 mm)
SL50	7 in.	(178 mm)	SL90	13-1/4 in.	(337 mm)
SL55	7-3/4 in.	(197 mm)			

Small Version Shallow Depth Roll-Out Shelves (C)

MODEL#	USABLE HEIGHT		MODEL#	USABLE HEIGHT	
	IN.	(MM)		IN.	(MM)
SLRS20	1/4 in.	(6 mm)	SLRS60	6-1/2 in.	(165 mm)
SLRS25	1 in.	(25 mm)	SLRS65	7-1/4 in.	(184 mm)
SLRS30	1-3/4 in.	(44 mm)	SLRS70	8-1/8 in.	(206 mm)
SLRS35	2-5/8 in.	(67 mm)	SLRS75	8-7/8 in.	(225 mm)
SLRS40	3-3/8 in.	(86 mm)	SLRS80	9-5/8 in.	(244 mm)
SLRS45	4-1/8 in.	(105 mm)	SLRS85	10-1/2 in.	(267 mm)
SLRS50	4-7/8 in.	(124 mm)	SLRS90	11-1/4 in.	(286 mm)
SLRS55	5-3/4 in.	(146 mm)			

Small Version Shallow Depth Shelves (D)

MODEL#	WEIGHT CAPACITY
SLCS40	400 lbs. (181 kg)
SLCS80	800 lbs. (363 kg)

Small Version Shallow Depth Bottom Pans (E)

**For lip feature, add suffix "L" to Model#*

MODEL#
SLBP80

Small Version Shallow Depth Shelf Cabinet Doors (F)

MODEL#	FOR CABINET USE	OVERALL CABINET HEIGHT	
		IN.	(MM)
SVSDD135 RH or LH Door only	Desk	27 in.	(686 mm)
SVSDD155 RH or LH Door only	Table	30 in.	(762 mm)
SVSDD175 RH or LH Door only	Bench	33 in.	(838 mm)
SVSDD200 RH or LH Door only	Stand-up	37 in.	(940 mm)
SVSDD245 RH or LH Door only	Counter	44 in.	(1118 mm)
SVSDD340 RH or LH Door only	Eye level	59 in.	(1499 mm)

Toll Free Customer Service Number: 1-800-523-9462
Customer Service FAX Number: 1-800-523-9934

Extra Wide Cabinets

Extra Wide Housings (A)

Extra wide housings are 45 in. (1143 mm) wide and 27-3/4 in. (705 mm) deep.

Note: Dimensions do not include 1-1/4 in. (32 mm) drawer pulls. Housings will accept drawers, roll-out shelves, and adjustable shelves with or without drawers.

Extra Wide Drawers (B)

Extra wide drawers are 40-1/4 in. (1029 mm) wide and 25-1/8 in. (638 mm) deep. Available in 15 drawer heights. Drawer sizes other than those listed are available on special request. Slots approximately 3/4 in. (19 mm) apart allow extra wide drawers to be divided into 51 spaces left to right and 32 spaces front to back. When ordered separately, suspension system is included with each drawer. Usable height is measured from inside bottom of drawer to top of drawer front. Operating capacity is 400 lbs (181 kg).

Extra Wide Roll-Out Shelves (C)

Extra wide roll-out shelves are 41-1/4 in. (1048 mm) wide and 26 in. (660 mm) deep (usable area). Available in 15 heights. Roll-out shelf sizes other than those listed are available on special request. Reinforced roll-out shelves are adjustable within a cabinet housing. When ordered separately, all roll-out shelves include suspension system. Operating capacity is 400 lbs (181 kg).

Extra Wide Shelves (D)

Shelves for cabinets should be ordered separately. Adjustable in increments of approximately 3/4 in. (19 mm). Shelves are 42-1/2 in. (1080 mm) by 25 in. (635 mm).

Extra Wide Bottom Pan (E)

Bottom pans are included when ordering shelf cabinets or shelf door cabinets. For all other cabinets bottom pans must be ordered separately.

Extra Wide Shelf Cabinet Doors (F)

Doors for extra wide size shelf cabinets are available, with a piano-style hinge, two point engagement, and magnetic catch. To order a cabinet with a door, use the prefix "XWSD."



Extra Wide Housings (A)

MODEL#	FOR USE AS	OVERALL HEIGHT	
		IN.	(MM)
XW0135	Desk	27 in.	(686 mm)
XW0155	Table	30 in.	(762 mm)
XW0175	Bench	33 in.	(838 mm)
XW0200	Stool	37 in.	(940 mm)
XW0245	Counter	44 in.	(1118 mm)
XW0340	Eye level	59 in.	(1499 mm)

Extra Wide Drawers (B)

MODEL#	USABLE HEIGHT		MODEL#	USABLE HEIGHT	
	IN.	(MM)		IN.	(MM)
XW20	2-1/4 in.	(57 mm)	XW60	8-1/2 in.	(216 mm)
XW25	3 in.	(76 mm)	XW65	9-3/8 in.	(238 mm)
XW30	3-7/8 in.	(98 mm)	XW70	10-1/8 in.	(257 mm)
XW35	4-5/8 in.	(117 mm)	XW75	10-7/8 in.	(276 mm)
XW40	5-3/8 in.	(137 mm)	XW80	11-3/4 in.	(298 mm)
XW45	6-1/4 in.	(159 mm)	XW85	12-1/2 in.	(318 mm)
XW50	7 in.	(178 mm)	XW90	13-1/4 in.	(337 mm)
XW55	7-3/4 in.	(197 mm)			

Extra Wide Roll-Out Shelves (C)

MODEL#	USABLE HEIGHT		MODEL#	USABLE HEIGHT	
	IN.	(MM)		IN.	(MM)
XWRS20	1/4 in.	(6 mm)	XWRS60	6-1/2 in.	(165 mm)
XWRS25	1 in.	(25 mm)	XWRS65	7-1/4 in.	(184 mm)
XWRS30	1-3/4 in.	(44 mm)	XWRS70	8-1/8 in.	(206 mm)
XWRS35	2-5/8 in.	(67 mm)	XWRS75	8-7/8 in.	(225 mm)
XWRS40	3-3/8 in.	(86 mm)	XWRS80	9-5/8 in.	(244 mm)
XWRS45	4-1/8 in.	(105 mm)	XWRS85	10-1/2 in.	(267 mm)
XWRS50	4-7/8 in.	(124 mm)	XWRS90	11-1/4 in.	(286 mm)
XWRS55	5-3/4 in.	(146 mm)			

Extra Wide Shelves (D)

MODEL#	WEIGHT CAPACITY
XWCS40	400 lbs. (181 kg)
XWCS80	800 lbs. (363 kg)

Extra Wide Bottom Pan (E)

*For lip feature, add suffix "L" to Model#

MODEL#
XWBP80

Extra Wide Shelf Cabinet Doors (F)

MODEL#	FOR CABINET USE	OVERALL CABINET HEIGHT	
		IN.	(MM)
XWSDD135 Door only	Desk	27 in.	(686 mm)
XWSDD155 Door only	Table	30 in.	(762 mm)
XWSDD175 Door only	Bench	33 in.	(838 mm)
XWSDD200 Door only	Stand-up	37 in.	(940 mm)
XWSDD245 Door only	Counter	44 in.	(1118 mm)
XWSDD340 Door only	Eye level	59 in.	(1499 mm)

CUSTOM CABINETS

EXTRA WIDE & EXTRA WIDE SHALLOW DEPTH

Extra Wide Shallow Depth Cabinets

Extra Wide Shallow Depth Housings (A)

Extra wide shallow depth housings are 45 in. (1143 mm) wide and 2-138 in. (543 mm) deep.

Note: Dimensions do not include 1/4 in. (32 mm) drawer pulls. Housings will accept drawers, roll-out shelves, and adjustable shelves with or without drawers.

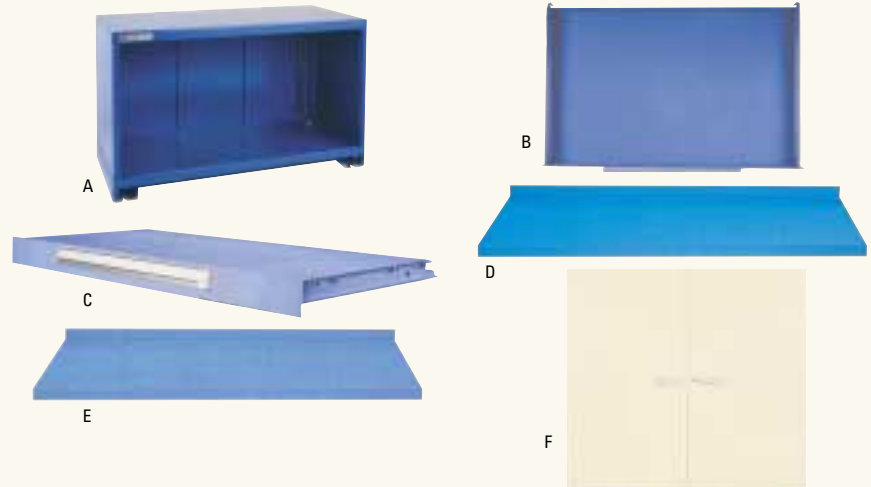

Extra Wide Shallow Depth Drawers (B)

Extra wide shallow depth drawers are 40-1/2 in. (1029 mm) wide and 18-3/4 in. (476 mm) deep. Available in 15 heights. Larger sizes available on request. Slots approximately 3/4 in. (19 mm) apart allow extra wide shallow depth drawers to be divided into 51 left to right and 23 spaces front to back. When ordered separately, suspension system is included with each drawer. Usable height is measured from inside bottom of drawer to top of drawer front. Operation capacity is 400 lbs (181 kg).

Extra Wide Shallow Depth Roll-Out Shelves (C)

Extra wide shallow depth roll-out shelves are 41-1/4 in. (1048 mm) wide and 19-9/16 in. (497 mm) deep (usable area). Available in four heights. Drawer sizes other than those listed are available on special request. Reinforced roll-out shelves are adjustable within a cabinet housing. When ordered separately, all roll-out shelves include suspension system. Operating capacity is 400 lbs (181 kg).

Extra Wide Shallow Depth Shelves (D)

Shelves for cabinets should be ordered separately. Adjustable in increments of approximately 3/4 in. (19 mm). Shelves are 42-1/2 in. (1080 mm) by 18-3/4 in. (476 mm).

Extra Wide Shallow Depth Bottom Pan (E)

Bottom pans are included when ordering shelf cabinets or shelf door cabinets. For all other cabinets bottom pans must be ordered separately.

Extra Wide Shallow Depth Shelf Cabinet Doors (F)

Doors for extra wide shallow depth size shelf cabinets are available, with a piano-style hinge, two point engagement, and magnetic catch. To order a cabinet with a door, use the prefix "XLSD."

Extra Wide Shallow Depth Housings (A)

MODEL#	FOR USE AS	OVERALL HEIGHT	
		IN.	(MM)
XL0135	Desk	27 in.	(686 mm)
XL0155	Table	30 in.	(762 mm)
XL0175	Bench	33 in.	(838 mm)
XL0200	Stool	37 in.	(940 mm)
XL0245	Counter	44 in.	(1118 mm)
XL0340	Eye level	59 in.	(1499 mm)

Extra Wide Shallow Depth Drawers (B)

MODEL#	USABLE HEIGHT		MODEL#	USABLE HEIGHT	
	IN.	(MM)		IN.	(MM)
XL20	2-1/4 in.	(57 mm)	XL60	8-1/2 in.	(216 mm)
XL25	3 in.	(76 mm)	XL65	9-3/8 in.	(238 mm)
XL30	3-7/8 in.	(98 mm)	XL70	10-1/8 in.	(257 mm)
XL35	4-5/8 in.	(117 mm)	XL75	10-7/8 in.	(276 mm)
XL40	5-3/8 in.	(137 mm)	XL80	11-3/4 in.	(298 mm)
XL45	6-1/4 in.	(159 mm)	XL85	12-1/2 in.	(318 mm)
XL50	7 in.	(178 mm)	XL90	13-1/4 in.	(337 mm)
XL55	7-3/4 in.	(197 mm)			

Extra Wide Shallow Depth Roll-Out Shelves (C)

MODEL#	USABLE HEIGHT	
	IN.	(MM)
XLRS20	1/4 in.	(6 mm)
XLRS70	8-1/8 in.	(206 mm)
XLRS80	9-5/8 in.	(244 mm)
XLRS85	10-1/2 in.	(267 mm)

Extra Wide Shallow Depth Shelves (D)

MODEL#	WEIGHT CAPACITY
XLCS40	400 lbs. (181 kg)
XLCS80	800 lbs. (363 kg)

*For lip feature, add suffix "L" to Model#

Extra Wide Shallow Depth Bottom Pan (E)

MODEL#
XLBP80

Extra Wide Shallow Depth Shelf Cabinet Doors (F)

MODEL#	FOR CABINET USE	OVERALL CABINET HEIGHT	
		IN.	(MM)
XWSD135 Door only	Desk	27 in.	(686 mm)
XWSD155 Door only	Table	30 in.	(762 mm)
XWSD175 Door only	Bench	33 in.	(838 mm)
XWSD200 Door only	Stand-up	37 in.	(940 mm)
XWSD245 Door only	Counter	44 in.	(1118 mm)
XWSD340 Door only	Eye level	59 in.	(1499 mm)

Toll Free Customer Service Number: 1-800-523-9462
Customer Service FAX Number: 1-800-523-9934

Double Wide Cabinets

Double Wide Housings (A)

Double wide housings are 60 in. (1524 mm) wide and 27-3/4 in. (705 mm) deep.

Note: Dimensions do not include 1-1/4 in. (32 mm) drawer pulls. Housings will accept drawers, roll-out shelves, and adjustable shelves with or without drawers.

Double Wide Drawers (B)

Double wide drawers are 55-3/8 in. (1407 mm) wide and 25-1/8 in. (638 mm) deep. Available in 15 drawer heights. Drawer sizes other than those listed are available on special request. Slots approximately 3/4 in. (19 mm) apart allow double wide drawers to be divided into 70 spaces left to right and 32 spaces front to back. When ordered separately, suspension system is included with each drawer. Usable height is measured from inside bottom of drawer to top of drawer front. Operating capacity is 400 lbs (181 kg).

Double Wide Roll-Out Shelves (C)

Double wide roll-out shelves are 56-3/8 in. (1432 mm) wide and 26 in. (660 mm) deep (usable area). Available in 15 heights. Roll-out shelf sizes other than those listed are available on special request. Reinforced roll-out shelves are adjustable within a cabinet housing. When ordered separately, all roll-out shelves include suspension system. Operating capacity is 400 lbs (181 kg).

Double Wide Shelves (D)

Shelves for cabinets should be ordered separately. Adjustable in increments of approximately 3/4 in. (19 mm). Shelves are 57-3/4 in. (1467 mm) by 25 in. (635 mm).

Double Wide Bottom Pan (E)

Bottom pans are included when ordering shelf cabinets or shelf door cabinets. For all other cabinets bottom pans must be ordered separately.

Double Wide Shelf Cabinet Doors (F)

Doors for double wide size shelf cabinets are available with a piano-style hinge, two point engagement, and magnetic catch. To order a cabinet with a door, use the prefix "DWSD."

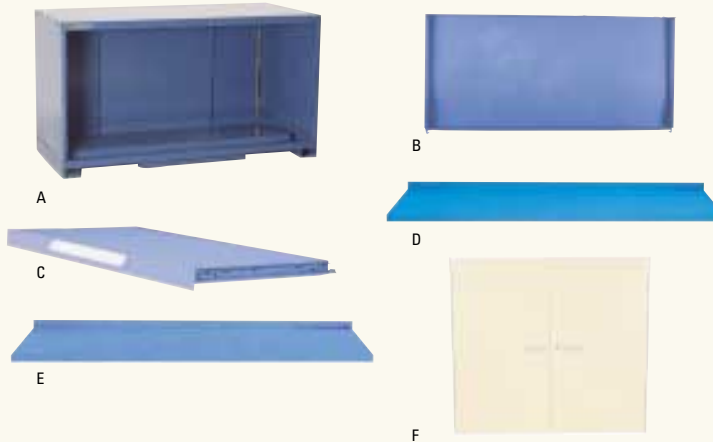

Double Wide Housings (A)

MODEL#	FOR USE AS	OVERALL HEIGHT IN.	OVERALL HEIGHT (MM)
DW0135	Desk	27 in.	(686 mm)
DW0155	Table	30 in.	(762 mm)
DW0175	Bench	33 in.	(838 mm)
DW0200	Stool	37 in.	(940 mm)
DW0245	Counter	44 in.	(1118 mm)
DW0340	Eye level	59 in.	(1499 mm)

Double Wide Drawers (B)

MODEL#	USABLE HEIGHT IN.	USABLE HEIGHT (MM)	MODEL#	USABLE HEIGHT IN.	USABLE HEIGHT (MM)
DW20	2-1/4 in.	(57 mm)	DW60	8-1/2 in.	(216 mm)
DW25	3 in.	(76 mm)	DW65	9-3/8 in.	(238 mm)
DW30	3-7/8 in.	(98 mm)	DW70	10-1/8 in.	(257 mm)
DW35	4-5/8 in.	(117 mm)	DW75	10-7/8 in.	(276 mm)
DW40	5-3/8 in.	(137 mm)	DW80	11-3/4 in.	(298 mm)
DW45	6-1/4 in.	(159 mm)	DW85	12-1/2 in.	(318 mm)
DW50	7 in.	(178 mm)	DW90	13-1/4 in.	(337 mm)
DW55	7-3/4 in.	(197 mm)			

Double Wide Roll-Out Shelves (C)

MODEL#	USABLE HEIGHT IN.	USABLE HEIGHT (MM)	MODEL#	USABLE HEIGHT IN.	USABLE HEIGHT (MM)
DWRS20	1/4 in.	(6 mm)	DWRS60	6-1/2 in.	(165 mm)
DWRS25	1 in.	(25 mm)	DWRS65	7-1/4 in.	(184 mm)
DWRS30	1-3/4 in.	(44 mm)	DWRS70	8-1/8 in.	(206 mm)
DWRS35	2-5/8 in.	(67 mm)	DWRS75	8-7/8 in.	(225 mm)
DWRS40	3-3/8 in.	(86 mm)	DWRS80	9-5/8 in.	(244 mm)
DWRS45	4-1/8 in.	(105 mm)	DWRS85	10-1/2 in.	(267 mm)
DWRS50	4-7/8 in.	(124 mm)	DWRS90	11-1/4 in.	(286 mm)
DWRS55	5-3/4 in.	(146 mm)			

Double Wide Shelves (D)

MODEL#	WEIGHT CAPACITY
DWCS40	400 lbs. (181 kg)
DWCS80	800 lbs. (363 kg)

*For lip feature, add suffix "L" to Model#

Extra Wide Bottom Pan (E)

MODEL#
DWBP80

Double Wide Shelf Cabinet Doors (F)

MODEL#	FOR CABINET USE	OVERALL CABINET HEIGHT IN.	OVERALL CABINET HEIGHT (MM)
DWSD135 Door only	Desk	27 in.	(686 mm)
DWSD155 Door only	Table	30 in.	(762 mm)
DWSD175 Door only	Bench	33 in.	(838 mm)
DWSD200 Door only	Stand-up	37 in.	(940 mm)
DWSD245 Door only	Counter	44 in.	(1118 mm)
DWSD340 Door only	Eye level	59 in.	(1499 mm)

CUSTOM CABINETS

DOUBLE WIDE & DOUBLE WIDE SHALLOW DEPTH

Double Wide Shallow Depth Cabinets

Double Wide Shallow Depth Housings (A)

Double wide shallow depth housings are 60 in. (1524 mm) wide and 21-3/8 in. (543 mm) deep.

Note: Dimensions do not include 1-1/4 in. (32 mm) drawer pulls. Housings will accept drawers, roll-out shelves, and adjustable shelves with or without drawers.

Double Wide Shallow Depth Drawers (B)

Double wide shallow depth drawers are 55-3/8 in. (1407 mm) wide and 18-3/4 in. (476 mm) deep.

Available in 15 drawer heights. Drawer sizes other than those listed are available on special request. Slots approximately 3/4 in. (19 mm) apart allow double wide shallow depth drawers to be divided into 70 left to right and 24 spaces front to back. When ordered separately, suspension system is included with each drawer. Usable height is measured from inside bottom of drawer to top of drawer front. Operation capacity is 400 lbs (181 kg).

Double Wide Shallow Depth Roll-Out Shelves (C)

Double wide shallow depth roll-out shelves are 56-3/8 in. (1432 mm) wide and 19-9/16 in. (497 mm) deep (usable area). Available in four heights. Roll-out shelf sizes other than those listed are available on special request.

Reinforced roll-out shelves are adjustable within a cabinet housing. When ordered separately, all roll-out shelves include suspension system. Operating capacity is 400 lbs (181 kg).

Double Wide Shallow Depth Shelves (D)

Shelves for cabinets should be ordered separately. Adjustable in increments of approximately 3/4 in. (19 mm). Shelves are 57-3/4 in. (1467 mm) by 18-3/4 in. (476 mm).

Double Wide Shallow Depth Bottom Pan (E)

Bottom pans are included when ordering shelf cabinets or shelf door cabinets. For all other cabinets bottom pans must be ordered separately.

Double Wide Shallow Depth Shelf Cabinet Doors (F)

Doors for double wide shallow depth size shelf cabinets are available, with a piano-style hinge, two point engagement, and magnetic catch. To order a cabinet with a door, use the prefix "DLSD."



Double Wide Shallow Depth Housings (A)

MODEL#	FOR USE AS	OVERALL HEIGHT IN.	(MM)
DL0135	Desk	27 in.	(686 mm)
DL0155	Table	30 in.	(762 mm)
DL0175	Bench	33 in.	(838 mm)
DL0200	Stool	37 in.	(940 mm)
DL0245	Counter	44 in.	(1118 mm)
DL0340	Eye level	59 in.	(1499 mm)

Double Wide Shallow Depth Drawers (B)

MODEL#	USABLE HEIGHT IN.	(MM)	MODEL#	USABLE HEIGHT IN.	(MM)
DL20	2-1/4 in.	(57 mm)	DL60	8-1/2 in.	(216 mm)
DL25	3 in.	(76 mm)	DL65	9-3/8 in.	(238 mm)
DL30	3-7/8 in.	(98 mm)	DL70	10-1/8 in.	(257 mm)
DL35	4-5/8 in.	(117 mm)	DL75	10-7/8 in.	(276 mm)
DL40	5-3/8 in.	(137 mm)	DL80	11-3/4 in.	(298 mm)
DL45	6-1/4 in.	(159 mm)	DL85	12-1/2 in.	(318 mm)
DL50	7 in.	(178 mm)	DL90	13-1/4 in.	(337 mm)
DL55	7-3/4 in.	(197 mm)			

Double Wide Shallow Depth Roll-Out Shelves (C)

MODEL#	USABLE HEIGHT IN.	(MM)
DLRS20	1/4 in.	(6 mm)
DLRS70	8-1/8 in.	(206 mm)
DLRS80	9-5/8 in.	(244 mm)
DLRS85	10-1/2 in.	(267 mm)

Double Wide Shallow Depth Shelves (D)

MODEL#	WEIGHT CAPACITY
DLCS40	400 lbs. (181 kg)
DLCS80	800 lbs. (363 kg)

Double Wide Shallow Depth Bottom Pan (E)

*For lip feature, add suffix "L" to Model#

MODEL#
DLBP80

Double Wide Shallow Depth Shelf Cabinet Doors (F)

MODEL#	FOR CABINET USE	OVERALL CABINET HEIGHT IN.	(MM)
DWSD135 Door only	Desk	27 in.	(686 mm)
DWSD155 Door only	Table	30 in.	(762 mm)
DWSD175 Door only	Bench	33 in.	(838 mm)
DWSD200 Door only	Stand-up	37 in.	(940 mm)
DWSD245 Door only	Counter	44 in.	(1118 mm)
DWSD340 Door only	Eye level	59 in.	(1499 mm)

Toll Free Customer Service Number: 1-800-523-9462
Customer Service FAX Number: 1-800-523-9934

Anatomy of a Workstation

The Stanley® Vidmar® system lets you tailor workstations to your specific needs. You choose from the most popular configurations, and add the components you need to do your kind of work. Because these workstations are built by Stanley Vidmar, you know you're getting high-quality, rugged, all-steel construction.

1. Stanley® Vidmar® Cabinet

The basic building block of the workstation is the cabinet. Workstation cabinets come in 30 in., 33 in. and 59 in. heights. Standard cabinets are 30 in. wide, and small-version cabinets are 22-1/2 in. wide. Both standard and small version cabinets are 27-3/4 in. deep.

2. Stanley® Vidmar® Drawers

Drawers come in 15 sizes from 2-1/4 in. to 13-1/4 in. high and are infinitely divisible to accommodate the widest possible assortment of articles. With Stanley® Vidmar® you can create a place for everything. Each drawer, regardless of height, can carry a load of up to 400 lbs (181 kg).

3. Work Surfaces

Work surfaces may be ordered in lengths, ranging from 30 in. to 120 in. Options include Hardwood, Plastic, Static-Dissipative Materials, Steel and Stainless Steel.

4. Back and End Stops

Back and end stops may be ordered to help keep small parts from rolling off the work surface.

5. Riser Shelves and Back Panels

Working area and efficiency are increased with riser shelves. These shelves provide ready space for test instruments, components, and a convenient place to keep tools out of the way.

6. Accessories

Stanley Vidmar offers a full complement of workstation accessories, from footrests to electrical outlet strips so you can set up each workstation to suit your specific needs.

7. Fluorescent Lights

Choose one of three sizes of fluorescent lights available from Stanley Vidmar to light your workspace.

Available in ESD Protective or StaticGard®

With special non-flaking, black, static-dissipative paint, conductive work surface, and appropriate accessories, any cabinet can be part of a static-safe work environment.

Built-in Pallet Feet Provide Extra Mobility

Integral to the base of each cabinet are built-in pallet feet to make moving – even fully loaded – an easy job. Cabinets may be moved from the front or back.

Ergonomic workstations

Available.

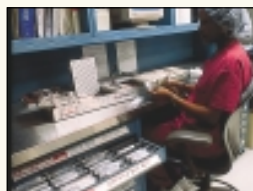
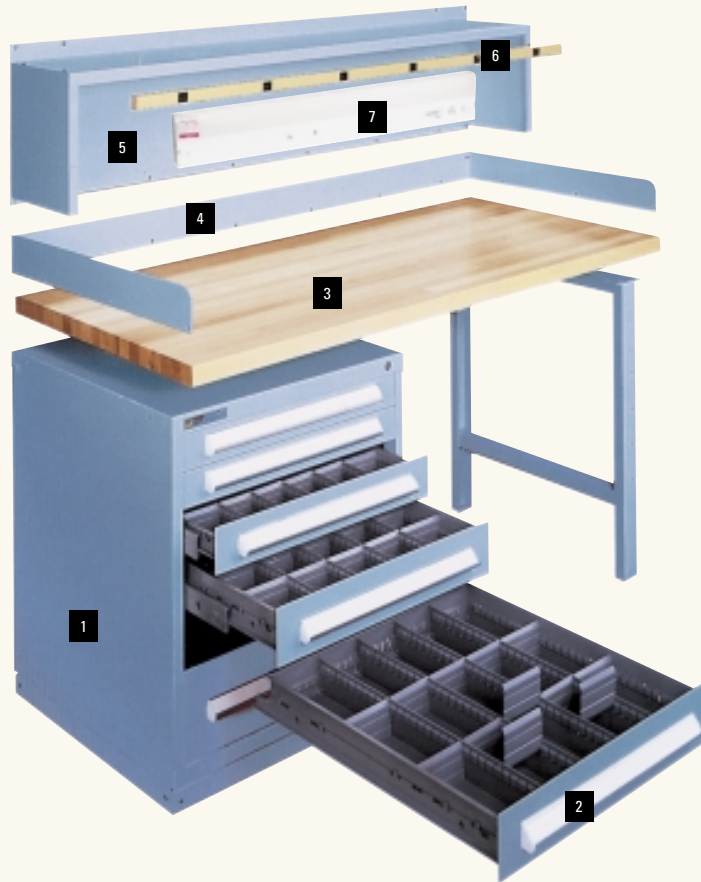

Stanley® Vidmar® workstations are available with a variety of work surfaces. Options include hardwood, plastic, dissipative material, steel plates, and stainless steel.

Because they're versatile and can be configured in a vast number of ways, Stanley® Vidmar® modular cabinets are found in a variety of industries and applications.

Using modular cabinets outfitted with a combination of drawers, doors, and casters, several state-of-the-art mobile workstations were built for the Valvoline race team.

WORKSTATIONS & BENCHING

STRAIGHT

Workstations & Benching

Type A Straight Workstations

These attractive, rugged workstations are designed to meet today's demanding benching requirements. The modular characteristics of the workstations provide many different benching options. And when relocation becomes necessary, moving the modular workstation is easy. Disassembly is simple, as is moving fully loaded cabinets. To meet your specific workstation needs, simply select the exact storage components and work surface that match your requirements. And remember... you can always add to any modular workstation when expansion becomes necessary.



Type A

Specific Configurations



A-1

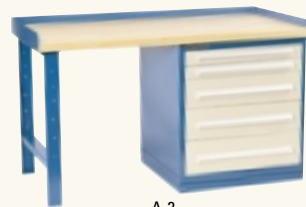

A-2



A-3



A-4



A-5



A-6



A-7



A-8



A-9



A-10



A-11



A-12

Toll Free Customer Service Number: 1-800-523-9462
Customer Service FAX Number: 1-800-523-9934

Workstations & Benching

Type B Corner Workstations

Stanley® Vidmar® corner workstations fill a specific need in benching requirements for corner and right-angle configurations. Wasted corner space is eliminated. Cabinets, work surfaces, and a complete line of accessories flow at right angles for maximum operator efficiency and convenience. Drawer storage is never more than a comfortable arm's length away. Right-angle capabilities now offer unlimited work center layouts in clusters configured face-to-face, back-to-back, or side-by-side to take full advantage of available space, lighting, and room layout.



Type B

Specific Configurations

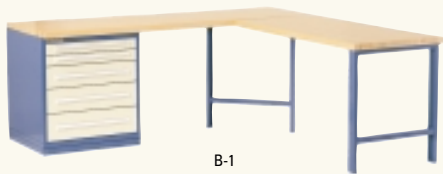

B-1

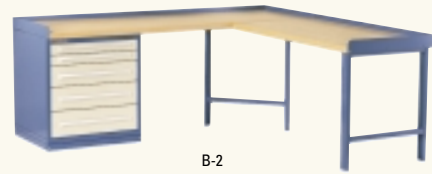

B-2

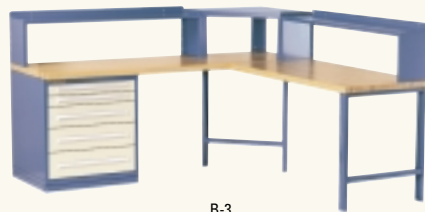

B-3

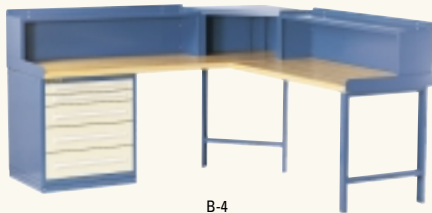

B-4



B-5

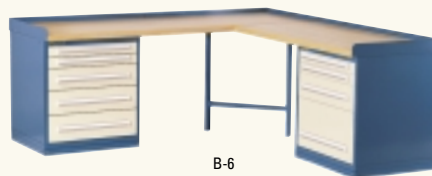

B-6

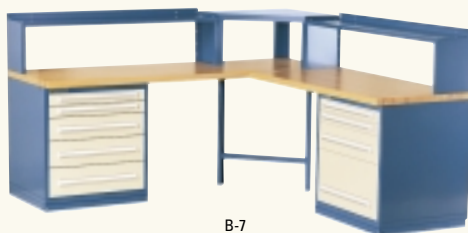

B-7



B-8

WORKSTATIONS & BENCHING

CORNER AND HI-LO

Workstations & Benching

Type C Hi-Lo Workstations

Hi-lo workstations offer a wide variety of configurations with maximum storage capacity by using the full range of modular storage drawer cabinets with various work surface designs. You may select the right combinations that meet your workstation requirements without being restricted by floor space allocations and materials to be stored or used in the workstation. Drawers can be easily arranged so their labels, compartments, and contents are always facing the operator, in order to keep moving, reaching, and lifting to a minimum.



Specific Configurations

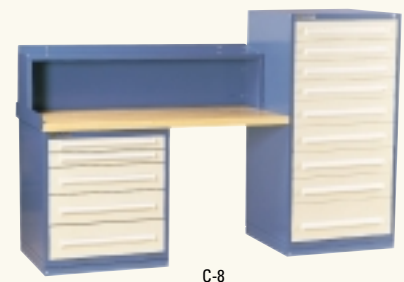
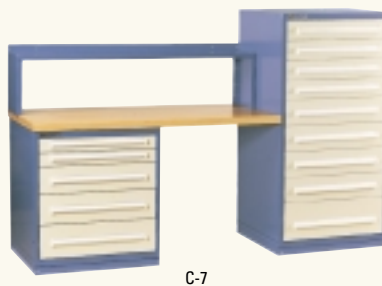
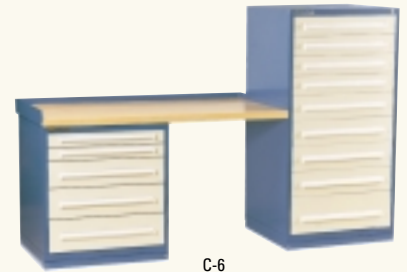
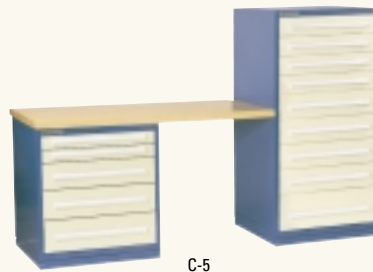
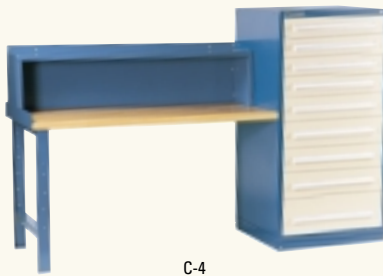
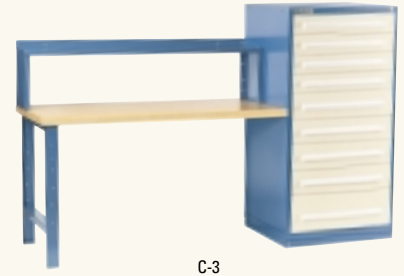
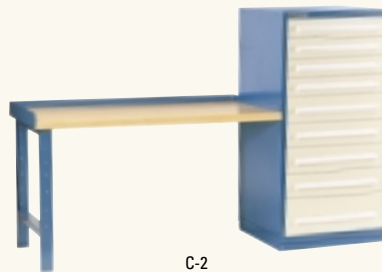
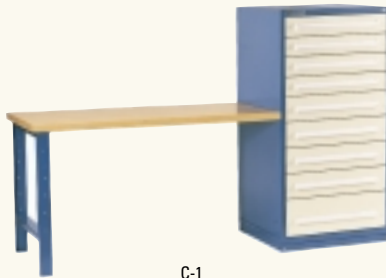

Workstations & Benching

Type D Center Workstations

This center cabinet configuration is ideal for two-person workstations where each worker uses common parts and supplies, or shares work in process. Additional cabinets can be added so that each worker has parts and supplies specifically needed for an operation, and can draw on parts from the central, common storage cabinet. As with all workstations, there's no need to bend or stoop to look into hidden shelves, because the heavy-duty Stanley® Vidmar® drawers roll easily out of the cabinets into full view for maximum efficiency.



Specific Configurations



D-1



D-2



D-3



D-4

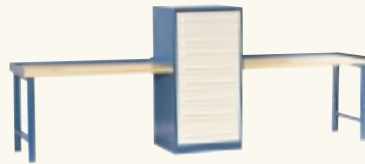

D-5

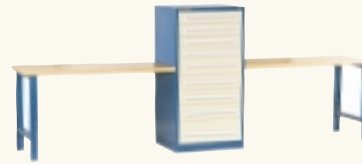

D-6

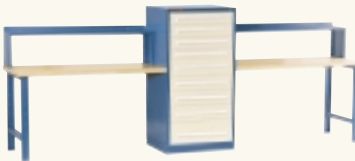

D-7

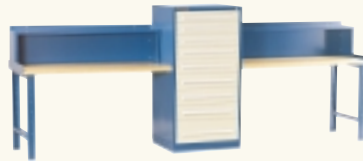

D-8

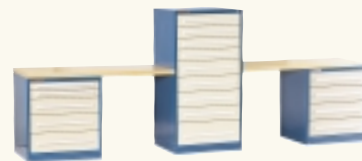

D-9

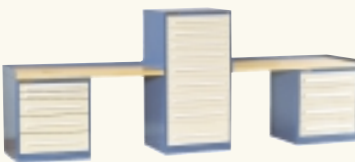

D-10

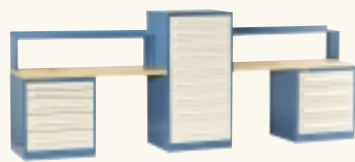

D-11

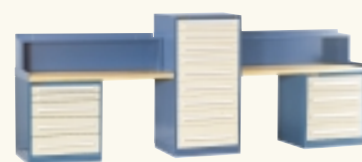

D-12

WORKSTATIONS & BENCHING

SPECIFIC CONFIGURATIONS & STANDARD CABINETS

Standard Cabinets

Choose from 15 drawer sizes and 8 drawer interiors for standard size cabinets. Standard cabinets measure 30 in. (762 mm) wide by 27-3/4 in. (705 mm) deep. Cabinet heights vary from 30 in. (762 mm) to 59 in. (1499 mm). All cabinets below work surface must be same height.

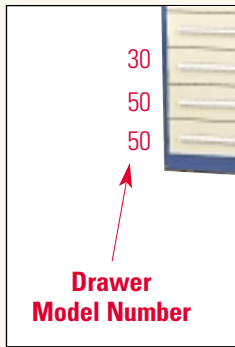
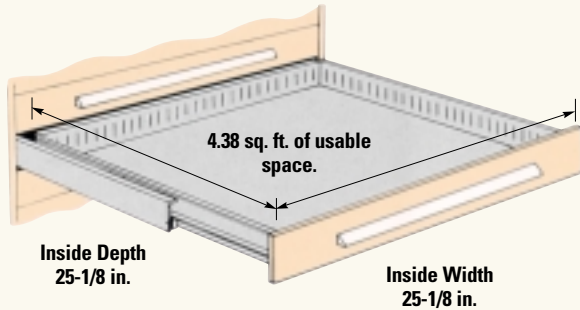

MODEL#	USABLE HEIGHT	
	IN.	(MM)
20	2-1/4 in.	(57 mm)
25	3 in.	(76 mm)
30	3-7/8 in.	(98 mm)
35	4-5/8 in.	(117 mm)
40	5-3/8 in.	(137 mm)
45	6-1/4 in.	(159 mm)
50	7 in.	(178 mm)
55	7-3/4 in.	(197 mm)
60	8-1/2 in.	(216 mm)
65	9-3/8 in.	(240 mm)
70	10-1/8 in.	(257 mm)
75	10-7/8 in.	(276 mm)
80	11-3/4 in.	(292 mm)
85	12-1/2 in.	(318 mm)
90	13-1/4 in.	(337 mm)

Interiors Loading Diagrams (LD)

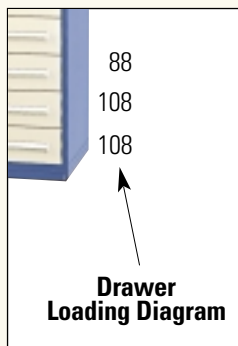

LD48
32 Compartments
2-5/8 in. x 6-1/8 in.
(67 mm x 156 mm)



LD55
36 Compartments
3-1/2 in. x 3-7/8 in.
(89 mm x 98 mm)



LD68
20 Compartments
4-1/4 in. x 6-1/8 in.
(108 mm x 156 mm)



LD108
12 Compartments
7-1/2 in. x 6-1/8 in.
(191 mm x 156 mm)



LD168
8 Compartments
12-1/4 in. x 6-1/8 in.
(311 mm x 156 mm)



LD58
24 Compartments
3-1/2 in. x 6-1/8 in.
(89 mm x 156 mm)



LD88
16 Compartments
5-7/8 in. x 6-1/8 in.
(149 mm x 156 mm)



LD3232
1 Compartment
25-1/8 in. x 25-1/8 in.
(638 mm x 638 mm)

Toll Free Customer Service Number: 1-800-523-9462
Customer Service FAX Number: 1-800-523-9934



30 in. High

Workstation Cabinets:
Drawer and Shelf Door Cabinets



SEP1401
6 Drawers
136 Compartments
Usable Drawer Heights
3 in. (76 mm)
3-7/8 in. (98 mm)



SEP1402
6 Drawers
132 Compartments
Usable Drawer Heights
2-1/4 in. (57 mm)
3 in. (76 mm)
6-1/4 in. (159 mm)



SEP1404
4 Drawers
56 Compartments
Usable Drawer Heights
4-5/8 in. (117 mm)
5-3/8 in. (137 mm)



SEP1405
4 Drawers
68 Compartments
Usable Drawer Heights
2-1/4 in. (57 mm)
3-7/8 in. (98 mm)
4-5/8 in. (117 mm)
10-1/8 in. (257 mm)



SEP1406
3 Drawers
28 Compartments
Usable Drawer Heights
7 in. (178 mm)
7-3/4 in. (197 mm)



SEP1407
2 Drawers
16 Compartments
Usable Drawer Heights
10-7/8 in. (276 mm)
11-3/4 in. (292 mm)

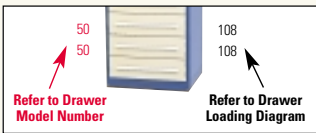

SEP1411
3 Drawers
40 Compartments
Usable Drawer Heights
4-5/8 in. (117 mm)
8-1/2 in. (216 mm)



SD155LH1
(Left Hinge — Shown)
SD155RHI
(Right Hinge)
1 Shelf and Bottom Pan



RP1413
1 Drawer
16 Compartments
1 Shelf and Bottom Pan
Usable Drawer Height
2-1/4 in. (57 mm)



WORKSTATIONS & BENCHING

STANDARD CABINETS



33 in. High

Workstation Cabinets:
Drawer Cabinets



SEP1001
7 Drawers
152 Compartments
Usable Drawer Height
3 in. (76 mm)



SEP1002
7 Drawers
140 Compartments
Usable Drawer Heights
2-1/4 in. (57 mm)
3-7/8 in. (98 mm)
4-5/8 in. (117 mm)



SEP1004
6 Drawers
108 Compartments
Usable Drawer Heights
2-1/4 in. (57 mm)
3 in. (76 mm)
3-7/8 in. (98 mm)
7 in. (178 mm)



SEP1012
5 Drawers
76 Compartments
Usable Drawer Heights
3-7/8 in. (98 mm)
5-3/8 in. (137 mm)
6-1/4 in. (159 mm)



SEP1019
5 Drawers
84 Compartments
Usable Drawer Heights
2-1/4 in. (57 mm)
5-3/8 in. (137 mm)
6-1/4 in. (159 mm)
7 in. (178 mm)



SEP1023
5 Drawers
92 Compartments
Usable Drawer Heights
2-1/4 in. (57 mm)
3 in. (76 mm)
3-7/8 in. (98 mm)
5-3/8 in. (137 mm)
8-1/2 in. (216 mm)



Toll Free Customer Service Number: 1-800-523-9462
Customer Service FAX Number: 1-800-523-9934



33 in. High (Continued)

Workstation Cabinets:
Drawer and Shelf Door Cabinets



SEP1027
5 Drawers
80 Compartments
Usable Drawer Heights
2-1/4 in. (57 mm)
3 in. (76 mm)
7 in. (178 mm)
8-1/2 in. (216 mm)



SEP1031
4 Drawers
56 Compartments
Usable Drawer Heights
5-3/8 in. (137 mm)
6-1/4 in. (159 mm)



SEP1037
4 Drawers
68 Compartments
Usable Drawer Heights
2-1/4 in. (57 mm)
6-1/4 in. (159 mm)
13-1/4 in. (337 mm)



SEP1039
3 Drawers
28 Compartments
Usable Drawer Heights
7-3/4 in. (197 mm)
8-1/2 in. (216 mm)



SEP1043
3 Drawers
36 Compartments
Usable Drawer Heights
6-1/4 in. (159 mm)
8-1/2 in. (216 mm)
10-1/8 in. (257 mm)



SEP1045
2 Drawers
16 Compartments
Usable Drawer Heights
12-1/2 in. (318 mm)
13-1/4 in. (337 mm)

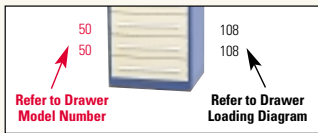

SEP1064
4 Drawers
56 Compartments
Usable Drawer Heights
3-7/8 in. (98 mm)
6-1/4 in. (159 mm)
7 in. (178 mm)



SEP1071
3 Drawers
36 Compartments
Usable Drawer Heights
5-3/8 in. (137 mm)
6-1/4 in. (159 mm)
13-1/4 in. (337 mm)



SD175LH1
(Left Hinge — Shown)
SD175RH1
(Right Hinge)
1 Shelf and Bottom Pan



RP1078
2 Drawers
52 Compartments
1 Shelf and Bottom Pan
Usable Drawer Height
2-1/4 in. (57 mm)



RP1080
1 Drawer
16 Compartments
1 Shelf and Bottom Pan
Usable Drawer Height
5-3/8 in. (137 mm)



RP1082
1 Drawer
32 Compartments
1 Shelf and Bottom Pan
Usable Drawer Height
2-1/4 in. (57 mm)

WORKSTATIONS & BENCHING

STANDARD CABINETS



59 in. High

**Workstation Cabinets:
Drawer and Shelf Door Cabinets**

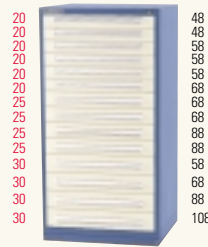

SEP3026
14 Drawers
300 Compartments
Usable Drawer Heights
2-1/4 in. (57 mm)
3 in. (76 mm)
3-7/8 in. (98 mm)



SEP3126
10 Drawers
164 Compartments
Usable Drawer Heights
2-1/4 in. (57 mm)
3-7/8 in. (98 mm)
5-3/8 in. (137 mm)
8-1/2 in. (216 mm)

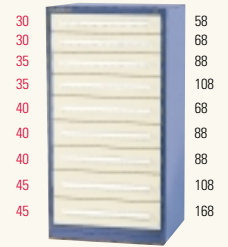

SEP3140
9 Drawers
144 Compartments
Usable Drawer Heights
3-7/8 in. (98 mm)
4-5/8 in. (117 mm)
5-3/8 in. (137 mm)
6-1/4 in. (159 mm)

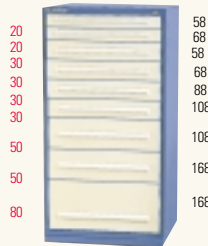

SEP3155
9 Drawers
144 Compartments
Usable Drawer Heights
2-1/4 in. (57 mm)
3-7/8 in. (98 mm)
7 in. (178 mm)
11-3/4 in. (292 mm)



SEP3157
8 Drawers
112 Compartments
Usable Drawer Heights
5-3/8 in. (137 mm)
6-1/4 in. (159 mm)

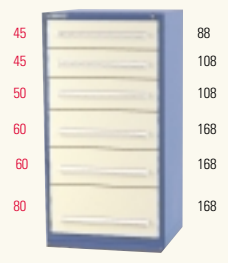

SEP3203
6 Drawers
64 Compartments
Usable Drawer Heights
6-1/4 in. (159 mm)
7 in. (178 mm)
8-1/2 in. (216 mm)
11-3/4 in. (292 mm)

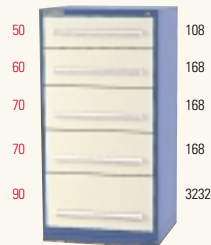
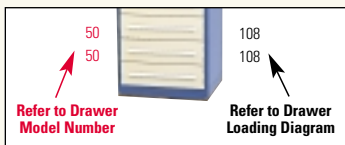

SEP3214
5 Drawers
37 Compartments
Usable Drawer Heights
7 in. (178 mm)
8-1/2 in. (216 mm)
10-1/8 in. (257 mm)
13-1/4 in. (337 mm)



SD340L2A
(Left Hinge — Shown)
SD340R2A
(Right Hinge)
2 Shelves and Bottom Pan,
No Door S340

Work Surfaces Workstation Top Covers

Available in hardwood, plastic, shop top, steel plate, stainless steel over laminate, and static dissipative surfaces. Choose the right work surface for your application from the table below.



DESCRIPTION, IN. (MM)	CONSTRUCTION	APPLICATION	SPANS,* IN. (MM)
30 in. (762 mm) Deep (Front to Back) Work Surfaces			
1-1/2 in. (38 mm) Thick, Plastic Top	Laminate top over particle board core	Light duty benching applications	72 in. (1829 mm)
1-1/2 in. (38 mm) Thick, Radius Edge Plastic Top	Laminate top over particle board core	Light duty benching applications	72 in. (1829 mm)
1-3/4 in. (44 mm) Thick, Shop Top	High density resin core with particle board surface	Heavy duty workbench applications	72 in. (1829 mm)
1-3/4 in. (44 mm) Thick, Steel Top	Painted steel top with enclosed ends	Heavy duty workbench	96 in. (2438 mm)
1-3/4 in. (44 mm) Thick, Hardwood Top	Solid, hardwood	Heavy duty	96 in. (2438 mm)
1-1/4 in. (32 mm) Thick, Static Dissipative Top	Laminate over particle board	StaticGard applications	60 in. (1524 mm)
27-3/4 in. (705 mm) Deep Cabinet Covers			
7/8 in. (22 mm) Thick, Plastic Top	Laminate over particle	Cabinet cover	none
7/8 in. (22 mm) Stainless Steel Surface for Top	Fits over particle board or cabinet	Cabinet cover	none
1/4 in. (6 mm) Steel Plate Top	Fits over any surface, painted	Cabinet cover, heavy duty	none
1/8 in. (3 mm) Steel Plate Top	Fits over any surface, painted	Cabinet cover, heavy duty	none
Other Tops			
1-3/4 in. (44 mm) Thick, 36 in. (914 mm) Deep, Full Radius, Dissipative Top	Laminate over particle board	StaticGard applications	60 in. (1524 mm)
30 in. (762 mm) Deep Stainless Steel Surface to Fit Over Top	Formed stainless steel	Cabinet cover	none

* Light duty and StaticGard spans are based on max. 200 lb (91 kg) concentrated loads. All other spans are based on 400 lb (181 kg) concentrated loads.

WORKSTATIONS & BENCHING

WORK SURFACES

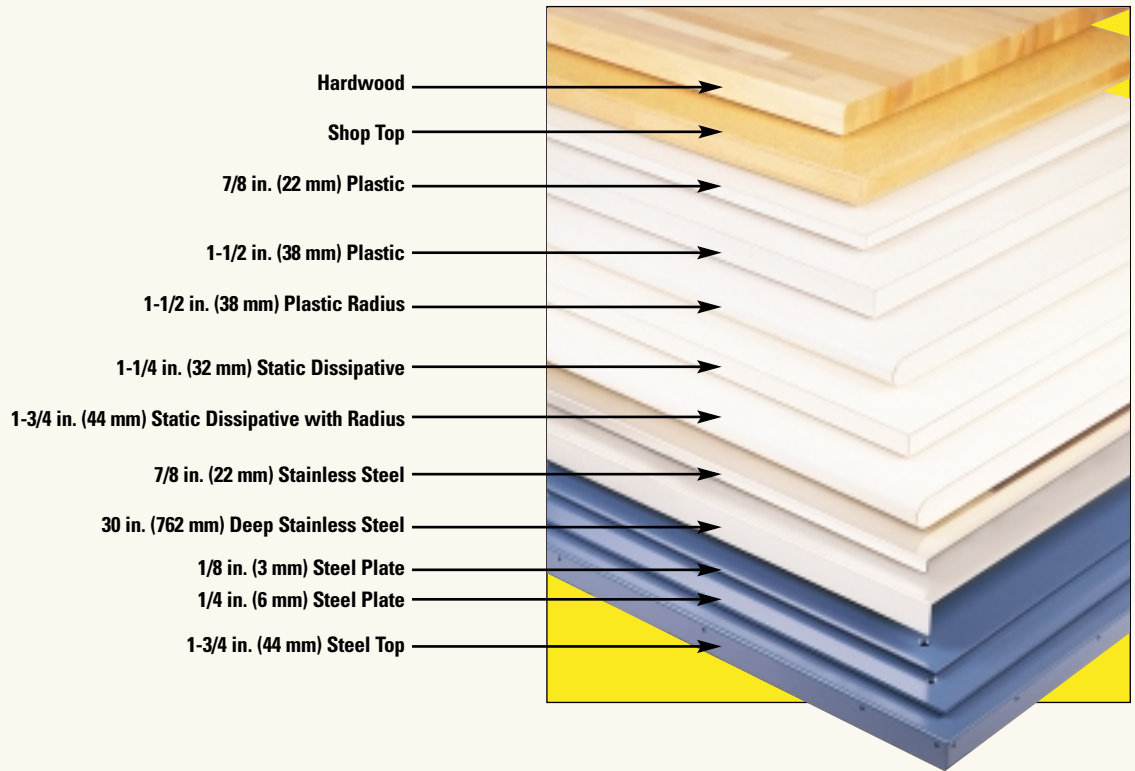

MODEL #S.—TOP LENGTHS, IN. (MM)

30 IN. (762 MM)	45 IN. (1143 MM)	60 IN. (1524 MM)	72 IN. (1829 MM)	84 IN. (2134 MM)	90 IN. (2286 MM)	96 IN. (2438 MM)	120 IN. (3048 MM)
--------------------	---------------------	---------------------	---------------------	---------------------	---------------------	---------------------	----------------------

PL30	PL45	PL60	PL72	PL84	PL90	PL96	
		PLR60	PLR72	PLR84	PLR90	PLR96	
WT30	WT45	WT60	WT72	WT84	WT90	WT96	
ST30	ST45	ST60	ST72	ST84	ST90	ST96	
HT30	HT45	HT60	HT72	HT84	HT90	HT96	HT120
		SG60301	SG72301	SG84301	SG90301	SG96301	
MLPT01		MLPT02			MLPT03		MLPT04
SIS30	SIS45	SIS60	SIS72	SIS84	SIS90	SIS96	SIS120
SPT014		SPT024					
SPT018		SPT028					
		SGWS60361	SGWS72361	SGWS84361	SGWS90361	SGWS96361	
SIS30M	SIS45M	SIS60M	SIS72M	SIS84M	SIS90M	SIS96M	

Open Bench Legs

- Formed steel leg units predrilled for fastening.
- Manufactured with knockouts for standard two-outlet electrical fixtures. (Fixtures and electrical work are not available from Stanley Vidmar.)

Panel Bench Legs

- Combination of open bench legs and panels.

Side Panels

- Designed to fit exactly into open bench leg and bolt easily into place.

Back Stops

- Flat steel panels used to enclose lower 3 in. (76 mm) of rear of riser shelf.
- Predrilled for fastening to riser shelf and bench top. (Same basic design as back panel, except only 3-3/4 in. [92 mm] high.)

End Stops

- Flat steel panels with rear portions formed and pierced for attachment to backstops and/or riser shelves.
- Supplied in a pair for left and right ends of bench unit.

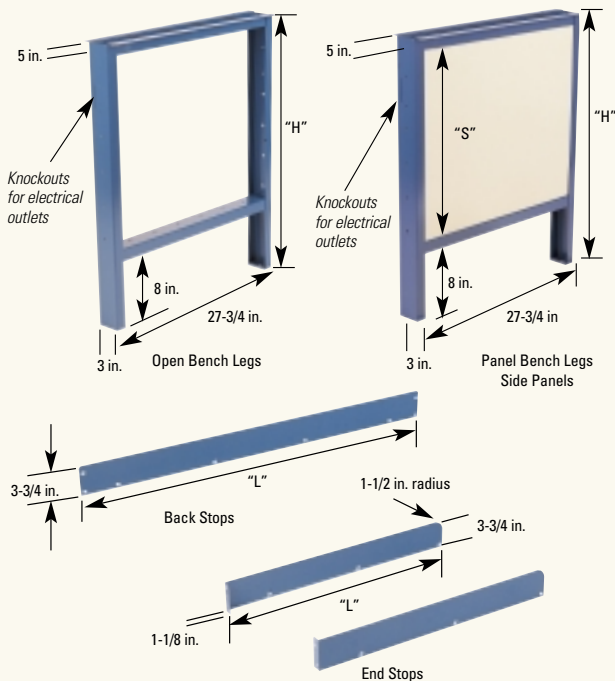

Open Bench Legs

MODEL#	DESCRIPTION	HEIGHT	
		IN.	(MM)
BL1351	For 135 Cab. with Pallet Feet	26.76 in.	(680 mm)
BL1352	For 135 Cab. with HNF	24.60 in.	(625 mm)
BL1353	For 135 Cab. with RB	29.76 in.	(756 mm)
BL1354	For 135 Cab. with RB and HNF	27.60 in.	(701 mm)
BL1355	For 135 Cab. with Channel Base	25.35 in.	(644 mm)
BL1551	For 155 Cab. with Pallet Feet	29.91 in.	(760 mm)
BL1552	For 155 Cab. with HNF	27.78 in.	(705 mm)
BL1553	For 155 Cab. with RB	32.91 in.	(836 mm)
BL1554	For 155 Cab. with RB and HNF	30.75 in.	(781 mm)
BL1555	For 155 Cab. with Channel Base	28.53 in.	(724 mm)
BL1751	For 175 Cab. with Pallet Feet	33.06 in.	(840 mm)
BL1752	For 175 Cab. with HNF	30.93 in.	(785 mm)
BL1753	For 175 Cab. with RB	36.06 in.	(916 mm)
BL1754	For 175 Cab. with RB and HNF	33.90 in.	(861 mm)
BL1755	For 175 Cab. with Channel Base	31.65 in.	(804 mm)
BL2001	For 200 Cab. with Pallet Feet	37.00 in.	(940 mm)
BL2002	For 200 Cab. with HNF	34.87 in.	(885 mm)
BL2003	For 200 Cab. with RB	40.00 in.	(1016 mm)
BL2004	For 200 Cab. with RB and HNF	37.84 in.	(961 mm)
BL2005	For 200 Cab. with Channel Base	35.59 in.	(904 mm)
BL2451	For 245 Cab. with Pallet Feet	44.08 in.	(1119 mm)
BL2452	For 245 Cab. with HNF	41.92 in.	(1065 mm)
BL2453	For 245 Cab. with RB	47.08 in.	(1195 mm)
BL2454	For 245 Cab. with RB and HNF	44.92 in.	(1141 mm)
BL2455	For 245 Cab. with Channel Base	42.67 in.	(1084 mm)

Panel Bench Legs

MODEL#	DESCRIPTION	HEIGHT	
		IN.	(MM)
PBL1351	For 135 Cab. with Pallet Feet	26.76 in.	(680 mm)
PBL1353	For 135 Cab. with RB	29.76 in.	(756 mm)
PBL1551	For 155 Cab. with Pallet Feet	29.91 in.	(760 mm)
PBL1553	For 155 Cab. with RB	32.91 in.	(836 mm)
PBL1751	For 175 Cab. with Pallet Feet	33.06 in.	(840 mm)
PBL1753	For 175 Cab. with RB	36.06 in.	(916 mm)
PBL2001	For 200 Cab. with Pallet Feet	37.00 in.	(940 mm)
PBL2003	For 200 Cab. with RB	40.00 in.	(1016 mm)
PBL2451	For 245 Cab. with Pallet Feet	44.08 in.	(1119 mm)
PBL2453	For 245 Cab. with RB	47.08 in.	(1195 mm)

Side Panels

MODEL#	DESCRIPTION	HEIGHT	
		IN.	(MM)
BLSP16	For use with BL1351	15.94 in.	(405 mm)
BLSP19	For use with BL1353 and BL1551	18.94 in.	(481 mm)
BLSP22	For use with BL1553 and BL1751	22.09 in.	(561 mm)
BLSP25	For use with BL1753	25.24 in.	(641 mm)
BLSP28	For use with BL2003	29.18 in.	(741 mm)
BLSP33	For use with BL2451	33.26 in.	(845 mm)
BLSP36	For use with BL2453	36.26 in.	(921 mm)

Back Stops

MODEL#	LENGTH	
	IN.	(MM)
BS330	30 in.	(762 mm)
BS342	42 in.	(1067 mm)
BS345	45 in.	(1143 mm)
BS348	48 in.	(1219 mm)
BS360	60 in.	(1524 mm)
BS372	72 in.	(1829 mm)
BS384	84 in.	(2134 mm)
BS396	96 in.	(2438 mm)
BS3120	120 in.	(3048 mm)

End Stops

MODEL#	LENGTH	
	IN.	(MM)
ES328	27-3/4 in.	(705 mm)
ES330	30 in.	(762 mm)
ES336	36 in.	(914 mm)

WORKSTATIONS & BENCHING

ACCESSORIES

Bench Riser Shelves/ Corner Riser Shelves (A,B)

- Ideal for getting tools, test and other equipment off work surface.
- 12 in. (305 mm) deep.
- Available in fixed 14 in. (356 mm) height or adjustable height from 12 to 22 in. (305 to 559 mm).

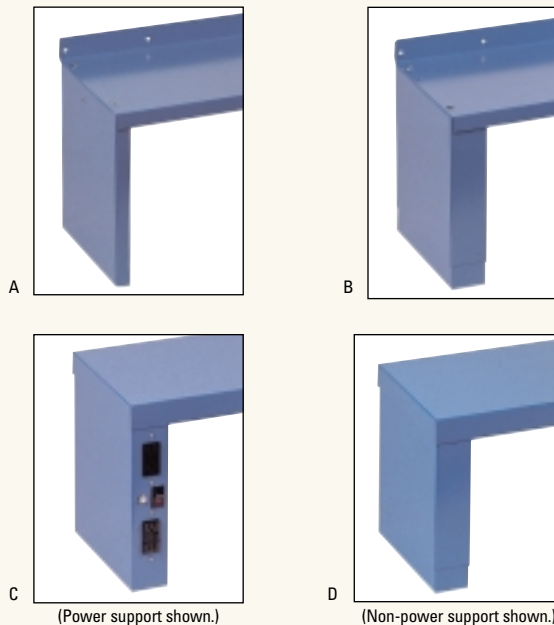

Workstation Riser Shelves/ Corner Riser Shelves (C,D)

- Available in fixed 15 in. (381 mm) height or adjustable height from 12 to 22 in. (305 to 559 mm).
- Power (110V) can be supplied to workstation through uprights, shelves, or both. (Options below.)
- 12 in. (305 mm) deep.

Fixed Height Bench Riser Shelves/Corner Riser Shelves (A)

MODEL#	FIXED HEIGHT	SHELF MATERIAL	POWER	CORNER RISER MODEL#
*BFS30, 36, 42, 48, 54, 60, 72, 84, 96	12 in. x 14 in. (305 mm x 356 mm)	Steel	See Electrical Outlet Strip Chart	CBFS30
*BFH30, 36, 42, 48, 54, 60, 72, 84, 96	12 in. x 14 in. (305 mm x 356 mm)	Ash Hardwood (add 1-1/4 in. {32 mm} to height)		CBFH30

*Note: To order back panels (fixed risers only), use BPBFS 30/36/42/48/54/60/72/84/96 for steel and hardwood shelves.

Adjustable Height Bench Riser Shelves/Corner Riser Shelves (B)

MODEL#	ADJUSTABLE HEIGHT	SHELF MATERIAL	POWER	CORNER RISER MODEL#
*BAS30, 36, 42, 48, 54, 60, 72, 84, 96 See WAH below	12 in. x 12 in.-22 in. (305 mm x 305 mm-559 mm)	Steel Hardwood	See Electrical Outlet Strip Chart	CBAS30 See CWAH30 below

*Note: To order back panels (fixed risers only), use BPBFS 30/36/42/48/54/60/72/84/96 for steel and hardwood shelves.

Fixed Height Workstation Riser Shelves/Corner Riser Shelves (C)

MODEL#	FIXED HEIGHT	SHELF MATERIAL	POWER	CORNER RISER MODEL#
*WFS30, 36, 42, 48, 54, 60, 72, 84, 96	12 in. x 15 in. (305 mm x 381 mm)	Steel	None	CWFS30
*WFS30P, 36P, 42P, 48P, 54P, 60P, 72P, 84P, 96P	12 in. x 15 in. (305 mm x 381 mm)	Steel	Shelf and supports (with GFCI)	CWFS30
*WFH30, 36, 42, 48, 54, 60, 72, 84, 96	12 in. x 15 in. (305 mm x 381 mm)	Hardwood	None	CWFH30
*WFH30P, 36P, 42P, 48P, 54P, 60P, 72P, 84P, 96P	12 in. x 15 in. (305 mm x 381 mm)	Hardwood	Supports only (with GFCI)	CWFH30

*Note: To order back panels (fixed risers only), use BPWFS 30/36/42/48/54/60/72/84/96 for steel surfaces, and BPWFH 30/36/42/48/54/60/72/84/96 for hardwood surfaces.

Adjustable Height Workstation Riser Shelves/Corner Riser Shelves (D)

MODEL#	ADJUSTABLE HEIGHT	SHELF MATERIAL	POWER	CORNER RISER MODEL#
*WAS30, 36, 42, 48, 54, 60, 72, 84, 96	12 in. x 12 in.-22 in. (305 mm x 305 mm-559 mm)	Steel	None	CWAS30
*WAS30P, 36P, 42P, 48P, 54P, 60P, 72P, 84P, 96P	12 in. x 12 in.-22 in. (305 mm x 305 mm-559 mm)	Steel	Shelf only (with GFCI)	CWAS30
*WAH30, 36, 42, 48, 54, 60, 72, 84, 96	12 in. x 12 in.-22 in. (305 mm x 305 mm-559 mm)	Hardwood (add 1/4 in. {6 mm} to height)	See Electrical Outlet Strip Chart If Power Is Required	CWAH30

*Note: To order back panels (fixed risers only), use BPWFS 30/36/42/48/54/60/72/84/96 for steel surfaces, and BPWFH 30/36/42/48/54/60/72/84/96 for hardwood surfaces.

Toll Free Customer Service Number: 1-800-523-9462
Customer Service FAX Number: 1-800-523-9934

Back Panels (A,B)

- Formed steel panel used to completely enclose rear of riser shelf.
- Predrilled for fastening to riser shelf and bench top.
- Support braces supplied with riser shelf are not used when optional back panel is utilized.

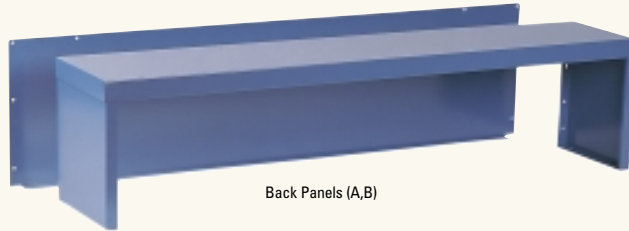

Back Panels (A,B)

Stringer, Footrest and Footrest Shelves

- Used between cabinets or between bench leg and cabinet.
- Stringers and bench legs are predrilled.



Stringer

Footrest

Footrest/Shelf

Back Panels: Fixed Bench Risers (Use with BFS Risers.) (A)

MODEL#	DESCRIPTION	LENGTH	
		IN.	(MM)
BPBFS30	Fixed steel	30 in.	(762 mm)
BPBFS36	Fixed steel	36 in.	(914 mm)
BPBFS42	Fixed steel	42 in.	(1067 mm)
BPBFS48	Fixed steel	48 in.	(1219 mm)
BPBFS54	Fixed steel	54 in.	(1372 mm)
BPBFS60	Fixed steel	60 in.	(1524 mm)
BPBFS72	Fixed steel	72 in.	(1829 mm)
BPBFS84	Fixed steel	84 in.	(2134 mm)
BPBFS96	Fixed steel	96 in.	(2438 mm)
BPBFS30	Fixed Hardwood	30 in.	(762 mm)
BPBFS36	Fixed Hardwood	36 in.	(914 mm)
BPBFS42	Fixed Hardwood	42 in.	(1067 mm)
BPBFS48	Fixed Hardwood	48 in.	(1219 mm)
BPBFS54	Fixed Hardwood	54 in.	(1372 mm)
BPBFS60	Fixed Hardwood	60 in.	(1524 mm)
BPBFS72	Fixed Hardwood	72 in.	(1829 mm)
BPBFS84	Fixed Hardwood	84 in.	(2134 mm)
BPBFS96	Fixed Hardwood	96 in.	(2438 mm)

Back Panels: Workstation Risers (B)

MODEL#	DESCRIPTION	LENGTH	
		IN.	(MM)
BPWFS30	Fixed steel	30 in.	(762 mm)
BPWFS36	Fixed steel	36 in.	(914 mm)
BPWFS42	Fixed steel	42 in.	(1067 mm)
BPWFS48	Fixed steel	48 in.	(1219 mm)
BPWFS54	Fixed steel	54 in.	(1372 mm)
BPWFS60	Fixed steel	60 in.	(1524 mm)
BPWFS72	Fixed steel	72 in.	(1829 mm)
BPWFS84	Fixed steel	84 in.	(2134 mm)
BPWFS96	Fixed steel	96 in.	(2438 mm)
BPWFM30	Fixed Hardwood	30 in.	(762 mm)
BPWFM36	Fixed Hardwood	36 in.	(914 mm)
BPWFM42	Fixed Hardwood	42 in.	(1067 mm)
BPWFM48	Fixed Hardwood	48 in.	(1219 mm)
BPWFM54	Fixed Hardwood	54 in.	(1372 mm)
BPWFM60	Fixed Hardwood	60 in.	(1524 mm)
BPWFM72	Fixed Hardwood	72 in.	(1829 mm)
BPWFM84	Fixed Hardwood	84 in.	(2134 mm)
BPWFM96	Fixed Hardwood	96 in.	(2438 mm)

Stringer (Use with WFS Risers.)

MODEL#	DESCRIPTION	WORKSTATION TOP SIZES IN. (MM)					
		60 IN. (1524 MM)	72 IN. (1829 MM)	84 IN. (2134 MM)	90 IN. (2286 MM)	96 IN. (2438 MM)	120 IN. (3048 MM)
STCCXXX	Std. Cabinet to Std. Cabinet	-	-	024	030	036	060
STBCXXX	Bench Leg to Std. Cabinet	030	042	054	060	066	090
STCCXXX	Sm. Version Cab. to Sm. Version Cab.	-	027	039	045	051	075
STBCXXX	Bench Leg to Sm. Version Cab.	037	049	061	067	073	097
STCCXXX	Std. Cabinet to Sm. Version Cab.	-	019	031	037	043	067
BLFRXX	Bench Leg to Bench Leg	60	72	84	90	96	120

Not Available on Corner Workstations

Footrest

MODEL#	DESCRIPTION	WORKSTATION TOP SIZES IN. (MM)					
		60 IN. (1524 MM)	72 IN. (1829 MM)	84 IN. (2134 MM)	90 IN. (2286 MM)	96 IN. (2438 MM)	120 IN. (3048 MM)
FRCCXXX	Std. Cabinet to Std. Cabinet	-	-	024	030	036	060
FRBCXXX	Bench Leg to Std. Cabinet	030	042	054	060	066	090
FRCCXXX	Sm. Version Cab. to Sm. Version Cab.	-	027	039	045	051	075
FRBCXXX	Bench Leg to Sm. Version Cab.	037	049	061	067	073	097
FRCCXXX	Std. Cabinet to Sm. Version Cab.	-	019	031	037	043	067
BLFRXX	Bench Leg to Bench Leg	60	72	84	90	96	120

Not Available on Corner Workstations

Footrest/Shelf

MODEL#	DESCRIPTION	WORKSTATION TOP SIZES IN. (MM)					
		60 IN. (1524 MM)	72 IN. (1829 MM)	84 IN. (2134 MM)	90 IN. (2286 MM)	96 IN. (2438 MM)	120 IN. (3048 MM)
SHCCXXX	Std. Cabinet to Std. Cabinet	-	-	024	030	036	060
SHBCXXX	Bench Leg to Std. Cabinet	030	042	054	060	066	090
SHCCXXX	Sm. Version Cab. to Sm. Version Cab.	-	027	039	045	051	075
SHBCXXX	Bench Leg to Sm. Version Cab.	037	049	061	067	073	097
SHCCXXX	Std. Cabinet to Sm. Version Cab.	-	019	031	037	043	067
BLSXX	Bench Leg to Bench Leg	60	72	84	90	96	120

Not Available on Corner Workstations

WORKSTATIONS & BENCHING

ACCESSORIES

Under the Bench Pre-Configured Cabinets

(Not Shown)
Available in six footprints:

1. Standard - 30 in. W x 27-3/4 in. D
(UB0040, UB0060, UB0090, UB0110)
 2. Shallow Depth - 30 in. W x 21-3/8 in. D
(LWUB0040, LWUB0060, LWUB00110)
 3. Small Version - 22-1/2 in. W x 27-3/4 in. D
(SVUB0040, SVUB0060, SVUB0090, SVUB0110)
 4. Extra Wide - 45 in. W x 27-3/4 in. D
(XWUB0040, XWUB0060, XWUB0090)
 5. Extra Wide Shallow Depth - 45 in. W x 21-3/8 in. D
(XLUB0040, XLUB0090)
 6. Double Wide - 60 in. W x 27-3/4 in. D
(DWUB0040, DWUB0060, DWUB0090)
- Ideal for suspending from hardwood work surfaces.
 - Provides same durable storage capabilities as with full-size Vidmar cabinets.
 - UB cabinets allow for same drawer modularity as conventional cabinets. (Total drawer "points" must equal cabinet model number.)

Under the Bench Pre-Configured Cabinets

MODEL#	# & TYPE OF DRAWERS	CABINET HEIGHT	
		IN.	(MM)
UB40202	2 of #20	9-3/4 in.	(248 mm)
UB40401	1 of #40	9-3/4 in.	(248 mm)
UB60203	3 of #20	12-7/8 in.	(372 mm)
UB60302	2 of #30	12-7/8 in.	(372 mm)
UB60201401	1 of #20, 1 of #40	12-7/8 in.	(372 mm)
UB60601	1 of #60	12-7/8 in.	(372 mm)

AVAILABLE IN :	HOUSING MODEL	HEIGHT
	40	9-3/4 in. (248 mm)
	60	12-7/8 in. (372 mm)
	90	17-5/8 in. (448 mm)
	110	20-3/4 in. (527 mm)



Bookcase Riser

Bookcase Riser

- Specially made to support bookcases

Splice Kits

Model # SP 28 in. (711 mm) long.

- Includes predrilled metal plate and attaching hardware.
- Used when joining two tops to form a corner workstation.

Electrical Outlet Strips and Lights

- Attach to the face or rear of a bench riser, a work surface shelf, or to a backstop located at the rear of a work surface.
- Part numbers ending in P are available in silver gray, enamel finish, prewired with plug; part numbers not ending in P are beige (with wiring instructions.)
- Prewired strips are less than 2 in. (51 mm) square, have a 15 amp circuit breaker, a snap-clip mounting system, and are UL listed and CSA Certified.*
- Fluorescent lights are available in lengths of 18 in., 36 in. and 48 in.

Notes: Power to workstation should be wired through GFCI receptacle. Factory installation not available for electrical outlet strips.

* Bench accessories are not predrilled for electrical outlet strips.

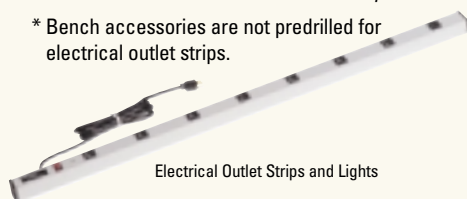

Electrical Outlet Strips and Lights

Bookcase Riser

MODEL#	DESCRIPTION	HEIGHT		LENGTH		APPLICATION
		IN.	(MM)	IN.	(MM)	
BKR3014	Riser	14 in.	(356 mm)	30 in.	(762 mm)	One Standard Width Bookcase
BKR3021	Riser	21 in.	(533 mm)	30 in.	(762 mm)	One Standard Width Bookcase
BKR3024	Riser	24 in.	(610 mm)	30 in.	(762 mm)	One Standard Width Bookcase
BKR4514	Riser	14 in.	(356 mm)	45 in.	(1143 mm)	One Extra Wide Bookcase
BKR4521	Riser	21 in.	(533 mm)	45 in.	(1143 mm)	One Extra Wide Bookcase
BKR4524	Riser	24 in.	(610 mm)	45 in.	(1143 mm)	One Extra Wide Bookcase
BKR6014	Riser	14 in.	(356 mm)	60 in.	(1524 mm)	One Double Wide or Two Standard Bookcases
BKR6021	Riser	21 in.	(533 mm)	60 in.	(1524 mm)	One Double Wide or Two Standard Bookcases
BKR6024	Riser	24 in.	(610 mm)	60 in.	(1524 mm)	One Double Wide or Two Standard Bookcases
BKR9014	Riser	14 in.	(356 mm)	90 in.	(2286 mm)	Three Standard, Two Extra Wide, or One Double Wide and One Standard Bookcase
BKR9021	Riser	21 in.	(533 mm)	90 in.	(2286 mm)	Three Standard, Two Extra Wide, or One Double Wide and One Standard Bookcase
BKR9024	Riser	24 in.	(610 mm)	90 in.	(2286 mm)	Three Standard, Two Extra Wide, or One Double Wide and One Standard Bookcase

Electrical Outlet Strips and Lights

MODEL#	# OF OUTLETS	LENGTH	
		IN.	(MM)
Electrical Outlet Strips			
EOS09P	4	9 in.	(229 mm)
EOS24P	8	24 in.	(610 mm)
EOS48P	8	48 in.	(1219 mm)
EOS72P	9	72 in.	(1829 mm)
EOS36	6	36 in.	(914 mm)
EOS60	5	60 in.	(1524 mm)
EOS72	6	72 in.	(1829 mm)
Lights			
FL01807200		18 in.	(457 mm)
FL03607200		36 in.	(914 mm)
FL04807200		48 in.	(1219 mm)

Toll Free Customer Service Number: 1-800-523-9462
Customer Service FAX Number: 1-800-523-9934

Corner Desk

- Provides remote working space and extra storage space for manuals and records.
- Designed to complete a corner turn when cabinets are arranged in an "L" or square formation.
- Desks are 44 in. (1118 mm) high and occupy the space of two standard cabinets, and one corner spacer.
- Features include fluorescent light with switch, pencil/accessory drawer, and bookcase with two shelves. (See bookcase section on next page for additional bookcase options.)



Corner Desk



Straight Desk

Straight Desk

- Provides writing surface and supervisory work areas.
- Available in 30 in. (762 mm) and 60 in. (1524 mm) widths and 44 in. (1118 mm) height.
- Features include fluorescent light with switch, pencil/accessory drawer, and laminated writing surface with knockouts for wiring access.

Corner Desk

MODEL#	DESCRIPTION
CDA58R	Right-hand corner desk
CDA58L	Left-hand corner desk
MLPT58R	Laminated Top for right-hand desk
MLPT58L	Laminated Top for left-hand desk

Straight Desk

MODEL#	DESCRIPTION
SDA30	30 in. (762 mm) Straight Desk
SDA60	60 in. (1524 mm) Straight Desk
MLPT30	Laminated Top for upper shelf, 30 in. (762 mm)
MLPT60	Laminated Top for upper shelf, 60 in. (1524 mm)

Slope Top Desk

- Model # DST30 (For Standard Cabinet)
- Model # DST45 (For Extra Wide Cabinet)
- Model # DST60 (For Double Wide Cabinet)

- Designed for use where report or record-keeping space is limited.
- Fits on top of standard size cabinet.
- Equipped with pencil holder and clipboard clasp.
- Hinged at rear, desk top opens to provide additional storage space beneath writing surface.
- Lid support included to hold writing surface in open position.



Slope Top Desk



Pencil Drawer

Pencil Drawer

Model # PD2.

- To be used with straight desk, corner desk, or any writing surface.
- Attachment hardware included.

Recessed Bases

- Provide additional toe space at work or issue areas. 3 in. (76 mm) high.



Recessed Bases



Kick Plates

Kick Plates

- Protect outside floor level surfaces of a cabinet.
- Kick plates are stainless steel, 7 in. (178 mm) high.
- Mounted directly to the cabinet with hardware provided.
- Ideal for parts issue or high-traffic areas.

Recessed Bases

MODEL#	DESCRIPTION
RB1	One Standard
RB2	Two Standard or One Double Wide
LWRB1	One Shallow Depth
SVRB1	One Small Version
SVRB2	Two Small Versions
XWRB1	One Extra Wide or Two Small Versions
XLRB1	One Extra Wide Shallow Depth
DWRB1	One Double Wide

Kick Plates

MODEL#	DESCRIPTION
KP1	One Standard or Shallow Depth
KP2	Two Standard, Shallow Depth, Double Wide
KP6C	Corner Desk
XWKP1	One Extra Wide or Extra Wide Shallow Depth
SVKP1	One Small Version

WORKSTATIONS & BENCHING

ACCESSORIES

Bookcase

- Standard bookcase is 30 in. (762 mm) wide — the dimensions of a standard cabinet — and 14 in. (356 mm) deep (See chart.)
- Bookcases are also available in 45" (1143 mm) and 60" (1524 mm) widths.
- See chart for bookcase options.



Bookcase

Lock for Hinged Doors

Model # **SDLBKAXX**

(Replace XX with desired height:

17 in. (432 mm), 27 in. (684 mm), 30 in. (762 mm), 33 in. (838 mm), 37 in. (940 mm) and 44 in. (1118 mm).)

Sling Pick-up Feature

- The sling pick-up feature consists of four threaded steel blocks welded to columns inside the cabinet.
- Blocks accept four eye bolts (supplied) so that cabinet can be lifted fully loaded (6800 lbs).
- Cabinets should be ordered with lock-in/lock-out latches and be banded when moved.

Four-Way Pallet Base

- Allows forklift entry from all sides of cabinet.
- Cabinets should be banded when moved.

Corner Spacer Kits

- Spacer allows any cabinet to turn a corner.
- Available in 33 in. (838 mm), 37 in. (940 mm), 44 in. (1118 mm) counter height and 59 in. (1499 mm) eye level height.

Bookcase

MODEL#*	DESCRIPTION	HEIGHT	# OF SHELVES
BKA44	Standard – 30 in. wide x 14 in. deep	44 in.	2
BKA37	Standard – 30 in. wide x 14 in. deep	37 in.	1
BKA33	Standard – 30 in. wide x 14 in. deep	33 in.	1
BKA30	Standard – 30 in. wide x 14 in. deep	30 in.	1
BKA27	Standard – 30 in. wide x 14 in. deep	27 in.	1
BKA17	Standard – 30 in. wide x 14 in. deep	17 in.	None

*Add prefix of "XW" for 45" wide bookcase or "DW" for 60" wide bookcase (i.e., XWBKA44: etc.)

Bookcase Options

MODEL#	DESCRIPTION	BATTENS	DOUBLE HINGED STEEL DOORS	BYPASSING CLEAR PLASTIC	BYPASSING STEEL
BKAXX*	Standard	BT300	SDBKAXX	PSDBKAXX	SSDBKAXX
XWBKAXX*	Extra Wide	BTXW300	N/A	N/A	N/A
DWBKAXX*	Double Wide	BTDW300	N/A	N/A	N/A
BS30	Bookcase Shelf – 30"	—	—	—	—
BS45	Bookcase Shelf – 45"	—	—	—	—
BS60	Bookcase Shelf – 60"	—	—	—	—
MLPT30	Laminated Top – 30"	—	—	—	—
MLPT45	Laminated Top – 45"	—	—	—	—
MLPT60	Laminated Top – 60"	—	—	—	—

*Substitute height (44, 37, 33, 30, 27, 17) for "XX" in model number.



Sling Pick-Up Features



Four-Way Pallet Base

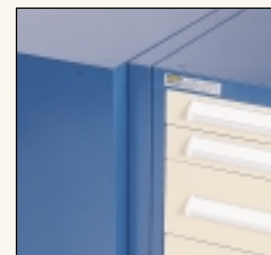

Corner Space Kits

Sling Pick-Up Features

MODEL#	FOR USE WITH HOUSINGS
SPUST	Standard
SPUSV	Small Version
SPULW	Shallow Depth
SPUXW	Extra Wide
SPUDW	Double Wide
SPUXL	Extra Wide Shallow Depth
SPUDL	Double Wide Shallow Depth
SPUSL	Small Version Shallow Depth

Four-way Pallet Base

MODEL#	FOR USE WITH HOUSINGS
PB4ST	Standard
PB4XW	Extra Wide
PB4DW	Double Wide
PB4C	Covers (Two per set)
PB4XL	Extra Wide Shallow Depth
PB4SV	Small Version
PB4LW	Shallow Depth

Corner Space Kits

MODEL#	DESCRIPTION
CCBS175	33 in. (838 mm) corner cabinet
CCBS200	37 in. (940 mm) corner cabinet
CCBS245	44 in. (1118 mm) corner cabinet
CCBS340	59 in. (1499 mm) corner cabinet

Toll Free Customer Service Number: 1-800-523-9462
Customer Service FAX Number: 1-800-523-9934

StaticGard™ Workstations

The StaticGard™ series is a full range of ESD-protective equipment that, as part of your overall static control program, helps create a static-safe work environment. The entire series is designed to provide static dissipative control as determined by the ESD Association Standards, protecting against static damage both at and below the work surface. All workstations have a static-dissipative top with a common grounding point for equipment and personnel, plus wrist strap.

StaticGard™ Maintenance Workstation

Model No. EMW-1

- 5-drawer cabinet (176 adjustable compartments) plus 9-drawer cabinet (172 adjustable compartments).
- Powered, fixed shelf: 18 in. high (clear height) x 18 in. deep (457 mm x 457 mm),
- Prewired with 6 duplex receptacles connected through a GFCI (ground fault circuit interrupt) receptacle.
- Lighted on/off switch and 15-amp circuit breaker.



EMW-1
StaticGard™ Maintenance Workstation

StaticGard™ Technician's Workstation

Model No. ETW-1

- 5-drawer cabinet (169 adjustable compartments).
- Powered, fixed shelf: 18 in. high (clear height) x 18 in. deep (457 mm x 457 mm).
- Prewired with 6 duplex receptacles connected through a GFCI receptacle.
- Lighted on/off switch and 15-amp circuit breaker.



ETW-1
StaticGard™ Technician's Workstation

StaticGard™ Inspector's Workstation

Model No. EIW-1

- 5-drawer cabinet (169 adjustable compartments).
- Powered, fixed shelf adjusts from 12 in. to 22 in. (305 mm to 559 mm).
- Prewired with two duplex receptacles connected through a GFCI receptacle.
- Lighted on/off switch and 15-amp circuit breaker.



EIW-1
StaticGard™ Inspector's Workstation

StaticGard™ Packer's Workstation

Model No. EPW-1

- 4-drawer cabinet (64 adjustable compartments).
- Large clear 72 in. x 36 in. (1829 mm x 914 mm) work surface.



EPW-1
StaticGard™ Packer's Workstation

STATICGARD™ WORKSTATIONS

Optional Casters

Add "W" to end of workstation model number.

Available on ETW, EIW, and EPW models only.

- 3 in. (76 mm) appliance style double casters.
- Lockable.
- Allow for easy mobility.
- When ordered with casters, workstations will also include lock-in/lock-out latches for all drawers.

Sentry 100* Workstations

Add "SG" before workstation model number.

- StaticGard™ Sentry 100 workstations are tested and certified at 100 volts using ESD Association criteria.
- Point-to-point resistance greater than or equal to 1×10^6 ohms and less than or equal to 1×10^8 ; plus a point-to-ground resistance greater than or equal to 1×10^6 ohms and less than or equal to 1×10^8 ohms.
- Sentry 100 workstations carry certification of their performance and have been validated by independent third-party testing.

*Patent No. 5350228



Inert gas housing and humidity controller.

Inert Gas Housings

The cabinet housing is designed for holding inert gases at flow rates of 6-60 standard cubic feet per hour at low optimum pressures. At the lower flow rate the relative humidity is reduced below 50% in less than one hour. This performance meets MIL-STD-883A "Test methods and procedures for microelectronics" as outlined in method 2010-2017.1. At higher flow rates relative humidity is reduced even faster.

StaticGard™ Drawer Interior Accessories

Quarter Trays

- Trays measure 12-1/2 in. x 12-1/2 in. (318 mm x 318 mm)
- Can be used with drawer Model #s. 20 or 25.
- 20, 1-1/4 x 2-1/4 x 2-7/8 in. (32 x 57 x 73 mm) compartments

Bins and Bin Dividers

Partitions and Dividers

Add "SG" to partition or divider model numbers available.

Partitions and dividers for StaticGard™ drawers have special coating and materials that make them safe for use in static-sensitive environments.

Additional accessories include: ESD safe seating, work surface and corner shelves, back panels, conductive mat kits, wrist straps, grounding systems, ionizing equipment and circuit board drawer inserts.

For more information on the full line of StaticGard™ equipment, please call 1-800-523-9462.

Inert Gas Housings

MODEL #	FOR USE AS	OVERALL HEIGHT
IG0175RH1	Bench	33 in. (838 mm)
IG0200RH1	Stool	37 in. (940 mm)
IG0245RH1	Counter	44 in. (1118 mm)
IG0340LH1	Eye Level	59 in. (1499 mm)
IG0340RH1	Eye Level	59 in. (1499 mm)

Bins and Bin Dividers

BIN MODEL #	COMPARTMENT SIZE(H X W X D)	USED WITH DRAWER MODEL #	MAX. NO. PER DRAWER	BIN DIVIDER MODEL #
CBN2544	2-1/8 x 3 x 3 in. (54 x 76 x 76 mm)	20 or 25	64	CBND254
CBN2548	2-1/8 x 3 x 6-1/8 in. (54 x 76 x 156 mm)	20 or 25	32	CBND254
CBN2588	2-1/8 x 6-1/8 x 6-1/8 in. (54 x 156 x 156 mm)	20 or 25	16	CBND258
CBN25816	2-1/8 x 6-1/8 x 12-1/4 in. (54 x 156 x 311 mm)	20 or 25	8	CBND258
CBN3548	3-3/4 x 3 x 6-1/8 in. (95 x 76 x 156 mm)	30 or 35	32	CBND354
CBN3588	3-3/4 x 6-1/8 x 6-1/8 in. (95 x 156 x 156 mm)	30 or 35	16	CBND358
CBN35816	3-3/4 x 6-1/8 x 12-1/4 in. (95 x 156 x 311 mm)	30 or 35	8	CBND358

Mobile Cabinets

Stanley® Vidmar® mobile storage cabinets keep everything organized wherever you're working. Heavy-duty casters make these cabinets easy to move, so they can be positioned anywhere in your facility. All mobile cabinets require the Lock-in/Lock-out feature. Can be ordered without partitions and dividers. Choose from five pre-configured mobile cabinets on this page, or build your own.



RP1420AL
Standard, 155
Includes MR latches
4 Drawers w/ FR-01 Foam
21 Compartments
Usable Drawer Heights
2-1/4 in. (57 mm)
3-7/8 in. (98 mm)
4-5/8 in. (117 mm)
10-1/8 in. (257 mm)



RP1117AL
Shallow Depth, 175
Includes MR latches
5 Drawers w/ FR-01 Foam
18 Compartments
Usable Drawer Heights
2-1/4 in. (57 mm)
3 in. (76 mm)
3-7/8 in. (98 mm)
5-3/8 in. (137 mm)
8-1/2 in. (216 mm)



RP1933AL
Shallow Depth, 200
Includes MR latches
8 Drawers w/ FR-01 Foam
24 Compartments
Usable Drawer Heights
2-1/4 in. (57 mm)
3-7/8 in. (98 mm)
5-3/8 in. (137 mm)

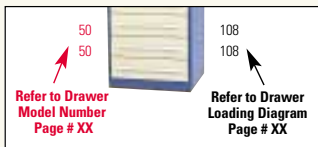

RP1118AL
Extra Wide Shallow Depth, 175
Includes MR latches
5 Drawers w/ FR-01 Foam
32 Compartments
Usable Drawer Heights
2-1/4 in. (57 mm)
3 in. (76 mm)
3-7/8 in. (98 mm)
5-3/8 in. (137 mm)
8-1/2 in. (216 mm)



RP1934AL
Extra Wide Shallow Depth, 200
Includes MR latches
8 Drawers w/ FR-01 Foam
44 Compartments
Usable Drawer Heights
2-1/4 in. (57 mm)
3-7/8 in. (98 mm)
5-3/8 in. (137 mm)



Mobile Accessories

Type of caster kit should be specified when ordering cabinets for mobile applications. (Lock-in/lock-out latches or Single Drawer Release are required for all mobile applications.) Use only for Model 200 housing or smaller. Cabinets, drawers, and tops not included in kits. For XW and DW cabinets with doors, call customer service about special five-wheel base at 1-800-523-9462.

Cabinet Top Tray

- Cabinet top trays attach through knockouts available on all cabinets.
- One-inch (25 mm) height.
- Ideal for keeping small or rolling parts and tools safe and close at hand.



Cabinet Top Trays

Tow Bar

Model # UTB-22 (Also order appropriate adapter kit.)

Adapter kits:

Model # UTBAK-22, for all housings except shallow depth

Model # UTBAK-22-LW for shallow depth housings

- Tow bars are used to tow cabinets in mobile applications.
- Attached to base of all housing styles with adapter kit.
- Use tow bars only on cabinets with lock-in/lock-out latches.
- Use only on cabinet heights of 175 or smaller.



Tow Bar

Additional Weld Feature

See chart for model #s.

Additional welds are added for towing applications to maintain cabinet strength and performance.

Cabinet Top Trays

MODEL #	USED WITH CABINETS
CTTST	Standard Cabinets
CTTSV	Small Version Cabinets
CTTLW	Shallow Depth Cabinets
CTTXW	Extra Wide Cabinets
CTTDW	Double Wide Cabinets
CTTXL	Extra Wide, Shallow Depth
CTTDL	Double Wide Shallow Depth
CTT/SL	Small Version Shallow Depth

Tow Bars-Additional Weld Feature

MODEL #	USED WITH CABINETS
AWFST	Standard Cabinets, XW and DW
AWFLW	Shallow Depth Cabinets
AWFSV	Extra Wide Cabinets
AWFXL	Shallow Depth, Extra Wide
AWFDW	Double Wide

Casters With Channel Options

USED WITH HOUSING NO FEET FEATURE	2 IN. HARD RUBBER WHEEL		5 IN. HARD RUBBER WHEEL		6 IN. POLYURETHANE TREAD LOCKED TO POLYOLEFIN CORE		HANDLES (ORDERED SEPARATELY)
	WT. CAP. 200 LB/WHL (90 KG)	WHEEL DIA. 2 IN. (50 MM)	WT. CAP. 350 LB/WHL (158 KG)	WHEEL DIA. 5 IN. (127 MM)	WT. CAP. 900 LB/WHL (408 KG)	WHEEL DIA. 6 IN. (152 MM)	
One Cabinet Mobile Base	4 Swivel Casters With Channel		2 Rigid 2 Swivel Casters With Channel		2 Rigid 2 Swivel Casters With Channel		
Standard	1MB2HRSTS		1MB5HRST		1MB6PPST		MHST
Shallow Depth	1MB2HRLWS		1MB5HRLW		1MB6PPLW		MHLW
Small Version	1MB2HRSVS		1MB5HRSV		1MB6PPSV		MHSV
Extra Wide			1MB5HRXW		1MB6PPXW		MHST
Extra Wide Shallow Depth			1MB5HRXL		1MB6PPXL		MHLW
Double Wide			1MB5HRDW		1MB6PPDW		MHST
Double Wide Shallow Depth			1MB5HRDL				MHST
Small Version Shallow Depth	1MB2HRSL		1MB5HRSL				MHLW
Two Cabinet Mobile Base	6 Swivel Casters With Channel		2 Rigid 2 Swivel Casters With Channel		2 Rigid 2 Swivel Casters With Channel		2 Rigid 2 Swivel Casters With Channel
Standard	2MB2HRSTS		2MB5HRST		2MB6PPST		MHST
Shallow Depth	2MB2HRLWS				2MB6PPLW		MHLW
Small Version			2MB5HRSV		2MB6PPSV		MHSV
Two Cabinet Mobile Base					4 Swivel Casters With Channel		4 Swivel Casters With Channel
Standard					2MB6PPSTS		MHST
Shallow Depth					2MB6PPLWS		MHLW
Extra Wide					2MB6PPXWS		MHST
Three Cabinet Mobile Base			2 Rigid 4 Swivel Casters With Channel		2 Rigid 2 Swivel Casters With Channel		
Standard			3MB5HRST		3MB6PPST		MHST
Small Version					3MB6PPSV		MHSV

Mobile Workcenters

Stanley® Vidmar® workcenters offer multiple drawers in different heights and widths and hinged left or right doors, all within the same workcenter. All modular.

- Drawer capacity and drawer carriage system capacity 400 lbs.
- Heavy duty, 900 lbs. capacity casters on all units (7-3/4" overall height). 1,200 lbs. capacity (9") spring loaded casters available.
- Mobile handle with black end caps matches cabinet color.
- Doors and drawers keyed alike.
- Options:
Cabinet Widths: 60" and 45" wide
Single Drawer Widths: 57" and 42"
Drawer Bank Widths: 27" and 20"
Cabinet Heights: 31" (0175) and 35" (0200)
Drawer Heights: Standard Stanley® Vidmar® sizes 020 – 090
Door Heights: Standard Stanley® Vidmar® sizes 140 – 165 Series
Adjustable shelves available in 400 and 800 lbs. capacities
Drawer partitions and dividers available
Ribbed rubber mat or 1-3/4" thick hardwood tops
Special configurations available upon request



Mobile Workcenter
Cabinet with wide drawer, one bank of drawers, and one Hinged Door (left or right side.)



Mobile Workcenter
Cabinet with wide drawer and two banks of drawers.

Utility Cart

Model # RP5000 Stanley® Vidmar® Utility Cart #40 Drawer

Model # RP5001 Stanley® Vidmar® Utility Cart #20 Drawer

- Lightweight, heavy duty, easy to move utility work cart
- 16,910 total cubic inches of storage space.
Overall storage capacity 600 lbs.
- Holds up to 150 lbs. per drawer.
- Dimensions:
Length (top and bottom) 30"
Width (top) 21.38", (bottom) 30"
Overall height (with casters) 37"
Weight (empty) 163 pounds
- Available with one or two drawers, both with an open shelf and bottom pan
- The drawer carriage is a welded steel frame with steel rollers and roller bearing guides for smoothness of travel at full capacity.
- Drawers can be sub-divided using traditional Stanley® Vidmar® drawer partitions and dividers
- Drawers are completely inter-changeable with Stanley® Vidmar® cabinets



Utility Cart

Battens

Round or flat battens are adjustable metal bars used to keep items on shelves in mobile or shipboard storage. Use with any style shelf cabinet.

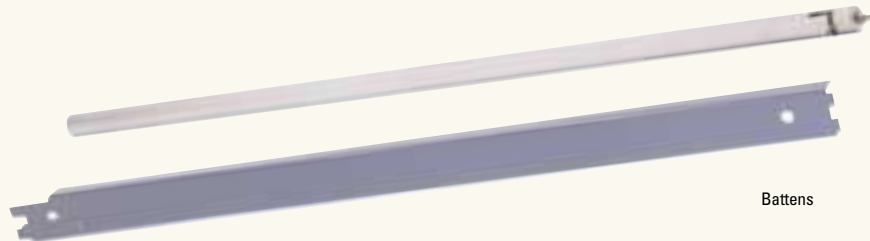

Battens

Mobile Control Center

Designed to be the most flexible in-plant floor control center available.

- Universal components: standard 245 cabinet, corner desk/bookcase, safety panel, and integral pallet base.
- Easy to assemble in any configuration.
- Well-lit work space and counter surface around two sides.
- Safety panel prevents chair roll-away and buffers noise.
- Pallet base allows effortless relocation with forklift.
- Available knocked down or fully assembled.

Battens

MODEL #		USED WITH CABINETS	LENGTH
ROUND	FLAT		
BT100	BT200	Standard	28 in. (711 mm)
BTLW100	BTLW200	Shallow Depth	28 in. (711 mm)
BTXW100	BTXW200	Extra Wide	43-1/8 in. (1095 mm)
BTDW100	BTDW200	Double Wide	58-1/4 in. (1480 mm)
BTSV100	BTSV200	Small Version	20-7/8 in. (530 mm)



MCC

MCC

MODEL #	USABLE DRAWER HEIGHT	# OF DRAWERS	COMPARTMENT SIZE	# OF COMPARTMENTS PER DRAWER
MCC-1 5 Drawers	2-1/4 in. (57 mm)	1	None	
	3 in. (76 mm)	1	None	
	5-3/8 in. (137 mm)	1	None	
	11-3/4 in. (298 mm)	2	12-1/4 in. x 25-1/8 in. (31mm x 638 mm)	2 hanging file compartments
MCC-2 5 Drawers	3 in. (76 mm)	1	VP3	11
	3-7/8 in. (98 mm)	2	VP3	11
	11-3/4 in. (298 mm)	2	12-1/4 in. x 25-1/8 in. (31mm x 638 mm)	2 hanging file compartments

MODEL #	USABLE DRAWER HEIGHT	# OF DRAWERS	COMPARTMENT SIZE	# OF COMPARTMENTS PER DRAWER
MCC-3 5 Drawers	3 in. (76 mm)	1	VP19	13
	3-7/8 in. (98 mm)	2	VP19	13
	11-3/4 in. (298 mm)	2	12-1/4 in. x 25-1/8 in. (31mm x 638 mm)	2 hanging file compartments
MCC-4 6 Drawers	3 in. (76 mm)	1	VP19	13
	3-7/8 in. (98 mm)	2	VP19	13
	5-3/8 in. (137 mm)	2	VP15	9
	11-3/4 in. (298 mm)	1	PS90	2

The Vidmar® D-I-S™ System (Drawers-In-Shelving System)

Combines the organizational benefits of drawers and open shelves. Versatile and easy to access for large items on open shelves with the efficiency of drawer storage for small to medium items. The D-I-S™ System keeps materials organized and easily retrieved. Helps increase storage utilization over standard shelving.

Four Standard Stocked Modules:

- Available in four pre-configured drawer modules (A,B,C,D)
- Sizes:
 - Outside Footprint:
 - Left to Right 30.75"
 - Front to Back 30.00"
- Nominal Overall System Height 7 ft.
- Closed sides and backs.
- Heavy-duty roller bearing carriage with 400 lbs. per-drawer load capacity.
- One year warranty on the entire system and lifetime warranty on the drawers.
- Installation and anchoring to the floor is required.



40 88
40 88
40 88

Module A
DIS120A



30 88
30 88
30 88
30 88

Module B
DIS120B

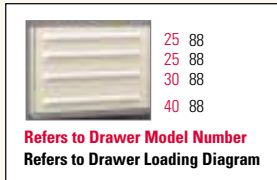

25 88
25 88
35 88
35 88

Module C
DIS120C



25 88
25 88
30 88
40 88

Module D
DIS120D

D-I-S™ DRAWERS-IN-SHELVING

Drawers

- Standard 16 compartment drawer.
- Inside usable dimensions are 25-1/8" x 25-1/8".
- Drawer modules can be set at most ergonomically convenient height.
- The drawer carriage system used is identical to that used on 400 lbs. capacity Vidmar® cabinet drawers.
- Drawers and interiors are interchangeable with existing Stanley® Vidmar® cabinets allowing for multiple shelf, door, and drawer combinations.
- All drawers can be sub-divided using traditional Vidmar® drawer partitions and dividers.
- Drawer pulls accommodate paper labels and vinyl shields.



Drawers

Shelves

- Adjustable shelving with 500 lbs. per-shelf load capacity.
- Nominal usable shelf space 30.00" x 30.00"
- Industrial powder coated gray shelving with off-white drawers in stock.



Shelves

Design a D-I-S™ System (Drawers & Shelves) to Meet Your Storage Needs

Custom D-I-S™ Options

- 15 drawer heights available.
- Custom drawer configurations up to 120 drawer points.
- Over 25 pre-configured drawer interiors available.
- Extended side walls
- Shelf doors, hinge lock bars and door locks for added security
- Roll out shelves for easy accessibility
- Multi-level mezzanine systems available.
- Most standard Vidmar® drawer accessories are available including:
- NC tool holders,
- Drawer security panel and individual drawer locks
- Drawer padlock and aluminum battens.
- Available in 10 standard Vidmar® colors. Custom Vidmar® colors, consult your Vidmar® Sales Engineer.



Customized D-I-S™ System

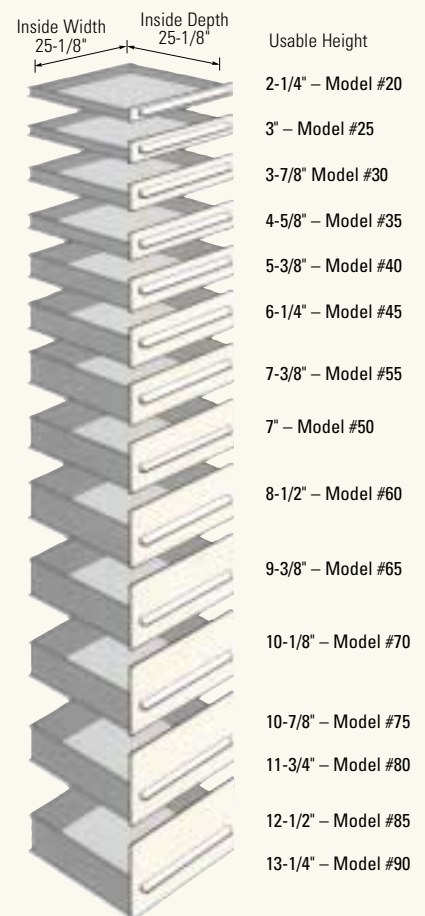

Drawer Options

Toll Free Customer Service Number: 1-800-523-9462
Customer Service FAX Number: 1-800-523-9934

Mezzanine Systems

Stanley® Vidmar® mezzanine systems are completely modular.

The basic components consist of five modules:

1. Two Stanley® Vidmar® cabinets for the top and bottom.
2. A Stanley® Vidmar® middle shelf cabinet. The middle cabinet provides height and space for overflow inventory.
3. Walkway support system. This support rack simply slides into each upper level cabinet.
4. Grating. This heavy-duty grating drops into place like ceiling tiles.
5. Railings and stairs.
6. All components simply bolt together through pre-existing access holes.

Best of all, your mezzanine can be reconfigured as needed—even with cabinets fully loaded!

- Expansion modules allow system configuration to grow as needs change.
- Single- and/or double-aisle modules can be incorporated into any existing configuration to adapt to changing plant conditions.
- Pass-through modules can be incorporated into any configuration, allowing single or double cabinet width pass-throughs from aisle- to-aisle on both floor level and/or multi-levels.

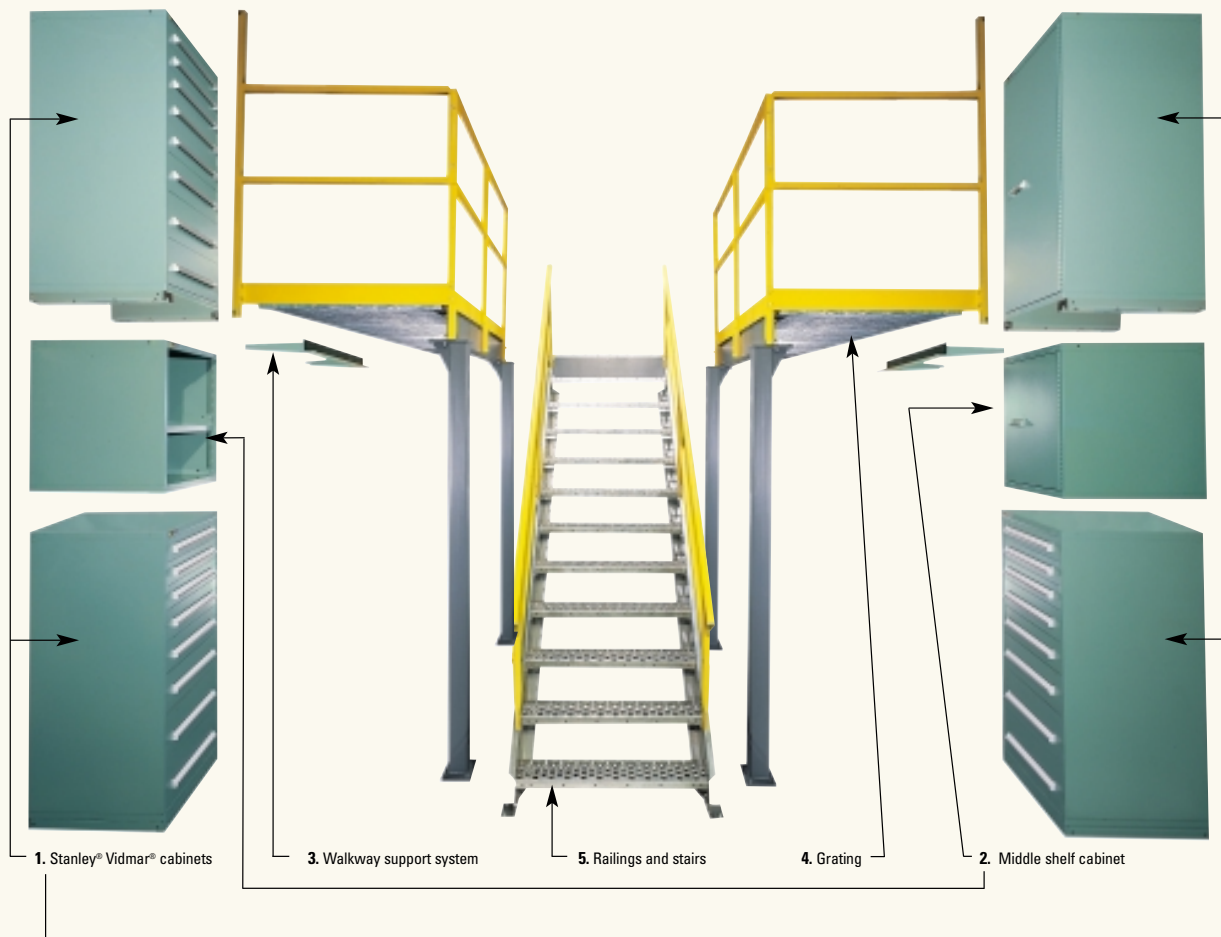

MaxiMezz™ System

A MaxiMezz™ System consists of Stanley® Vidmar® cabinets stacked two high into rows with an intermediate shelf cabinet placed between the top and bottom cabinets. Walkway support systems with grating are added along with railings and stairs. MaxiMezz™ systems can be configured in a number of ways to meet specific needs and can be reconfigured even when cabinets are loaded to meet changing requirements.

MiniMezz® System

The simplest mezzanine requires no grating or walkway system, and can be configured with any Stanley® Vidmar® cabinet. It consists of a row of stacked cabinets, plus railings, stairs, and a walking mat placed on top of another row of cabinets which serves as the mezzanine platform, providing even higher density storage.

Rail Kits

Available in 30 in. (762 mm) and 60 in. (1524 mm) widths for cabinet width openings and 36 in. (914 mm), 42 in. (1067 mm), and 48 in. (1219 mm) for aisle ends. Actual railing application determined by system configuration.

Stack Top Feature

See chart for model #s.

Cabinet tops can be furnished with threaded inserts attached to facilitate stacking of cabinets.

Pierced Top Feature

See chart for model #s.

Cabinet top knockouts—standard on all cabinets—can be removed at the factory for easier on-site installation of tops, trays, and other accessories.

Stack Top Feature

MODEL #	USED WITH HOUSING
STFST	Standard
STFXW	Extra Wide
STFDW	Double Wide
STFSV	Small Version
STFLW	Shallow Depth
STFXL	Extra Wide, Shallow Depth
STFDL	Double Wide, Shallow Depth
STFSL	Small Version, Shallow Depth

Pierced Top Feature

MODEL #	USED WITH HOUSING
PTFST	Standard
PTFXW	Extra Wide
PTFDW	Double Wide
PTFSV	Small Version
PTFLW	Shallow Depth
PTFXL	Extra Wide, Shallow Depth
PTFDL	Double Wide, Shallow Depth
PTFSL	Small Version, Shallow Depth



MaxiMezz System™



MiniMezz System®

Drawer Accessories

Drawer accessories customize a drawer's interior to your inventory or tools.

- Partitions and dividers can be easily moved and rearranged.
- Change interior configurations as inventory or storage requirements change.
- Additional accessories not listed are available. (For more information call Customer Service.)

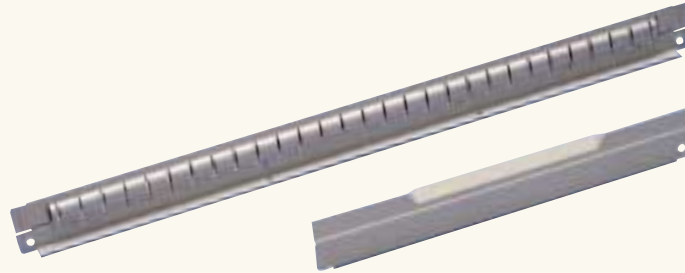

Drawer Partitions

Drawer Dividers

Drawer Partitions

- Partitions span entire width or depth of a drawer.
- Slide into slots on drawer walls and are fastened to drawer bottom at pre-punched locations.
- Use with dividers to customize drawer interiors.
- Includes hardware for fastening to drawer bottom.

Drawer Dividers

- Use with partitions to subdivide drawer space.

NOTE: Dividers that are 9-1/2 in. (241 mm) long and over are supplied with screws for fastening to drawer bottom.



Drawer Partitions

DRAWER TYPE	# OF SPACES	APPROX. LENGTH	FITS DRAWER MODELS 20 AND 25 1-7/8 IN. (48 MM) HT.	FITS DRAWER MODELS 30 AND 35 2-7/8 IN. (73 MM) HT.	FITS DRAWER MODELS 40 AND 45 4-1/2 IN. (114 MM) HT.	FITS DRAWER MODELS 50 AND LARGER 5-1/4 IN. (133 MM) HT.
Standard/LW/SV	32	25-1/2 in. (648 mm)	P20	P30	P40	P50
Extra Wide	51	40-1/2 in. (1029 mm)	P2051	P3051	P4051	P5051
Double Wide	70	55-5/8 in. (1413 mm)	P2070	P3070	P4070	P5070
SL, LW XL & DL (front to back)	24	19 in. (483 mm)	P2024	P3024	P4024	P5024

Standard Drawer Dividers

# OF SPACES	APPROX. LENGTH	USABLE COMPARTMENT WIDTH	FITS DRAWER MODELS 20 AND 25 1-7/8 IN. (48 MM) HT.	FITS DRAWER MODELS 30 AND 35 2-7/8 IN. (73 MM) HT.	FITS DRAWER MODELS 40 AND 45 4-1/2 IN. (114 MM) HT.	FITS DRAWER MODELS 50 AND LARGER 5-1/4 IN. (133 MM) HT.
2	1-1/2 in. (38 mm)	1-1/8 in. (29 mm)	D2002	D3002	—	—
3	2-1/4 in. (57 mm)	1-7/8 in. (48 mm)	D2003	D3003	—	—
4	3 in. (76 mm)	2-5/8 in. (67 mm)	D2004	D3004	D4004	D5004
5	3-7/8 in. (98 mm)	3-1/2 in. (89 mm)	D2005	D3005	D4005	D5005
6	4-5/8 in. (117 mm)	4-1/4 in. (108 mm)	D2006	D3006	D4006	D5006
7	5-1/2 in. (140 mm)	5-1/8 in. (130 mm)	D2007	D3007	D4007	D5007
8	6-1/4 in. (159 mm)	5-7/8 in. (149 mm)	D2008	D3008	D4008	D5008
9	7 in. (178 mm)	6-5/8 in. (168 mm)	D2009	D3009	D4009	D5009
10	7-7/8 in. (200 mm)	7-1/2 in. (190 mm)	D2010	D3010	D4010	D5010
11	8-5/8 in. (219 mm)	8-1/4 in. (210 mm)	D2011	D3011	D4011	D5011
12	9-1/2 in. (241 mm)	9-1/8 in. (232 mm)	D2012	D3012	D4012	D5012
13	10-1/4 in. (260 mm)	9-7/8 in. (251 mm)	D2013	D3013	D4013	D5013
14	11 in. (279 mm)	10-5/8 in. (270 mm)	D2014	D3014	D4014	D5014
15	11-7/8 in. (302 mm)	11-1/2 in. (292 mm)	D2015	D3015	D4015	D5015
16*	12-5/8 in. (321 mm)	12-1/4 in. (311 mm)	D2016	D3016	D4016	D5016
17	13-1/2 in. (343 mm)	13-1/8 in. (333 mm)	D2017	D3017	D4017	D5017
18	14-1/4 in. (362 mm)	13-7/8 in. (352 mm)	D2018	D3018	D4018	D5018
19	15 in. (381 mm)	14-5/8 in. (371 mm)	D2019	D3019	D4019	D5019
20	15-7/8 in. (403 mm)	15-1/2 in. (394 mm)	D2020	D3020	D4020	D5020
21	16-5/8 in. (422 mm)	16-1/4 in. (413 mm)	D2021	D3021	D4021	D5021
22	17-1/2 in. (445 mm)	17-1/8 in. (435 mm)	D2022	D3022	D4022	D5022
23*	18 in. (457 mm)	17-7/8 in. (454 mm)	D2023	D3023	D4023	D5023
24*	19 in. (483 mm)	18-5/8 in. (473 mm)	D2024	D3024	D4024	D5024
25	19-7/8 in. (505 mm)	19-1/2 in. (495 mm)	D2025	D3025	D4025	D5025
26	20-5/8 in. (524 mm)	20-1/4 in. (514 mm)	D2026	D3026	D4026	D5026
27	21-1/2 in. (546 mm)	21-1/8 in. (537 mm)	D2027	D3027	D4027	D5027
28	22-1/4 in. (565 mm)	21-7/8 in. (556 mm)	D2028	D3028	D4028	D5028
29	23 in. (584 mm)	22-5/8 in. (575 mm)	D2029	D3029	D4029	D5029
32**	25-3/8 in. (645 mm)	25-1/8 in. (638 mm)	DS2032	DS3032	DS4032	DS5032

*Also available in straight dividers.
**Only available in straight dividers.

DRAWER ACCESSORIES

ACCESSORIES

Plastic Bins

- Ideal for storing smaller items.
- Bins can quickly be removed for easy handling, issuing, and counting.

In any drawer using bins, it is recommended that a single side-to-side partition be installed.

Snap-on plastic label holders and paper labels must be ordered separately.

Bin Dividers

(Not Shown)

Bin Label Holders

Model # BLH02

- Includes paper labels.
- Dimensions (h x w)
2-1/8 in. x 5/8 in. (54 mm x 16 mm).

Plastic Quarter Trays

Model # QT20

- Quarter trays take up one quarter of a standard drawer.
- 20 Compartments, 1-1/4 x 2-1/4 x 2-7/8 in. (32 x 57 x 73 mm)
- Both partitions and dividers should be used when using less than a full drawer of quarter trays.

Label Holders

- Provides instant identification of drawer compartment contents.
- Label holders snap directly onto the divider.
- Paper labels and vinyl protective shields included.

Adhesive Backed Label Holders

Model # ALH13

(for use with dividers 05 and larger and bins BN2588 and larger.)

- 1 in. x 3 in. (25 mm x 76 mm).
- Provides instant identification of drawer compartment contents.
- Adheres directly to the divider, partition, or plastic bin.



Plastic Bins



Plastic Quarter Trays

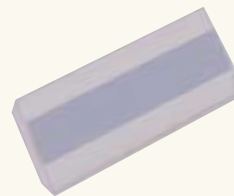

Adhesive Backed Label Holders



Label Holders

Plastic Bins

MODEL #	DIMENSIONS (H X W X D)	USED WITH DRAWER MODEL #	MAX # OF BINS PER DRAWER
BN2544	2-1/8 in. x 3 in. x 3 in. (54 mm x 76 mm x 76 mm)	20 or 25	64
BN2548	2-1/8 in. x 3 in. x 6-1/8 in. (54 mm x 76 mm x 156 mm)	20 or 25	32
BN2588	2-1/8 in. x 6-1/8 in. x 6-1/8 in. (54 mm x 156 mm x 156 mm)	20 or 25	16
BN25816	2-1/8 in. x 6-1/8 in. x 12-1/4 in. (54 mm x 156 mm x 311 mm)	20 or 25	8
BN3548	3-3/4 in. x 3 in. x 6-1/8 in. (95 mm x 76 mm x 156 mm)	30 or 35	32
BN3588	3-3/4 in. x 6-1/8 in. x 6-1/8 in. (95 mm x 156 mm x 156 mm)	30 or 35	16
BN35816	3-3/4 in. x 6-1/8 in. x 12 in. (95 mm x 156 mm x 305 mm)	30 or 35	8

Bin Dividers

MODEL #	USED WITH BIN MODEL #
BND254	BN2544 or BN2548
BND258	BN2588 or BN25816
BND354	BN3548
BND358	BN3588 or BN35816

Label holders

MODEL #	FITS DIVIDER MODEL # ENDING IN	LENGTH
LH04	04 and larger	2-5/8 in. (67 mm)
LH06	06 and larger	4-3/16 in. (106 mm)
LH08	08 and larger	5-3/4 in. (146 mm)

Toll Free Customer Service Number: 1-800-523-9462
Customer Service FAX Number: 1-800-523-9934

Hanging File Frame

Model #s PS70, SVPS70, LWPS70, XWPS70

- Designed to be used with model 70 drawer or larger.
- One filing kit fills a standard drawer.
- Holds two rows of hanging files.
- Includes two letter-size steel frames and a file divider.

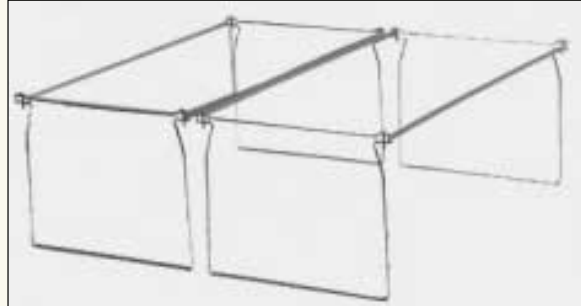

Hanging File Frame

Card Trays

- Efficiently stores up to 10,000 cards.
- Available in the five most popular card sizes.

Plastic Groove Trays and Dividers

- Available in three sizes.
- Store and separate elongated items.
- Trays take up one-fifth of a standard drawer.
- Can be divided into compartments with groove tray label holders.



Card Trays

Groove Tray Divider Label Holders

- Supplied with paper labels and vinyl protective shield.

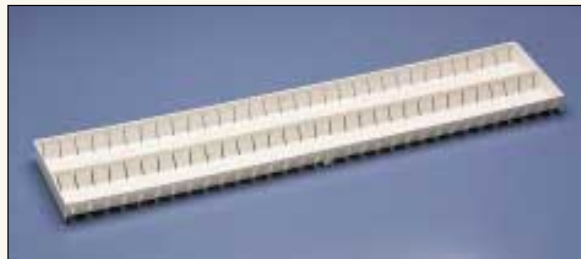

Plastic Groove Tray

Groove Tray Divider Label Holders

MODEL #	USED WITH GROOVE TRAY MODEL
GTL22	PGT22
GTL37	PGT37
GTL58	PGT58

Plastic Groove Trays and Dividers

MODEL #	DRAWER MODEL	# OF GROOVES	GROOVE OPENING,	TRAY WIDTH,	QTY. PER DRAWER	LABEL HOLDER (PURCHASED SEPARATELY)
PGT22	20	5	7/8 in. (22 mm)	5 in. (127 mm)	5	GTL22
PGT37	20	3	1-1/2 in. (38 mm)	5 in. (127 mm)	5	GTL37
PGT58	25	2	2-1/4 in. (57 mm)	5 in. (127 mm)	5	GTL58

Card Trays

MODEL #	CARD SIZE, IN. (MM)	TRAYS PER SET	STANDARD DRAWER MODEL #	CARD CAPACITY/ PER SET
CT35	3 x 5 in. (76 x 127 mm)	4	35	10,000
CT46	4 x 6 in. (102 x 152 mm)	4	40	10,000
CT47	4 x 7 in. (102 x 178 mm)	3	40	7,500
CT58	5 x 8 in. (127 x 203 mm)	3	45	7,500
CT100	3-1/4 x 7-3/8 in. (83 x 187 mm) 80-column data processing card	3	35	7,500