

# TABLE OF CONTENTS

## Radial Roller Bearings

1. Radial Roller Bearing Overview .....	Page 4 & 5
2. Configurations & Numbering System .....	Page 6 thru 9
3. Retainer Selection .....	Page 10
4. Series Code & Race and Roller Material .....	Page 11
5. Technical	
A. Class of Precision .....	Page 12
B. Basics of Load Ratings and Bearing Selection Criteria .....	Page 12
C. Limiting Speed .....	Page 12
D. Limiting Speed Graph .....	Page 13
6. Product Data .....	Page 14 thru 27
7. Applications .....	Page 28 & 29

## Thrust Bearings

1. Thrust Bearing Overview .....	Page 30 & 31
2. Cylindrical Thrust	
A. Types .....	Page 32 thru 34
B. Numbering System .....	Page 35
C. Product Data .....	Page 36 thru 40
3. Tapered Thrust	
A. Types .....	Page 41 & 42
B. Numbering System .....	Page 43
C. Product Data .....	Page 44 & 45
4. Tandem Thrust	
A. Designs .....	Page 46 & 47
B. Product Data .....	Page 48 thru 50
5. Special Designs .....	Page 51
6. Applications .....	Page 52 thru 55

## Journal Bearings

1. Journal Bearing Overview .....	Page 57
2. Product Data .....	Page 58 & 59

## Engineering

1. Table of Contents .....	60
2. Gaging Practices .....	Page 61 & 62
3. Tolerances	
A. Radial Bearings, RBEC 1, 3 & 5 .....	Page 63 & 64
B. Journal Bearings .....	Page 64
C. Thrust Bearings .....	Page 65 thru 67
4. Life - Load - Speed .....	Page 68 thru 72
5. Fitting Practice	
A. Radial Bearing Unmounted Internal Clearance .....	Page 72 thru 75
B. Radial Bearing Mounting Practice - Shaft and Housing Fits .....	Page 76 thru 78
C. Thrust Bearing Mounting Practice - Shaft and Housing Fits .....	Page 79 thru 81
D. Journal Bearing - Shaft and Housing Fits .....	Page 82
6. Lubrication .....	Page 83 thru 87

# ***Bearings For Demanding Applications...***



## **ROLLWAY® Cylindrical Radial Roller Bearings...**

**Catalog sizes and engineered to order bearing designs readily available.**

- RBEC 5 Precision Class Capability.
- Extra Capacity Designs.
- Multiple Retainer Designs Available.
- High Temperature Designs Available.
- Special Features...
  - *Notches.*
  - *Slots.*
  - *Aligning Features.*
  - *Carburizing Grade Materials.*

## **ROLLWAY® Roller Thrust Bearings...**

**Catalog sizes and engineered to order bearing designs readily available.**

- Cylindrical Roller Designs — Catalog and Engineered.
- Aligning, Banded and Double Acting Designs Available.
- Tapered Roller Designs — TTHD & TTVF.
- Cantilever Designs for Minimal Shoulder Support.
- Tandem Thrust 2-8 Stage Designs.
- High Temperature Designs Available.
- High Speed Designs Available.

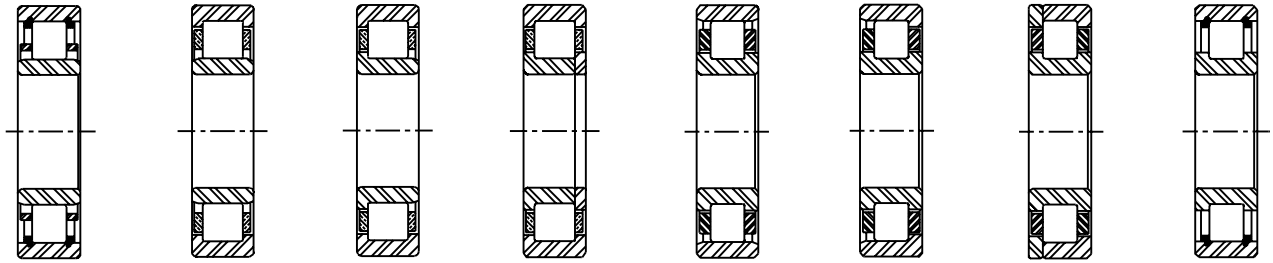

## ***Engineered Bearings For Your Applications***

**Radial Roller Bearings ..... Pages 4 thru 29**

- |          |          |          |           |          |          |           |          |
|----------|----------|----------|-----------|----------|----------|-----------|----------|
| E-####-B | E-####-U | L-####-U | LP-####-U | U-####-E | U-####-L | U-####-LP | U-####-B |
| MUC-#### | MUL-#### | MU-####  | MCS-####  | ML-####  | MN-####  | UM-####-B | M-####   |
| NU-###   | NJ-###   | NUP-###  | N-###     |          |          | MS-####   |          |

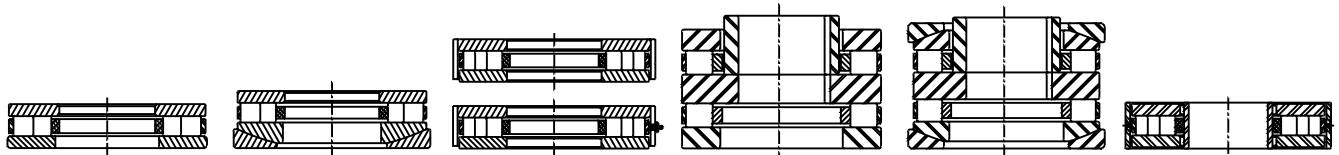
**Cylindrical Thrust Bearings ..... Pages 30 thru 40**

- |       |        |                 |        |         |         |
|-------|--------|-----------------|--------|---------|---------|
| T-### | AT-### | CT-##<br>WCT-## | DT-### | DAT-### | SDT-### |
|-------|--------|-----------------|--------|---------|---------|

**Tapered Thrust Bearings ..... Pages 41 thru 45**

- |       |           |
|-------|-----------|
| T-### | T-#####-F |
|-------|-----------|

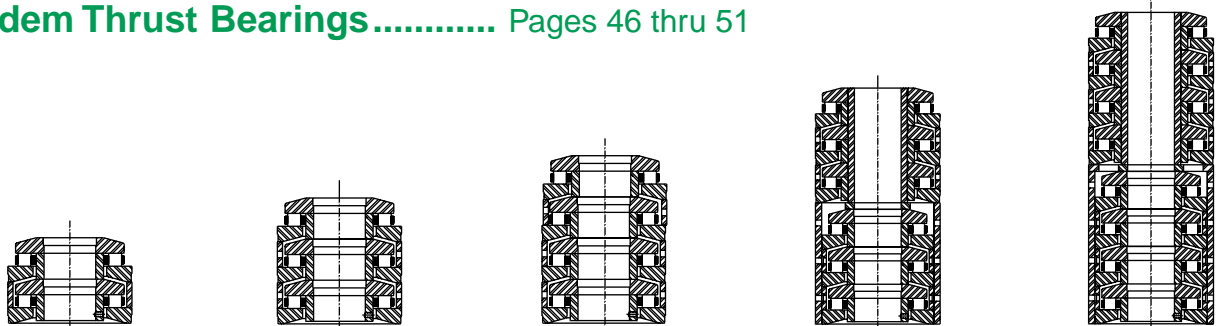
**Tandem Thrust Bearings ..... Pages 46 thru 51**

- |           |           |           |           |           |
|-----------|-----------|-----------|-----------|-----------|
| TAB-##### | TAC-##### | TAD-##### | TAF-##### | TAH-##### |
| TMB-##### | TMC-##### | TMD-##### | TMF-##### | TMH-##### |

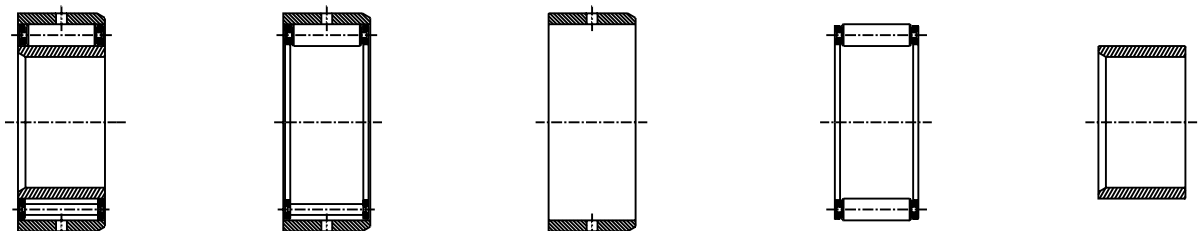
**Journal Roller Bearings ..... Pages 57 thru 59**

- |       |       |          |        |          |
|-------|-------|----------|--------|----------|
| D-### | B-### | B-###-70 | WS-### | E-###-60 |
|-------|-------|----------|--------|----------|



## *Radial Roller Bearings...*

*Since 1908 ROLLWAY Bearing produced high quality, engineered cylindrical radial roller bearings. There are hundreds of standard designs available as well as the capability to engineer bearings to satisfy your demanding applications...*





# *In The Past We Have Solved Some of The Most Demanding Bearing Challenges:*

- High speed bearings for aerospace transmissions.
- High temperature bearing designs for Poly-reactor and corrugating equipment.
- Designs for applications using low viscosity lubricants.
- Designs for vibratory and orbiting applications.
- Designs requiring anti-rotation features on the races.
- Bearings with outside diameters of 42”.

Besides providing solutions to industry’s toughest bearing applications, ROLLWAY bearings are manufactured in many standard catalog sizes and styles:

- Multiple configurations per basic size.
- Many different series available.
- Steel and Brass retainer options.
- Extra Capacity Designs.

## *ROLLWAY Standard Designs*

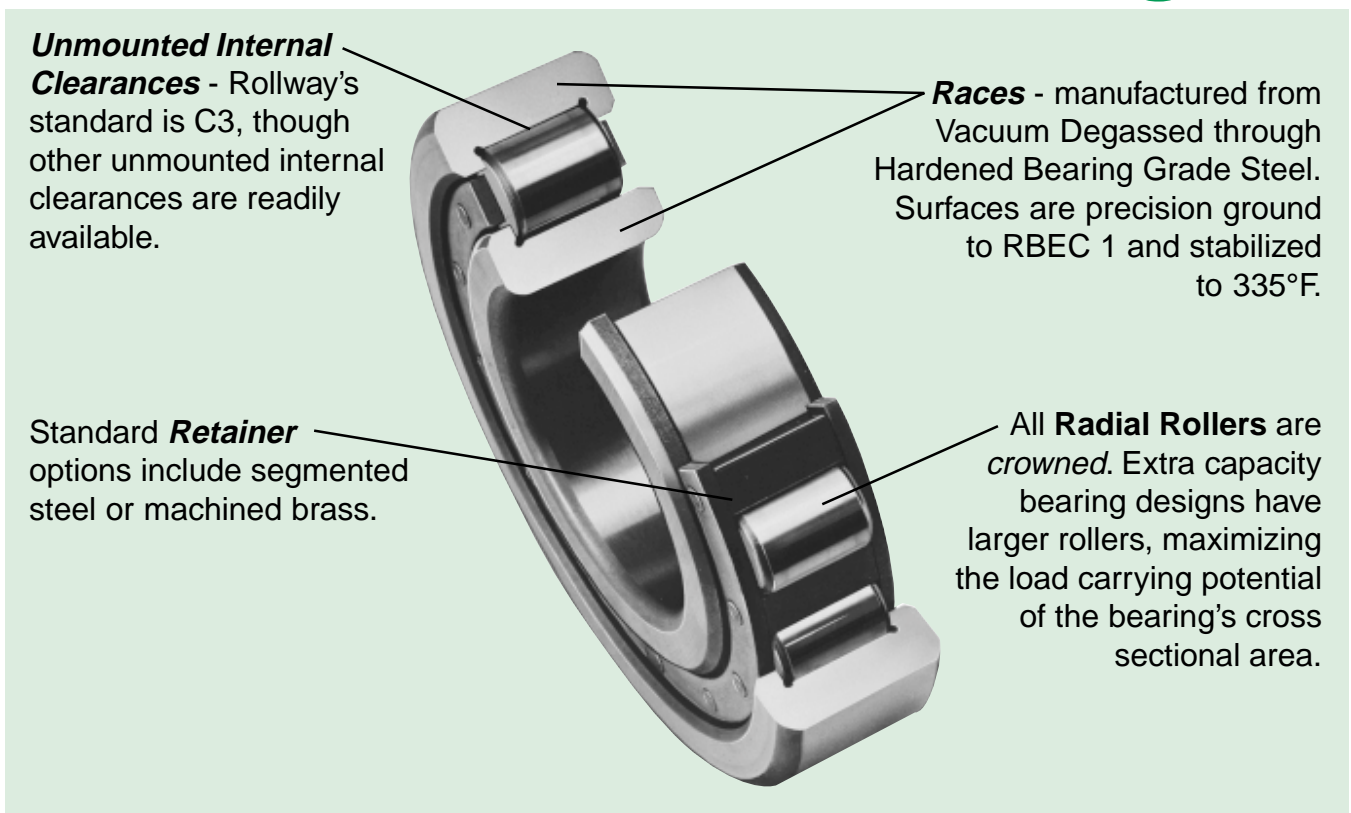



## CONFIGURATION & NUMBERING SYSTEM

**ROLLWAY® Cylindrical Radial Roller Bearings** are available in a vast variety of sizes and configurations ranging from standard cataloged 45mm ID bearings to 1,016mm outside diameter special engineered bearings. This section of the catalog covers ROLLWAY Cylindrical Radial Roller bearing configurations, part numbering, material, retainer design and limiting speeds.

### Inner Race Separable, Both Directions

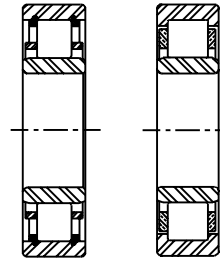

#### Number Systems

E-####-U  
E-####-B  
MUC-####  
NU-###

Two-flange (or retaining rings) outer race, straight inner race, separable bearing. For applications where axial float in both directions is desired. Roller assembly remains with the outer race.

### Inner Race Separable, One Direction

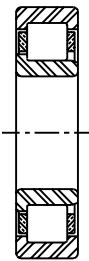

#### Number Systems

L-####-U  
MUL-####  
NJ-###

Two-flange outer race, one-flange inner race, separable bearing. For applications where axial float in one direction and axial retention in the other direction is desired. Roller assembly remains with the outer race. Will carry light thrust loads in one axial direction.

### Two Piece Inner Race, Four Flange Design

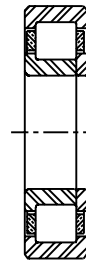

#### Number Systems

LP-####-U  
MU-####  
NUP-###

Two-flange outer race, two-flange inner race with one flange plate, separable bearing. For applications where axial retention in both directions is desired. Roller assembly remains with the outer race. Will carry light thrust loads in both axial directions.

### Outer Race Separable Both Direction



#### Number Systems

U-####-E  
MCS-####  
N-###

Straight outer race, two-flange inner race, separable bearing. For applications where axial float is desired. Roller assembly remains with the inner race.

### Outer Race Separable One Direction

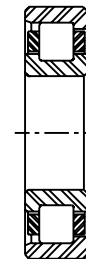

#### Number Systems

U-####-L  
ML-####

One-flange outer race, two-flange inner race, separable bearing. For applications where axial float in one direction and axial retention in the other directions is desired. Roller assembly remains with the inner race. Will carry light thrust loads in one direction.

### Two Piece Outer Race Four Flange Design



#### Number Systems

U-####-LP  
MN-####

Two-flange outer race with one flange plate, two-flange inner race, separable bearing. For applications where axial retention in both directions is desired. Roller assembly remains with the inner race. Will carry light thrust loads in both axial directions.

### Non-Separable

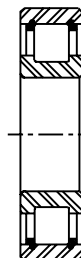

Or when supplied with a full complement of rollers.

#### Number Systems

U-####-B  
MS-####

#### Number Systems

UM-####-B  
M-####

Two snap-ring flange outer race, two-flange inner race, non-separable bearing. No axial retainer of outer race is required when inner race is properly mounted on shaft. See application drawings. Will not carry thrust loads.

### **ROLLWAY Numbering Systems...**

Over the years the ROLLWAY product offering has increased. Each new product line has its own numbering system resulting in the current offering of multiple nomenclatures. The three basic systems are **TRU-ROL**, **MAX** and **ISO**, described below and on the following two pages.

### **TRU-ROL Numbering**

This system for radial bearings is broken into 4 parts; **Prefix**, **Size Designator**, **Suffix** and **Variation code**.

Example:

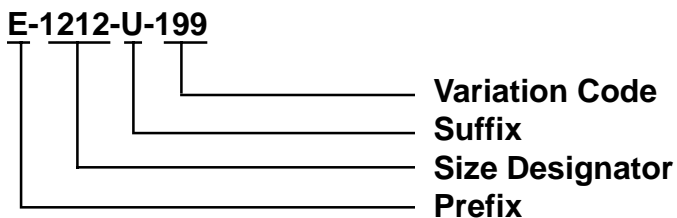

#### **PREFIX - Inner race description**

**E** ..... Inner race separable both directions.

**L** ..... Inner race separable one direction.

**LP** ..... Two piece inner race, one part is separable one direction, the other is a thrust plate to form a channeled race assembly.

**U** ..... Inner race with two flanges, non-separable.

**UM** ..... Inner race with two flanges, non-separable, full complement of rollers.

**NONE** ... No inner race supplied.

#### **SIZE DESIGNATOR**

Available Series; 1000, 1200, 1300, 5200, 5300 and 6200.

#### **SUFFIX - Outer race description**

**E (EMR)** ..... Outer race separable both directions.

**L (LMR)** ..... Outer race separable one direction.

**LP (LPMR)** ... Two piece outer race, one part is separable one direction, the other a thrust plate to form a channeled race assembly.

**U (UMR)** ..... Outer race with two flanges, non-separable.

**B** ..... Outer race with two snap rings to retain the roller set, non-separable.

**J** ..... Outer race with one snap ring and one flange to retain the roller set, non-separable.

#### **VARIATION CODES** - Variation codes are divided into two categories; **Special** and **Standard**.

##### **Special variation codes...**

**101 to 129** are numerically assigned codes that designate the variation from standard (example 101 = 1st variation, 102 = 2nd variation, etc.). These bearing code numbers do not in any way reference the modification from standard. Engineering must be contacted for information concerning a particular modification.

##### **Standard variation codes...**

**001 to 099 & 130 to 199** are code numbers representing standard modifications. The most popular are listed below:

- **K** - Over sized OD.
- **003** - Rollway internal clearance Class 3.
- **005** - Rollway internal clearance Class 5.
- **007** - Rollway internal clearance Class 7.
- **019** - Outer race with SAE ring groove around OD.
- **027** - Outer race with blind hole or locating slot in outer race.
- **191** - Broached retainer.
- **199** - Bearing with SAE ring groove on OD and snap ring furnished.



#### MAX Numbering

This system for radial bearings is broken into 3 parts; **Prefix**, **Size Designator** and **Variation code**.

Example:

**MCS-5222-103**

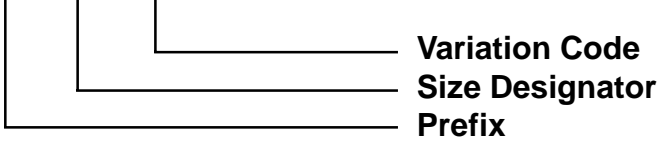

#### PREFIX - Bearing configuration description

**ML** ..... Bearing assembly with roller assembly retained in inner race, outer race separable one direction.

**MCS** ..... Bearing assembly with roller assembly retained in inner race, outer race separable both directions.

**MN** ..... Bearing assembly with roller assembly retained in inner race. Two piece outer race, one part is separable one direction, the other is a thrust plate to form a channel race.

**MS** ..... Bearing assembly with roller assembly retained in inner race. Outer race with two snap rings to retain the roller set, non-separable.

**M** ..... Bearing assembly with roller assembly retained in inner race. Outer race with two snap rings to retain the roller set, non-separable with a full complement of rollers.

**MUC** ..... Bearing assembly with inner race separable both directions. Roller assembly retained in outer race.

**MUL** ..... Bearing assembly with inner race separable one direction. Roller assembly retained in outer race.

**MU** ..... Bearing with a two piece inner race, one part is separable one direction, the other is a thrust plate to form a channeled race. Outer race retains the roller assembly.

**MR** ..... Bearing with a two piece inner race, one part is separable one direction, the other is an HJ ring to form a channel race. Outer race retains the roller assembly.

#### SIZE DESIGNATOR

Available Series; 100, 200, 300, 5000 and 5100.

**VARIATION CODES** - Variation codes are divided into two categories; **Special** and **Standard**.

##### Special variation codes...

**101 to 199** are numerically assigned codes that designate the numerical variation from standard (example 101 = 1st variation, 102 = 2nd variation, etc.). These bearing code numbers do not in any way reference the modification from standard. Engineering must be contacted for information concerning a particular modification.

##### Standard variation codes...

**001 to 099** are code numbers representing standard modifications. The most popular are listed below:

- **003** - Rollway internal clearance Class 3.
- **005** - Rollway internal clearance Class 5.
- **007** - Rollway internal clearance Class 7.



### ISO Numbering

This system for radial bearings is broken into 3 parts; **Prefix**, **Size Designator** and **Variation code**.

Example:

**NU-320-EMC3**

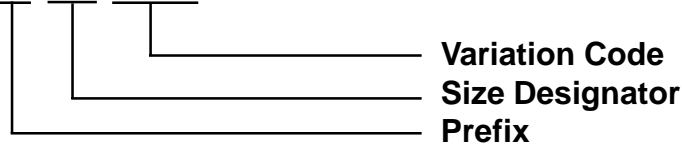

### PREFIX - Bearing configuration description

**NU** ..... Bearing assembly with inner race separable both directions. Roller assembly retained in outer race.

**NUP** ..... Bearing with a two piece inner race, one part is separable one direction, the other is a thrust plate to form a channeled race. Outer race retains the roller assembly.

**NJ** ..... Bearing assembly with inner race separable one direction. Roller assembly retained in outer race.

**N** ..... Bearing assembly with roller assembly retained in inner race. Outer race separable both directions.

### SIZE DESIGNATOR

Available Series; 200, 300, 2200 and 2300.

**VARIATION CODES** - Variation codes are divided into two categories; **Special** and **Standard**.

#### Special variation codes...

**VAA** begins an alpha code assigned to designate the variation from standard (example VAA = 1st variation, VAB = 2nd variation, etc.). These bearing codes do not in any way reference the modification from standard. Engineering must be contacted for information concerning a particular modification.

#### Standard variation codes...

Are code numbers representing standard modifications. The most popular are listed below:

- **E** - Extra capacity design.
- **M** - Machined brass retainer.
- **C2** - ABMA internal clearance symbol 2.
- **C3** - ABMA internal clearance symbol 3.
- **C4** - ABMA internal clearance symbol 4.
- **S1** - Bearing is stabilized for operation at 390°F.

#### ***Stamped Steel Retainer...***

A one-piece, low carbon steel stamping. Supplied on some bearings with snap ring detention. (TRU-ROL numbering suffix of "B") Recommended for low speed operations.



#### ***Segmented Steel Retainer...***

A built-up type of retainer utilizing low carbon steel segments rigidly held between stamped, low carbon steel end plates. This is the standard retainer supplied with commercial bearings identified with the TRU-ROL numbering system. Recommended for moderate speed applications.

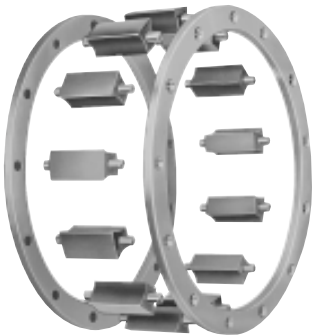

#### ***Two-Piece Retainer...***

This type of retainer is fabricated from brass. This is the standard retainer supplied with ROLLWAY bearings identified with the MAX numbering system, ISO numbering system, TRU-ROL numbering system when the "MR" suffix is used, and any bearing with bore size over 180mm. Recommended for moderate to high speed applications.



#### ***One Piece Retainer...***

This land piloting retainer is fabricated from brass or steel with radial retention of the rollers provided by closing the roller "pocket" with small projections formed by mechanically upsetting the retainer material. This retainer design is typically made to order for high speed applications, though it is applicable for other applications.



It should be noted that retainers may be designed for specific applications to enhance bearing performance. Please contact Engineering at 1-800-448-2260 for more information.



# ROLLWAY®

## RADIAL ROLLER BEARINGS

### SERIES CODE & RACE AND ROLLER MATERIAL

#### ***Radial Roller Bearing Series Codes...***

The ABMA has established standard design criteria for radial roller bearings. It has defined standard series for the roller bearings by identifying the outside diameter and width for a given bore diameter. The illustration below demonstrates the differences in cross section for the given series.

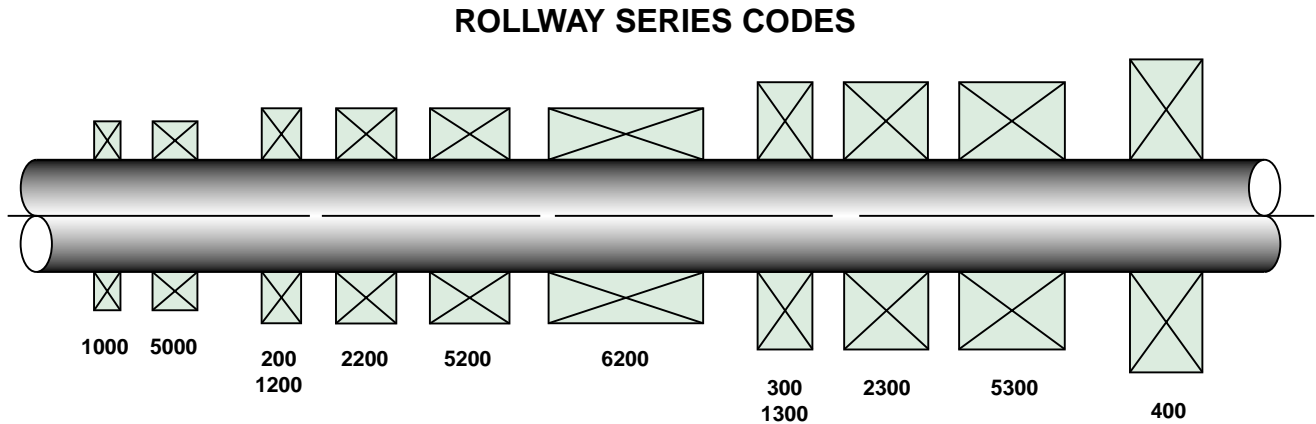

#### ***Race and Roller Material...***

The races and rollers in standard ROLLWAY bearings are made of vacuum-degassed, high alloy, through-hardened and/or case-carburized steels that are stabilized for operation up to 250°F for case-carburized steel and 335°F for through hardened steels. For operating temperatures in excess of 335°F, special materials and/or stabilization procedures are necessary.

Vacuum-degassed steels are used in standard bearings; however, consumable-electrode remelted steels (from either air CEVM or vacuum-melted electrodes VIMVAR) are available in all alloys and will be supplied upon request.

We also has the capability to manufacture in low quantity any bearing design with M-50 tool steel for applications requiring high temperature hardness, and average operating temperatures over 400°F but less than 800°F.



### ***Class of Precision...***

Standard catalog radial roller bearings are manufactured to the ABMA RBEC-1 tolerance class. Many applications may require greater precision than standard because of high rotational speeds or other exacting requirements. Bearings manufactured to either RBEC-3, RBEC-5 or special tolerance classes are also available upon request.

***Tolerance limits for the three RBEC classes are given in the Engineering section.***

### ***Basics of Load Ratings and Bearing Selection Criteria...***

The Engineering Data section of this catalog provides information useful to the designer for the proper sizing and configuration of bearings, and the means for predicting expected life under specific application conditions. The capacities in the following sections have been calculated in accordance with the ABMA standards.

All ROLLWAY bearings are made with *crowned rollers* which satisfy the general requirements for modified-line contact, in accordance with ABMA definitions.

The ROLLWAY *crowning technique* is a highly developed technology including analytical, experimental, processing and quality control techniques to ensure the following:

1. Freedom from end effects and stress concentrations under *design* load conditions.
2. Detailed understanding and the necessary controls for demanding applications where reliability and higher theoretical capacities are essential.

The control of crown modifications has long been taken for granted as a qualitative feature of rolling contact bearings but here, it is a highly developed capability by which optimum quantitative results are produced in the actual application.

In the following sections, specific reference is made to the recognition and accommodation of misalignment. Also provided are detailed methods for determining the life improvement due to modern materials and processing, as well as life limitation due to application designs and operating conditions.

### ***Limiting Speed...***

The limiting speed of a roller bearing is the rotational speed at which it may be operated based on geometry, retainer construction, lubricant and lubrication method without incurring a temperature rise within the bearing which would cause lubricant breakdown, softening of components or seizure. The criterion used is the  $dn$  value where  $d$  equals the bearing bore diameter (mm) and  $n$  equals the bearing rotation speed (rpm).

The graph on page 13 provides the suggested safe limiting speeds for cylindrical radial roller bearings with various types of retainer construction based on recirculating oil lubrication with a lubricant of adequate viscosity.

In the selection of a retainer design for obtaining the highest practical roller bearing operating speed, it is often necessary to consider other factors than speed alone. For example, a two-piece drilled retainer might be selected over a segmented retainer where the torsional loading on the retainer is severe even though the segmented type appears adequate with respect to speed.

It should be noted that suggested limiting speeds are given graphically for the standard roller-riding retainers (segmented, two-piece drilled and window-type stamped steel) and one-piece broached and piloting retainers. Special retainer designs for each of these types permit higher operating speeds and are available upon request.

When using the graph, these guidelines should be followed:

1. For grease lubricant applications, use 80% of the suggested limiting speed.
2. For air-oil mist lubricant applications, use 150% of the suggested limiting speed.
3. For fixed volume of non-recirculated oil, use 85% of the suggested limiting speed.
4. For double width and multi-row designs, use 67% of the suggested limiting speed.



### LIMITING SPEED GRAPH

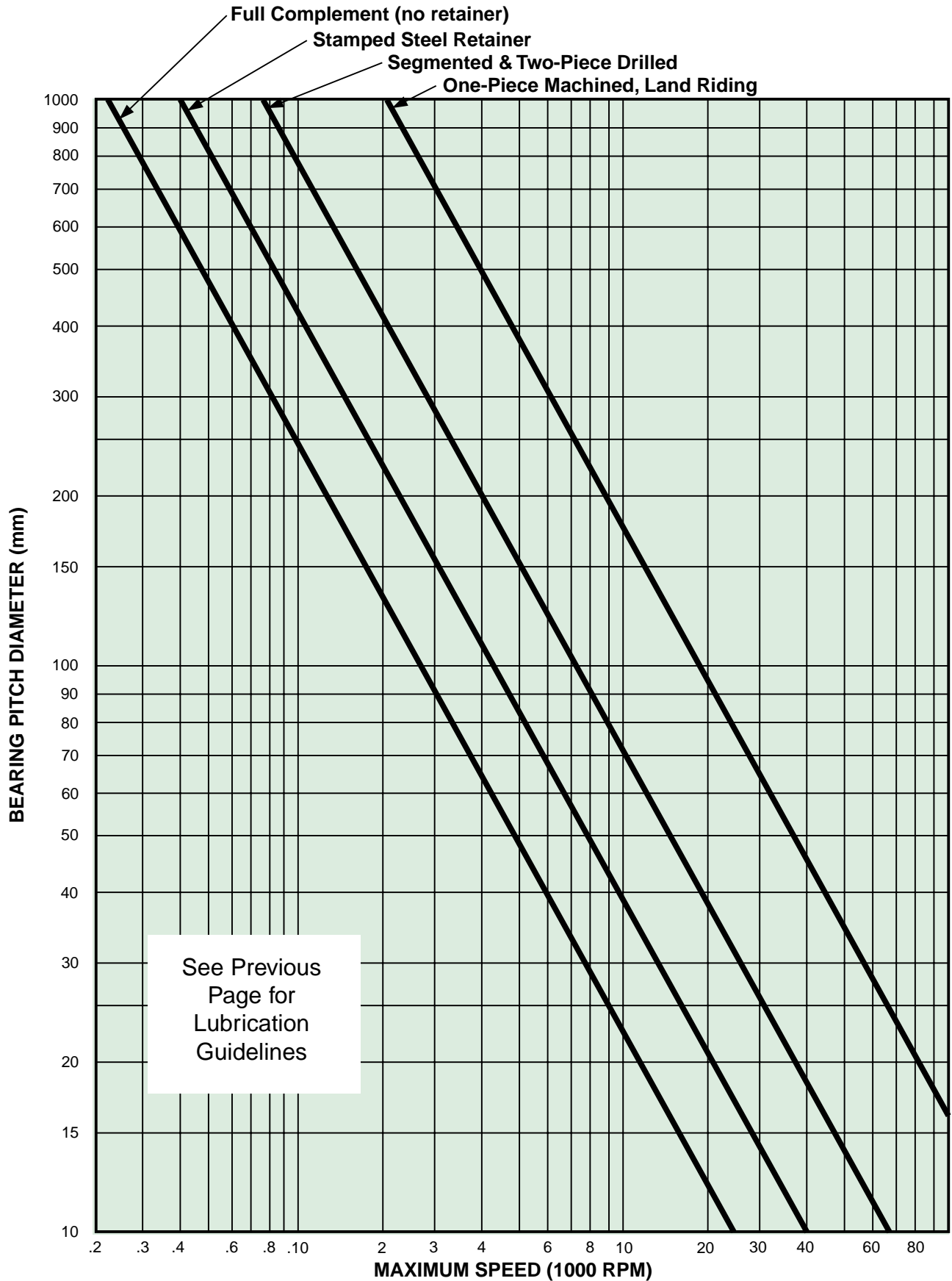



## CYLINDRICAL RADIAL ROLLER BEARINGS

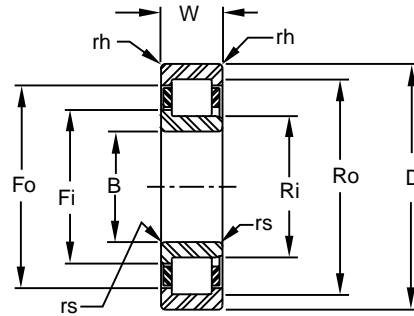

BORE		OUTSIDE DIAMETER		WIDTH		RADIUS		BASIC DYNAMIC CAPACITY	BASIC STATIC CAPACITY	FLANGE O.D. INNER RACE	O.D. INNER RACE	FLANGE I.D. OUTER RACE	I.D. OUTER RACE
B		D		W		rs	rh	POUNDS	POUNDS	Fi	Ri	Fo	Ro
MM	INCH	MM	INCH	MM	INCH	MM	MM			MM			
30	1.1811	62	2.4409	16.0	0.6299	1.0	1.0	7,130	6,920	41.3	38.0	51.2	54.0
	1.1811	62	2.4409	23.8	0.9375	1.0	1.0	10,610	11,530	41.3	38.0	51.2	54.0
	1.1811	72	2.8346	19.0	0.7480	1.5	1.0	9,930	9,510	44.6	40.7	56.9	60.4
	1.1881	72	2.8346	30.2	1.1875	1.5	1.0	15,830	17,340	44.6	40.7	56.9	60.4
35	1.3780	72	2.8346	17.0	0.6693	1.0	1.0	8,550	8,280	48.0	44.0	59.4	62.4
	1.3780	72	2.8346	27.0	1.0625	1.0	1.0	13,960	15,570	48.0	44.0	59.4	62.4
	1.3780	72	2.8346	54.0	2.1250	1.0	1.0	23,930	31,130	48.0	44.0	59.4	62.4
	1.3780	80	3.1496	21.0	0.8268	1.5	1.0	14,990	14,820	51.2	46.2	65.4	70.2
	1.3780	80	3.1496	21.0	0.8268	1.5	1.5	12,980	13,300	51.1	46.8	64.2	67.9
	1.3780	80	3.1496	34.9	1.3750	1.5	1.5	19,620	22,640	51.1	46.8	64.2	67.9
40	1.5748	80	3.1496	18.0	0.7087	1.5	1.0	10,320	10,470	53.4	49.9	66.1	69.6
	1.5748	80	3.1496	30.2	1.1875	1.5	1.0	17,700	20,950	53.4	49.9	66.1	69.6
	1.5748	90	3.5433	23.0	0.9055	1.5	1.5	18,500	18,210	57.7	52.0	74.4	80.0
	1.5748	90	3.5433	23.0	0.9055	1.5	1.5	15,620	15,500	57.4	52.6	73.1	77.9
	1.5748	90	3.5433	36.5	1.4375	1.5	1.5	24,670	27,900	57.4	52.6	73.1	77.9
45	1.7717	85	3.3465	19.0	0.7480	1.5	1.0	14,190	15,060	59.1	54.5	72.1	76.5
	1.7717	85	3.3465	19.0	0.7480	1.5	1.0	11,480	12,400	59.4	55.5	71.5	74.9
	1.7717	85	3.3465	30.2	1.1875	1.5	1.0	18,310	22,600	59.4	55.5	71.5	74.9
	1.7717	86	3.3970	39.7	1.5625	2.0	1.5	30,580	36,580	64.8	59.4	81.3	86.1
	1.7717	97	3.8125	25.0	0.9843	1.5	1.5	22,380	22,900	64.6	58.5	82.5	88.5
	1.7717	97	3.8125	25.0	0.9843	2.0	1.5	19,710	20,800	64.8	59.4	81.3	86.1
50	1.9685	90	3.5433	20.0	0.7874	1.5	1.0	14,850	16,300	64.1	59.5	0.0	81.5
	1.9685	90	3.5433	20.0	0.7874	1.5	1.0	11,700	13,160	64.4	60.5	76.7	79.5
	1.9685	90	3.5433	30.2	1.1875	1.5	1.0	18,660	23,980	64.4	60.5	76.7	79.5
	1.9685	90	3.5433	60.3	2.3750	1.5	1.0	32,000	47,960	64.4	60.5	76.7	79.5
	1.9685	110	4.3307	27.0	1.0630	2.0	2.0	25,270	26,290	71.4	65.0	90.6	97.0
	1.9685	110	4.3307	27.0	1.0630	2.0	2.0	22,950	24,410	71.0	65.2	89.2	94.5
	1.9685	110	4.3307	40.0	1.5748	2.0	2.0	37,000	42,930	71.4	65.0	90.6	97.0
	1.9685	110	4.3307	44.5	1.7500	2.0	2.0	36,090	43,690	71.0	65.2	89.2	94.5
55	2.1654	100	3.9370	21.0	0.8268	2.0	1.5	19,410	22,380	70.9	66.0	85.2	90.0
	2.1654	100	3.9370	21.0	0.8268	2.0	1.5	14,580	16,840	71.1	66.9	84.2	88.0
	2.1654	100	3.9370	33.3	1.3125	2.0	1.5	23,630	31,330	71.1	66.9	84.2	88.0
	2.1654	120	4.7244	29.0	1.1417	2.0	2.0	31,150	32,700	77.6	70.5	99.3	106.5
	2.1654	120	4.7244	29.0	1.1417	2.0	2.0	25,960	27,620	77.9	71.4	97.8	103.6
	2.1654	120	4.7244	43.0	1.6929	2.0	2.0	45,440	53,140	77.6	70.5	99.3	106.5
	2.1654	120	4.7244	49.2	1.9375	2.0	2.0	44,510	55,140	77.9	71.4	97.8	103.6

Notes:

1. Some configurations may not be in production, check for availability
2. Actual retainer options may vary, check for retainer design availability
3. Corners rs & rh are the maximum shaft and housing fillet radius that can be cleared

## CYLINDRICAL RADIAL ROLLER BEARINGS

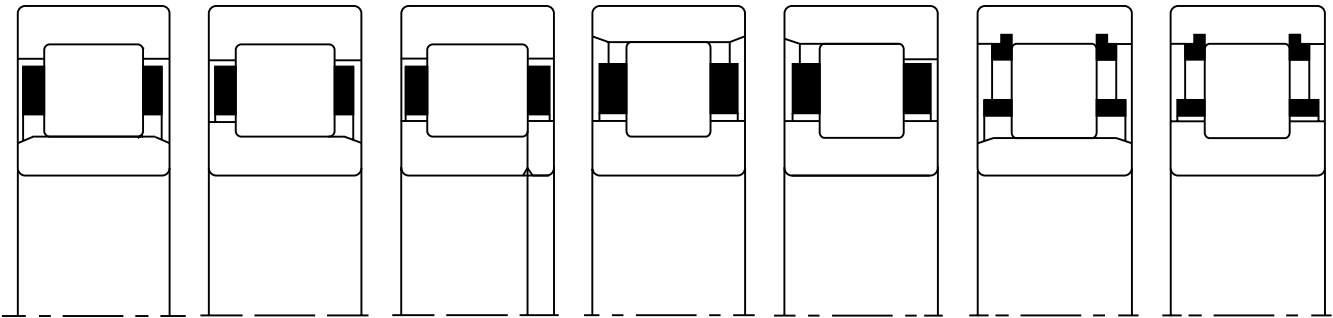

INNER RACE SEPARABLE BOTH DIRECTIONS	INNER RACE SEPARABLE ONE DIRECTION	TWO PIECE INNER RACE FOUR FLANGE DESIGN	OUTER RACE SEPARABLE BOTH DIRECTIONS	OUTER RACE SEPARABLE ONE DIRECTION	INNER RACE SEPARABLE BOTH DIRECTIONS	NONSEPARABLE
E 1206 U	L 1206 U	LP 1206 U	U 1206 E	U 1206 L	E 1206 B	U 1206 B
E 5206 U	L 5206 U	LP 5206 U	U 5206 E	U 5206 L	E 5206 B	U 5206 B
E 1306 U	L 1306 U	LP 1306 U	U 1306 E	U 1306 L	E 1306 B	U 1306 B
E 5306 U	L 5306 U	LP 5306 U	U 5306 E	U 5306 L	E 5306 B	U 5306 B
E 1207 U	L 1207 U	LP 1207 U	U 1207 E	U 1207 L	E 1207 B	U 1207 B
E 5207 U	L 5207 U	LP 5207 U	U 5207 E	U 5207 L	E 5207 B	U 5207 B
-	-	-	-	-	E 6207 B	-
NU 307 E	NJ 307 E	NUP 307 E	N 307 E	-	-	-
E 1307 U	L 1307 U	LP 1307 U	U 1307 E	U 1307 L	E 1307 B	U 1307 B
E 5307 U	L 5307 U	LP 5307 U	U 5307 E	U 5307 L	E 5307 B	U 5307 B
E 1208 U	L 1208 U	LP 1208 U	U 1208 E	U 1208 L	E 1208 B	U 1208 B
E 5208 U	L 5208 U	LP 5208 U	U 5208 E	U 5208 L	E 5208 B	U 5208 B
NU 308 E	NJ 308 E	NUP 308 E	N 308 E	-	-	-
E 1308 U	L 1308 U	LP 1308 U	U 1308 E	U 1308 L	E 1308 B	U 1308 B
E 5308 U	L 5308 U	LP 5308 U	U 5308 E	U 5308 L	E 5308 B	U 5308 B
NU 209 E	NJ 209 E	NUP 209 E	N 209 E	-	-	-
E 1209 U	L 1209 U	LP 1209 U	U 1209 E	U 1209 L	E 1209 B	U 1209 B
E 5209 U	L 5209 U	LP 5209 U	U 5209 E	U 5209 L	E 5209 B	U 5209 B
E 5309 U	L 5309 U	LP 5309 U	U 5309 E	U 5309 L	E 5309 B	U 5309 B
NU 306 E	NJ 306 E	NUP 306 E	N 306 E	-	-	-
E 1309 U	L 1309 U	LP 1309 U	U 1309 E	U 1309 L	E 1309 B	U 1309 B
NU 210 E	NJ 210 E	NUP 210 E	N 210 E	-	-	-
E 1210 U	L 1210 U	LP 1210 U	U 1210 E	U 1210 L	E 1210 B	U 1210 B
E 5210 U	L 5210 U	LP 5210 U	U 5210 E	U 5210 L	E 5210 B	U 5210 B
-	-	-	-	-	E 6210 B	-
NU 310 E	NJ 310 E	NUP 310 E	N 310 E	-	-	-
E 1310 U	L 1310 U	LP 1310 U	U 1310 E	U 1310 L	E 1310 B	U 1310 B
NU 2310 E	NJ 2310 E	NUP 2310 E	N 2310 E	-	-	-
E 5310 U	L 5310 U	LP 5310 U	U 5310 E	U 5310 L	E 5310 B	U 5310 B
NU 211 E	NJ 211 E	NUP 211 E	N 211 E	-	-	-
E 1211 U	L 1211 U	LP 1211 U	U 1211 E	U 1211 L	E 1211 B	U 1211 B
E 5211 U	L 5211 U	LP 5211 U	U 5211 E	U 5211 L	E 5211 B	U 5211 B
NU 311 E	NJ 311 E	NUP 311 E	N 311 E	-	-	-
E 1311 U	L 1311 U	LP 1311 U	U 1311 E	U 1311 L	E 1311 B	U 1311 B
NU 2311 E	NJ 2311 E	NUP 2311 E	N 2311 E	-	-	-
E 5311 U	L 5311 U	LP 5311 U	U 5311 E	U 5311 L	E 5311 B	U 5311 B



**ROLLWAY**

**RADIAL ROLLER BEARINGS**

**CYLINDRICAL RADIAL ROLLER BEARINGS**

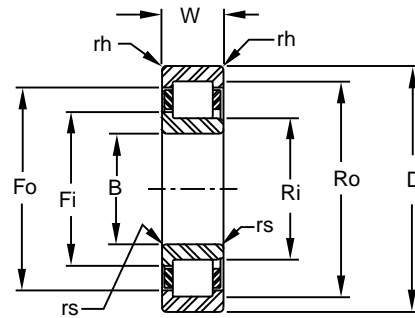

BORE	OUTSIDE DIAMETER		WIDTH		RADIUS		BASIC DYNAMIC CAPACITY	BASIC STATIC CAPACITY	FLANGE O.D. INNER RACE	O.D. INNER RACE	FLANGE I.D. OUTER RACE	I.D. OUTER RACE												
													B		D		W		rs	rh	Fi	Ri	Fo	Ro
													MM	INCH	MM	INCH	MM	INCH	MM	MM	MM	MM	MM	MM
60	2.3622	110	4.3307	22.0	0.8661	1.5	1.5	21,680	23,940	77.7	72.0	94.4	100.0											
	2.3622	110	4.3307	22.0	0.8661	2.0	1.5	18,040	20,080	76.9	72.4	93.2	97.7											
	2.3622	110	4.3307	36.5	1.4375	2.0	1.5	30,400	39,290	76.9	72.4	93.2	97.7											
	2.3622	110	4.3307	73.0	2.8750	2.0	1.5	52,120	78,570	76.9	72.4	93.2	97.7											
	2.3622	130	5.1181	31.0	1.2205	2.0	2.0	34,500	36,730	84.5	77.0	107.4	115.0											
	2.3622	130	5.1181	31.0	1.2205	2.5	2.0	30,240	32,570	84.6	77.5	106.3	112.4											
	2.3622	130	5.1181	46.0	1.8110	2.0	2.0	50,810	60,420	84.5	77.0	107.4	115.0											
	2.3622	130	5.1181	54.0	2.1250	2.5	2.0	53,440	67,710	84.6	77.5	106.3	112.4											
65	2.5591	120	4.7244	23.0	0.9055	1.5	1.5	24,730	27,720	84.6	78.5	102.5	108.5											
	2.5591	120	4.7244	23.0	0.9055	2.5	1.5	20,860	24,920	85.3	80.4	101.2	105.7											
	2.5591	120	4.7244	38.1	1.5000	2.5	1.5	20,860	24,920	85.3	80.4	101.2	105.7											
	2.5591	140	5.5118	33.0	1.2992	2.0	2.0	41,230	44,240	90.7	82.5	116.1	124.5											
	2.5591	140	5.5118	33.0	1.2992	2.5	2.0	35,720	39,080	90.7	82.5	114.7	120.2											
	2.5591	140	5.5118	48.0	1.8898	2.0	2.0	56,230	65,930	90.7	82.5	116.1	124.5											
	2.5591	140	5.5118	58.7	2.3125	2.5	2.0	65,530	81,950	90.7	82.5	114.7	120.2											
70	2.7559	125	4.9213	24.0	0.9449	1.5	1.5	24,820	28,140	89.4	83.5	107.2	113.5											
	2.7559	125	4.9213	24.0	0.9449	2.5	1.5	23,440	28,380	89.7	84.8	106.7	111.5											
	2.7559	125	4.9213	31.0	1.2205	1.5	1.5	24,820	28,140	89.4	83.5	107.2	113.5											
	2.7559	125	4.9213	39.7	1.5625	2.5	1.5	38,440	53,600	89.7	84.8	106.7	111.5											
	2.7559	125	4.9213	79.4	3.1250	2.5	1.5	65,900	107,190	89.7	84.8	106.7	111.5											
	2.7559	150	5.9055	35.0	1.3780	2.0	2.0	46,650	51,190	97.5	89.0	124.2	133.0											
	2.7559	150	5.9055	35.0	1.3780	3.2	2.0	43,250	49,040	97.3	89.2	122.2	129.3											
	2.7559	150	5.9055	51.0	2.0079	2.0	2.0	62,170	74,040	97.5	89.0	124.2	133.0											
	2.7559	150	5.9055	63.5	2.5000	3.2	2.0	70,550	92,000	97.3	89.2	122.2	129.3											
	75	2.9528	115	4.5276	20.0	0.7874	2.0	1.0	13,830	17,660	89.2	85.2	101.0	104.9										
2.9528		130	5.1181	25.0	0.9843	1.5	1.5	29,840	36,370	94.5	88.5	112.3	118.5											
2.9528		130	5.1181	25.0	0.9843	2.5	1.5	23,350	28,560	94.4	89.0	111.0	115.7											
2.9528		130	5.1181	31.0	1.2205	1.5	1.5	36,950	47,870	94.5	88.5	112.3	118.5											
2.9528		130	5.1181	41.3	1.6250	2.5	1.5	40,030	57,120	94.4	89.0	111.0	115.7											
2.9528		160	6.2992	37.0	1.4567	2.0	2.0	54,720	60,570	104.2	95.0	133.4	143.0											
2.9528		160	6.2992	37.0	1.4567	3.2	2.0	43,010	47,240	104.5	95.9	131.4	139.1											
2.9528		160	6.2992	55.0	2.1654	2.0	2.0	54,720	60,570	104.2	95.0	133.4	143.0											
2.9528		160	6.2992	68.3	2.6875	3.2	2.0	82,570	109,260	104.5	95.9	131.4	139.1											
80		3.1496	140	5.5118	26.0	1.0236	1.8	2.0	31,950	38,850	101.7	95.3	121.4	127.3										
	3.1496	140	5.5118	26.0	1.0236	2.5	2.0	25,480	30,670	101.7	95.3	119.4	124.6											
	3.1496	140	5.5118	33.0	1.2992	1.8	2.0	42,490	56,050	101.7	95.3	121.4	127.3											
	3.1496	140	5.5118	44.5	1.7500	2.5	2.0	45,290	64,230	101.1	95.3	119.4	124.6											
	3.1496	140	5.5118	88.9	3.5000	2.5	2.0	45,290	64,230	101.1	95.3	119.4	124.6											
	3.1496	170	6.6929	39.0	1.5354	2.0	2.0	59,020	65,950	110.6	101.0	141.0	151.0											
	3.1496	170	6.6929	39.0	1.5354	3.2	2.0	51,590	58,530	110.7	101.6	139.2	147.3											

Notes:

1. Some configurations may not be in production, check for availability
2. Actual retainer options may vary, check for retainer design availability
3. Corners rs & rh are the maximum shaft and housing fillet radius that can be cleared

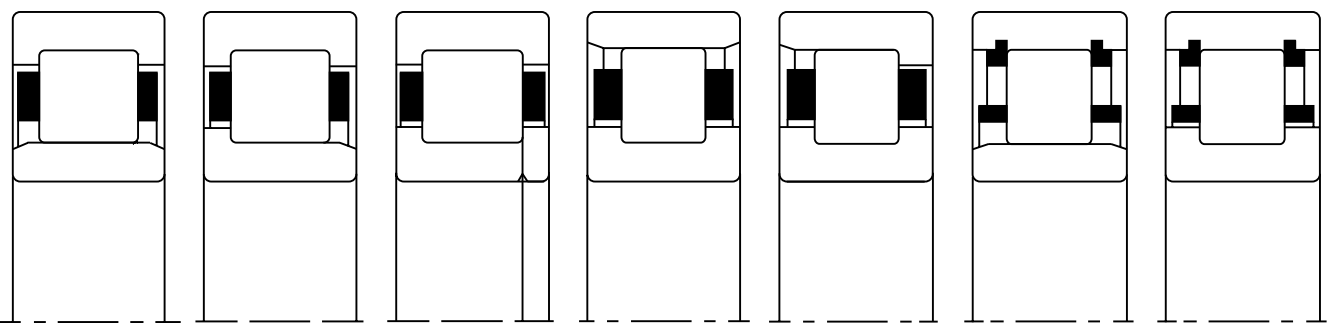

INNER RACE SEPARABLE BOTH DIRECTIONS	INNER RACE SEPARABLE ONE DIRECTION	TWO PIECE INNER RACE FOUR FLANGE DESIGN	OUTER RACE SEPARABLE BOTH DIRECTIONS	OUTER RACE SEPARABLE ONE DIRECTION	INNER RACE SEPARABLE BOTH DIRECTIONS	NONSEPARABLE
NU 212 E	NJ 212 E	NUP 212 E	N 212 E	-	-	-
E 1212 U	L 1212 U	LP 1212 U	U 1212 E	U 1212 L	E 1212 B	U 1212 B
E 5212 U	L 5212 U	LP 5212 U	U 5212 E	U 5212 L	E 5212 B	U 5212 B
-	-	-	-	-	E 6212 B	-
NU 312 E	NJ 312 E	NUP 312 E	N 312 E	-	-	-
E 1312 U	L 1312 U	LP 1312 U	U 1312 E	U 1312 L	E 1312 B	U 1312 B
NU 2312 E	NJ 2312 E	NUP 2312 E	N 2312 E	-	-	-
E 5312 U	L 5312 U	LP 5312 U	U 5312 E	U 5312 L	E 5312 B	U 5312 B
NU 213 E	NJ 213 E	NUP 213 E	N 213 E	-	-	-
E 1213 U	L 1213 U	LP 1213 U	U 1213 E	U 1213 L	E 1213 B	U 1213 B
E 5213 U	L 5213 U	LP 5213 U	U 5213 E	U 5213 L	E 5213 B	U 5213 B
NU 313 E	NJ 313 E	NUP 313 E	N 313 E	-	-	-
E 1313 U	L 1313 U	LP 1313 U	U 1313 E	U 1313 L	E 1313 B	U 1313 B
NU 2313 E	NJ 2313 E	NUP 2313 E	N 2313 E	-	-	-
E 5313 U	L 5313 U	LP 5313 U	U 5313 E	U 5313 L	E 5313 B	U 5313 B
NU 214 E	NJ 214 E	NUP 214 E	N 214 E	-	-	-
E 1214 U	L 1214 U	LP 1214 U	U 1214 E	U 1214 L	E 1214 B	U 1214 B
NU 2214 E	NJ 2214 E	NUP 2214 E	N 2214 E	-	-	-
E 5214 U	L 5214 U	LP 5214 U	U 5214 E	U 5214 L	E 5214 B	U 5214 B
-	-	-	-	-	E 6214 B	-
NU 314 E	NJ 314 E	NUP 314 E	N 314 E	-	-	-
E 1314 U	L 1314 U	LP 1314 U	U 1314 E	U 1314 L	E 1314 B	U 1314 B
NU 2314 E	NJ 2314 E	NUP 2314 E	N 2314 E	-	-	-
E 5314 U	L 5314 U	LP 5314 U	U 5314 E	U 5314 L	E 5314 B	U 5314 B
E 1015 U	L 1015 U	LP 1015 U	U 1015 E	U 1015 L	-	-
NU 215 E	NJ 215 E	NUP 215 E	N 215 E	-	-	-
E 1215 U	L 1215 U	LP 1215 U	U 1215 E	U 1215 L	E 1215 B	U 1215 B
NU 2215 E	NJ 2215 E	NUP 2215 E	N 2215 E	-	-	-
E 5215 U	L 5215 U	LP 5215 U	U 5215 E	U 5215 L	E 5215 B	U 5215 B
NU 315 E	NJ 315 E	NUP 315 E	N 315 E	-	-	-
E 1315 U	L 1315 U	LP 1315 U	U 1315 E	U 1315 L	E 1315 B	U 1315 B
NU 2315 E	NJ 2315 E	NUP 2315 E	N 2315 E	-	-	-
E 5315 U	L 5315 U	LP 5315 U	U 5315 E	U 5315 L	E 5315 B	U 5315 B
NU 216 E	NJ 216 E	NUP 216 E	N 216 E	-	-	-
E 1216 U	L 1216 U	LP 1216 U	U 1216 E	U 1216 L	E 1216 B	U 1216 B
NU 2216 E	NJ 2216 E	NUP 2216 E	N 2216 E	-	-	-
E 5216 U	L 5216 U	LP 5216 U	U 5216 E	U 5216 L	E 5216 B	U 5216 B
-	-	-	-	-	E 6216 B	-
NU 316 E	NJ 316 E	NUP 316 E	N 316 E	-	-	-
E 1316 U	L 1316 U	LP 1316 U	U 1316 E	U 1316 L	E 1316 B	U 1316 B

## CYLINDRICAL RADIAL ROLLER BEARINGS

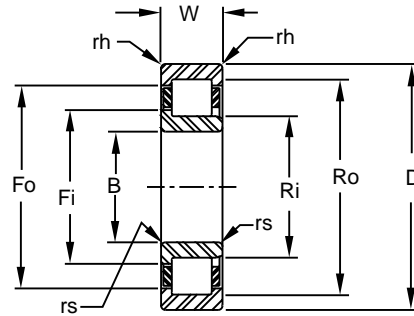

BORE		OUTSIDE DIAMETER		WIDTH		RADIUS		BASIC DYNAMIC CAPACITY	BASIC STATIC CAPACITY	FLANGE O.D. INNER RACE	O.D. INNER RACE	FLANGE I.D. OUTER RACE	I.D. OUTER RACE
B		D		W		rs	rh	POUNDS	POUNDS	Fi	Ri	Fo	Ro
MM	INCH	MM	INCH	MM	INCH	MM				MM			
80	3.1496	170	6.6929	58.0	2.2835	2.0	2.0	81,400	99,700	110.6	101.0	141.0	151.0
	3.1496	170	6.6929	68.3	2.6875	3.2	2.0	90,200	120,040	110.7	101.6	139.2	147.3
85	3.3465	130	5.1181	22.0	0.8661	2.0	1.0	20,120	27,290	100.8	96.3	113.9	118.7
	3.3465	150	5.9055	28.0	1.1024	2.0	2.0	37,930	45,530	107.6	100.5	129.3	136.5
	3.3465	150	5.9055	28.0	1.1024	3.2	2.0	31,040	37,940	108.5	102.0	128.4	134.1
	3.3465	150	5.9055	36.0	1.4173	2.0	2.0	49,220	63,640	107.6	100.5	129.3	136.5
	3.3465	150	5.9055	49.2	1.9375	3.2	2.0	55,960	80,940	108.5	102.0	128.4	134.1
	3.3465	180	7.0866	41.0	1.6142	2.5	2.5	63,470	71,680	118.0	108.0	149.6	160.0
	3.3465	180	7.0866	41.0	1.6142	4.0	2.5	52,360	58,040	118.2	108.5	148.6	157.3
	3.3465	180	7.0866	60.0	2.3622	2.5	2.5	84,940	104,260	118.0	108.0	149.6	160.0
	3.3465	180	7.0866	73.0	2.8750	4.0	2.5	100,450	134,110	118.2	108.5	148.6	157.3
90	3.5433	160	6.2992	30.0	1.1811	2.0	2.0	41,950	50,850	114.5	107.0	137.4	145.0
	3.5433	160	6.2992	30.0	1.1811	3.2	2.0	36,400	44,770	114.2	107.2	135.9	142.1
	3.5433	160	6.2992	40.0	1.5748	2.0	2.0	55,410	72,730	114.5	107.0	137.4	145.0
	3.5433	160	6.2992	52.4	2.0625	3.2	2.0	64,800	93,990	114.2	107.2	135.9	142.1
	3.5433	190	7.4803	43.0	1.6929	2.5	2.5	71,900	81,460	124.2	113.5	158.3	169.5
	3.5433	190	7.4803	43.0	1.6929	4.0	2.5	65,930	76,800	123.4	114.0	156.2	165.3
	3.5433	190	7.4803	64.0	2.5197	2.5	2.5	98,570	122,210	124.2	113.5	158.3	169.5
	3.5433	190	7.4803	73.0	2.8750	4.0	2.5	109,420	147,290	123.4	114.0	156.2	165.3
95	3.7402	170	6.6929	32.0	1.2598	2.0	2.0	48,060	57,570	120.7	112.5	146.1	154.5
	3.7402	170	6.6929	32.0	1.2598	3.2	2.0	42,800	53,330	121.0	113.5	144.5	151.2
	3.7402	170	6.6929	43.0	1.6929	2.0	2.0	62,170	80,150	120.7	112.5	146.1	154.5
	3.7402	170	6.6929	55.6	2.1875	3.2	2.0	74,750	109,230	121.0	113.5	144.5	151.2
	3.7402	170	6.6929	111.1	4.3750	3.2	2.0	128,160	218,460	121.0	113.5	144.5	151.2
	3.7402	200	7.8740	45.0	1.7717	3.0	2.5	76,090	88,880	132.2	121.5	166.3	177.5
	3.7402	200	7.8740	45.0	1.7717	4.0	2.5	62,320	72,200	132.5	122.1	164.3	173.4
	3.7402	200	7.8740	67.0	2.6378	3.0	2.5	104,300	133,340	132.2	121.5	166.3	177.5
	3.7402	200	7.8740	77.8	3.0625	4.0	2.5	103,420	138,460	132.5	122.1	164.3	173.4
100	3.9370	180	7.0866	34.0	1.3386	2.0	2.0	54,310	66,320	127.5	119.0	0.0	163.0
	3.9370	180	7.0866	34.0	1.3386	4.0	2.0	46,820	58,420	129.0	121.0	154.2	161.1
	3.9370	180	7.0866	46.0	1.8110	2.0	2.0	72,370	95,930	127.5	119.0	0.0	163.0
	3.9370	180	7.0866	60.3	2.3750	4.0	2.0	84,220	124,280	129.0	121.0	154.2	161.1
	3.9370	180	7.0866	120.7	4.7500	4.0	2.0	144,400	248,570	129.0	121.0	154.2	161.1
	3.9370	215	8.4646	47.0	1.8504	2.5	2.5	87,520	99,400	139.6	127.5	178.7	191.5
	3.9370	215	8.4646	47.0	1.8504	4.7	2.5	68,220	79,160	141.1	130.2	175.1	184.8
	3.9370	215	8.4646	73.0	2.8740	2.5	2.5	130,230	165,680	139.6	127.5	178.7	191.5
	3.9370	215	8.4646	82.6	3.2500	4.7	2.5	123,110	169,100	141.1	130.2	175.1	184.8
	105	4.1339	160	6.2992	26.0	1.0236	2.5	2.0	29,630	42,300	124.5	119.2	140.6
4.1339		190	7.4803	36.0	1.4173	4.0	2.0	52,740	67,070	134.9	126.5	161.0	168.5
4.1339		190	7.4803	65.1	2.5625	4.0	2.0	98,710	150,150	134.9	126.5	161.0	168.5

Notes:

1. Some configurations may not be in production, check for availability
2. Actual retainer options may vary, check for retainer design availability
3. Corners rs & rh are the maximum shaft and housing fillet radius that can be cleared



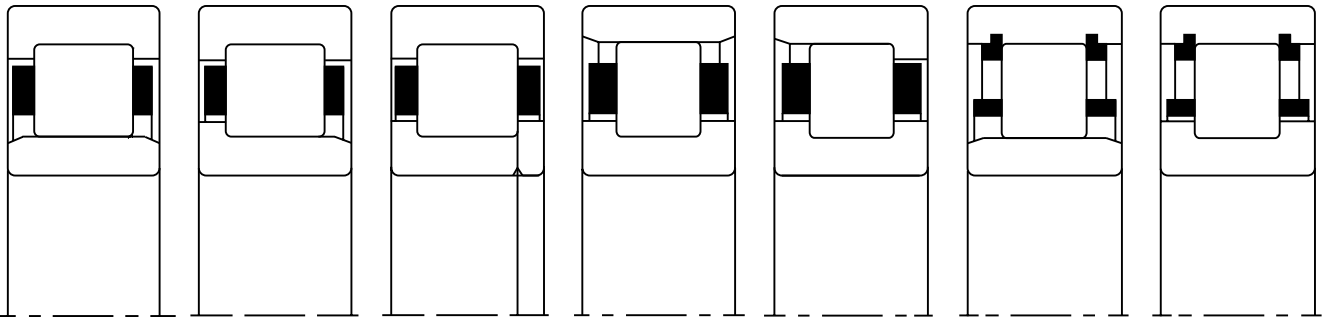

INNER RACE SEPARABLE BOTH DIRECTIONS	INNER RACE SEPARABLE ONE DIRECTION	TWO PIECE INNER RACE FOUR FLANGE DESIGN	OUTER RACE SEPARABLE BOTH DIRECTIONS	OUTER RACE SEPARABLE ONE DIRECTION	INNER RACE SEPARABLE BOTH DIRECTIONS	NONSEPARABLE
NU 2316 E	NJ 2316 E	NUP 2316 E	N 2316 E	-	-	-
E 5316 U	L 5316 U	LP 5316 U	U 5316 E	U 5316 L	E 5316 B	U 5316 B
E 1017 U	L 1017 U	LP 1017 U	U 1017 E	U 1017 L	-	-
NU 217 E	NJ 217 E	NUP 217 E	N 217 E	-	-	-
E 1217 U	L 1217 U	LP 1217 U	U 1217 E	U 1217 L	E 1217 B	U 1217 B
NU 2217 E	NJ 2217 E	NUP 2217 E	N 2217 E	-	-	-
E 5217 U	L 5217 U	LP 5217 U	U 5217 E	U 5217 L	E 5217 B	U 5217 B
NU 317 E	NJ 317 E	NUP 317 E	N 317 E	-	-	-
E 1317 U	L 1317 U	LP 1317 U	U 1317 E	U 1317 L	E 1317 B	U 1317 B
NU 2317 E	NJ 2317 E	NUP 2317 E	N 2317 E	-	-	-
E 5317 U	L 5317 U	LP 5317 U	U 5317 E	U 5317 L	E 5317 B	U 5317 B
NU 218 E	NJ 218 E	NUP 218 E	N 218 E	-	-	-
E 1218 U	L 1218 U	LP 1218 U	U 1218 E	U 1218 L	E 1218 B	U 1218 B
NU 2218 E	NJ 2218 E	NUP 2218 E	N 2218 E	-	-	-
E 5218 U	L 5218 U	LP 5218 U	U 5218 E	U 5218 L	E 5218 B	U 5218 B
NU 318 E	NJ 318 E	NUP 318 E	N 318 E	-	-	-
E 1318 U	L 1318 U	LP 1318 U	U 1318 E	U 1318 L	E 1318 B	U 1318 B
NU 2318 E	NJ 2318 E	NUP 2318 E	N 2318 E	-	-	-
E 5318 U	L 5318 U	LP 5318 U	U 5318 E	U 5318 L	E 5318 B	U 5318 B
NU 219 E	NJ 219 E	NUP 219 E	N 219 E	-	-	-
E 1219 U	L 1219 U	LP 1219 U	U 1219 E	U 1219 L	E 1219 B	U 1219 B
NU 2219 E	NJ 2219 E	NUP 2219 E	N 2219 E	-	-	-
E 5219 U	L 5219 U	LP 5219 U	U 5219 E	U 5219 L	E 5219 B	U 5219 B
-	-	-	-	-	E 6219 B	-
NU 319 E	NJ 319 E	NUP 319 E	N 319 E	-	-	-
E 1319 U	L 1319 U	LP 1319 U	U 1319 E	U 1319 L	E 1319 B	U 1319 B
NU 2319 E	NJ 2319 E	NUP 2319 E	N 2319 E	-	-	-
E 5319 U	L 5319 U	LP 5319 U	U 5319 E	U 5319 L	E 5319 B	U 5319 B
NU 220 E	NJ 220 E	NUP 220 E	N 220 E	-	-	-
E 1220 U	L 1220 U	LP 1220 U	U 1220 E	U 1220 L	E 1220 B	U 1220 B
NU 2220 E	NJ 2220 E	NUP 2220 E	N 2220 E	-	-	-
E 5220 U	L 5220 U	LP 5220 U	U 5220 E	U 5220 L	E 5220 B	U 5220 B
-	-	-	-	-	E 6220 B	-
NU 320 E	NJ 320 E	NUP 320 E	N 320 E	-	-	-
E 1320 U	L 1320 U	LP 1320 U	U 1320 E	U 1320 L	E 1320 B	U 1320 B
NU 2320 E	NJ 2320 E	NUP 2320 E	N 2320 E	-	-	-
E 5320 U	L 5320 U	LP 5320 U	U 5320 E	U 5320 L	E 5320 B	U 5320 B
E 1021 U	L 1021 U	LP 1021 U	U 1021 E	U 1021 L	-	-
E 1221 U	L 1221 U	LP 1221 U	U 1221 E	U 1221 L	E 1221 B	U 1221 B
E 5221 U	L 5221 U	LP 5221 U	U 5221 E	U 5221 L	E 5221 B	U 5221 B

## CYLINDRICAL RADIAL ROLLER BEARINGS

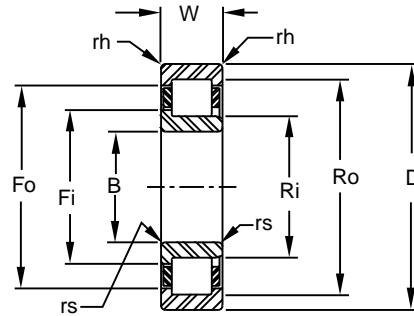

BORE		OUTSIDE DIAMETER		WIDTH		RADIUS		BASIC DYNAMIC CAPACITY	BASIC STATIC CAPACITY	FLANGE O.D. INNER RACE	O.D. INNER RACE	FLANGE I.D. OUTER RACE	I.D. OUTER RACE
B		D		W		rs	rh	POUNDS	POUNDS	Fi	Ri	Fo	Ro
MM	INCH	MM	INCH	MM	INCH	MM				MM			
105	4.1339	225	8.8583	49.0	1.9291	4.7	3.0	98,160	112,230	146.6	132.9	187.4	200.9
	4.1339	225	8.8583	49.0	1.9291	4.7	2.5	80,860	96,820	147.2	136.2	183.2	193.4
	4.1339	225	8.8583	87.3	3.4375	4.7	2.5	131,000	180,040	147.2	136.2	183.2	193.4
110	4.3307	170	6.6929	28.0	1.1024	2.5	2.0	35,740	51,470	130.8	125.3	149.0	154.7
	4.3307	200	7.8740	38.0	1.4961	2.0	2.0	66,640	84,000	141.7	132.5	170.9	180.5
	4.3307	200	7.8740	38.0	1.4961	4.0	2.0	54,200	68,940	141.6	132.9	168.4	176.1
	4.3307	200	7.8740	53.0	2.0866	2.0	2.0	87,050	118,430	141.7	132.5	170.9	180.5
	4.3307	200	7.8740	69.9	2.7500	4.0	2.0	98,430	148,440	141.6	132.9	168.4	176.1
	4.3307	240	9.4488	50.0	1.9685	2.5	2.5	98,340	113,870	155.8	143.0	197.4	211.0
	4.3307	240	9.4488	50.0	1.9685	4.7	2.5	91,630	111,510	157.5	145.3	195.4	206.3
	4.3307	240	9.4488	80.0	3.1496	2.5	2.5	145,610	188,610	155.8	143.0	197.4	211.0
	4.3307	240	9.4488	92.1	3.6250	4.7	2.5	170,820	248,370	157.5	145.3	195.4	206.3
115	4.5275	150	5.9055	53.0	2.0866	4.7	2.5	97,240	115,130	162.3	149.6	202.7	215.5
	4.5275	250	9.8425	53.0	2.0866	4.7	2.5	97,240	115,130	162.3	149.6	202.7	215.5
120	4.7244	180	7.0866	28.0	1.1024	3.2	2.0	34,330	49,790	141.2	135.2	158.9	164.5
	4.7244	180	7.0866	46.0	1.8110	3.2	2.0	53,990	89,140	141.2	135.2	158.9	164.5
	4.7244	215	8.4646	40.0	1.5748	2.0	2.0	77,210	98,460	153.4	143.5	185.1	195.5
	4.7244	215	8.4646	40.0	1.5748	4.7	2.0	63,890	84,070	154.3	145.1	182.7	190.9
	4.7244	215	8.4646	58.0	2.2835	2.0	2.0	107,490	150,660	153.4	143.5	185.1	195.5
	4.7244	215	8.4646	76.2	3.0000	4.7	2.0	124,410	198,060	154.3	145.1	182.7	190.9
	4.7244	260	10.2362	55.0	2.1654	2.5	2.5	120,370	140,640	168.7	154.0	214.8	230.0
	4.7244	260	10.2362	55.0	2.1654	6.4	2.5	97,160	116,130	170.2	157.0	211.2	223.0
	4.7244	260	10.2362	86.0	3.3858	2.5	2.5	179,680	235,410	168.7	154.0	214.8	230.0
	4.7244	260	10.2362	104.8	4.1250	6.4	2.5	190,370	275,740	170.2	157.0	211.2	223.0
130	5.1181	200	7.8740	33.0	1.2992	3.2	2.0	45,750	65,870	154.2	147.6	175.5	182.5
	5.1181	200	7.8740	52.0	2.0472	3.2	2.0	77,780	130,310	154.2	147.6	175.5	182.5
	5.1181	230	9.0551	40.0	1.5748	4.7	2.5	68,550	89,760	164.7	155.0	195.2	203.8
	5.1181	230	9.0551	64.0	2.5197	4.7	2.5	147,240	239,880	164.7	155.0	195.2	203.8
	5.1181	280	11.0236	58.0	2.2835	4.0	3.2	132,780	157,260	183.0	167.0	231.0	247.0
	5.1181	280	11.0236	58.0	2.2835	6.4	3.2	111,770	134,200	184.9	170.5	229.8	242.7
	5.1181	280	11.0236	93.0	3.6614	4.0	3.2	197,370	261,790	183.0	167.0	231.0	247.0
	5.1181	280	11.0236	111.1	4.3750	6.4	3.2	222,500	325,200	184.9	170.5	229.8	242.7
140	5.5118	210	8.2677	33.0	1.2992	4.0	2.0	43,960	63,550	164.3	157.6	185.6	192.4
	5.5118	210	8.2677	53.0	2.0866	4.0	2.0	74,740	125,720	164.3	157.6	185.6	192.4
	5.5118	220	8.6614	36.0	1.4173	2.0	2.0	44,430	61,230	169.4	161.9	192.9	200.0
	5.5118	220	8.6614	63.5	2.5000	2.0	2.0	92,040	156,150	169.4	161.9	192.9	200.0
	5.5118	250	9.8425	42.0	1.6535	4.7	2.5	76,930	100,870	179.1	168.5	211.8	221.5
	5.5118	250	9.8425	82.6	3.2500	4.7	2.5	150,540	238,650	179.1	168.5	211.8	221.5
	5.5118	300	11.8110	62.0	2.4409	4.0	4.0	140,420	171,760	196.0	180.0	247.2	260.0
	5.5118	300	11.8110	62.0	2.4409	7.9	3.2	124,750	151,480	197.0	181.7	244.3	258.0

Notes:

1. Some configurations may not be in production, check for availability
2. Actual retainer options may vary, check for retainer design availability
3. Corners rs & rh are the maximum shaft and housing fillet radius that can be cleared

## CYLINDRICAL RADIAL ROLLER BEARINGS

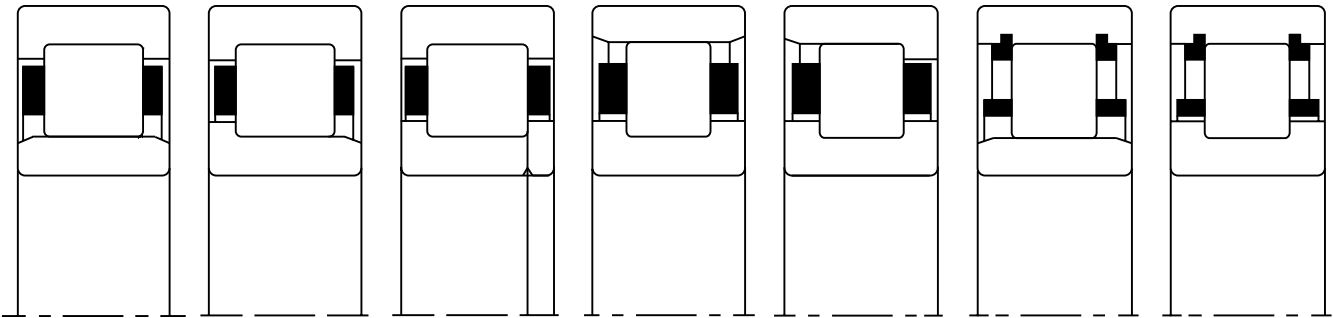

INNER RACE SEPARABLE BOTH DIRECTIONS	INNER RACE SEPARABLE ONE DIRECTION	TWO PIECE INNER RACE FOUR FLANGE DESIGN	OUTER RACE SEPARABLE BOTH DIRECTIONS	OUTER RACE SEPARABLE ONE DIRECTION	INNER RACE SEPARABLE BOTH DIRECTIONS	NONSEPARABLE
NU 321 E	NJ 321 E	NUP 321 E	N 321 E	-	-	-
E 1321 U	L 1321 U	LP 1321 U	U 1321 E	U 1321 L	E 1321 B	U 1321 B
E 5321 U	L 5321 U	LP 5321 U	U 5321 E	U 5321 L	E 5321 B	U 5321 B
E 1022 U	L 1022 U	LP 1022 U	U 1022 E	U 1022 L	-	-
NU 222 E	NJ 222 E	NUP 222 E	N 222 E	-	-	-
E 1222 U	L 1222 U	LP 1222 U	U 1222 E	U 1222 L	E 1222 B	U 1222 B
NU 2222 E	NJ 2222 E	NUP 2222 E	N 2222 E	-	-	-
E 5222 U	L 5222 U	LP 5222 U	U 5222 E	U 5222 L	E 5222 B	U 5222 B
NU 322 E	NJ 322 E	NUP 322 E	N 322 E	-	-	-
E 1322 U	L 1322 U	LP 1322 U	U 1322 E	U 1322 L	E 1322 B	U 1322 B
NU 2322 E	NJ 2322 E	NUP 2322 E	N 2322 E	-	-	-
E 5322 U	L 5322 U	LP 5322 U	U 5322 E	U 5322 L	E 5322 B	U 5322 B
NU 323	NJ 323	NUP 323	N 323	-	-	-
E 1323 U	L 1323 U	LP 1323 U	U 1323 E	U 1323 L	E 1323 B	U 1323 B
E 1024 U	L 1024 U	LP 1024 U	U 1024 E	U 1024 L	-	-
E 5024 U	L 5024 U	LP 5024 U	U 5024 E	U 5024 L	E 5024 B	U 5024 B
NU 224 E	NJ 224 E	NUP 224 E	N 224 E	-	-	-
E 1224 U	L 1224 U	LP 1224 U	U 1224 E	U 1224 L	E 1224 B	U 1224 B
NU 2224 E	NJ 2224 E	NUP 2224 E	N 2224 E	-	-	-
E 5224 U	L 5224 U	LP 5224 U	U 5224 E	U 5224 L	E 5224 B	U 5224 B
NU 324 E	NJ 324 E	NUP 324 E	N 324 E	-	-	-
E 1324 U	L 1324 U	LP 1324 U	U 1324 E	U 1324 L	E 1324 B	U 1324 B
NU 2324 E	NJ 2324 E	NUP 2324 E	N 2324 E	-	-	-
E 5324 U	L 5324 U	LP 5324 U	U 5324 E	U 5324 L	E 5324 B	U 5324 B
E 1026 U	L 1026 U	LP 1026 U	U 1026 E	U 1026 L	-	-
E 5026 U	L 5026 U	LP 5026 U	U 5026 E	U 5026 L	-	-
E 1226 U	L 1226 U	LP 1226 U	U 1226 E	U 1226 L	E 1226 B	U 1226 B
E 5226 U	L 5226 U	LP 5226 U	U 5226 E	U 5226 L	E 5226 B	U 5226 B
NU 326 E	NJ 326 E	NUP 326 E	N 326 E	-	-	-
E 1326 U	L 1326 U	LP 1326 U	U 1326 E	U 1326 L	-	-
NU 2326 E	NJ 2326 E	NUP 2326 E	N 2326 E	-	-	-
E 5326 U	L 5326 U	LP 5326 U	U 5326 E	U 5326 L	-	-
E 1028 U	L 1028 U	LP 1028 U	U 1028 E	U 1028 L	-	-
E 5028 U	L 5028 U	LP 5028 U	U 5028 E	U 5028 L	-	-
MUC 128	MUL 128	MU 128	MCS 128	ML 128	-	-
MUC 5128	MUL 5128	MU 5128	MCS 5128	ML 5128	-	-
E 1228 U	L 1228 U	LP 1228 U	U 1228 E	U 1228 L	E 1228 B	U 1228 B
E 5228 U	L 5228 U	LP 5228 U	U 5228 E	U 5228 L	E 5228 B	U 5228 B
NU 328 E	NJ 328 E	NUP 328 E	N 328 E	-	-	-
E 1328 U	L 1328 U	LP 1328 U	U 1328 E	U 1328 L	-	-



**ROLLWAY**

**RADIAL ROLLER BEARINGS**

**CYLINDRICAL RADIAL ROLLER BEARINGS**

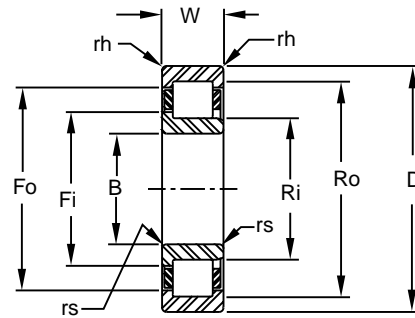

BORE		OUTSIDE DIAMETER		WIDTH		RADIUS		BASIC DYNAMIC CAPACITY	BASIC STATIC CAPACITY	FLANGE O.D. INNER RACE	O.D. INNER RACE	FLANGE I.D. OUTER RACE	I.D. OUTER RACE
B		D		W		rs	rh	POUNDS	POUNDS	Fi	Ri	Fo	Ro
MM	INCH	MM	INCH	MM	INCH	MM				MM			
140	5.5118	300	11.8110	102.0	4.0157	4.0	4.0	208,730	285,920	196.0	180.0	247.2	260.0
	5.5118	300	11.8110	114.3	4.5000	7.9	3.2	254,510	379,890	197.0	181.7	244.3	258.0
150	5.9055	225	8.8583	56.0	2.2047	4.0	2.0	87,140	148,930	176.2	168.7	198.9	206.3
	5.9055	235	9.2520	38.0	1.4961	2.0	2.0	45,500	64,500	182.4	174.6	205.6	212.7
	5.9055	235	9.2520	66.7	2.6250	2.0	2.0	97,020	170,760	182.4	174.6	205.6	212.7
	5.9055	270	10.6299	45.0	1.7717	2.5	2.5	91,030	116,950	191.6	179.4	228.5	239.7
	5.9055	270	10.6299	45.0	1.7717	6.4	2.5	89,920	115,860	193.0	181.5	231.0	241.7
	5.9055	270	10.6299	88.9	3.5000	6.4	2.5	196,160	315,810	193.0	181.5	231.0	241.7
	5.9055	270	10.6299	177.8	7.0000	6.4	2.5	336,310	631,620	193.0	181.5	231.0	241.7
	5.9055	320	12.5984	65.0	2.5591	3.0	3.0	176,570	217,890	192.8	190.0	264.4	280.0
	5.9055	320	12.5984	123.8	4.8750	7.9	3.2	302,480	439,630	208.5	190.9	263.3	279.1
160	6.2992	240	9.4488	38.0	1.4961	4.0	2.0	57,650	88,500	188.8	181.2	212.7	219.3
	6.2992	240	9.4488	60.0	2.3622	4.0	2.0	96,790	172,280	188.8	181.2	212.7	219.3
	6.2992	250	9.8425	40.0	1.5748	2.0	2.0	51,730	73,120	192.3	184.2	218.3	225.4
	6.2992	250	9.8425	73.0	2.8750	2.0	2.0	111,310	195,850	192.3	184.2	218.3	225.4
	6.2992	290	11.4173	48.0	1.8898	2.5	2.5	100,420	130,890	206.0	193.7	245.2	257.2
	6.2992	290	11.4173	48.0	1.8898	6.4	2.5	96,890	125,040	205.9	193.9	243.8	257.4
	6.2992	290	11.4173	98.4	3.8750	6.4	2.5	208,070	334,030	205.9	193.9	243.8	257.4
	6.2992	290	11.4173	196.9	7.7500	6.4	2.5	356,730	668,050	205.9	193.9	243.8	257.4
	6.2992	340	13.3858	68.0	2.6772	9.5	3.2	160,630	198,180	223.5	205.9	278.3	294.1
	6.2992	340	13.3858	68.0	2.6772	3.0	3.0	182,060	222,200	220.5	203.2	283.7	298.5
170	6.6929	260	10.2362	42.0	1.6535	4.7	2.0	77,730	122,150	202.1	194.9	227.1	238.1
	6.6929	260	10.2362	67.0	2.6378	4.7	2.0	123,910	222,460	202.1	194.9	227.1	238.1
	6.6929	265	10.4331	42.0	1.6535	2.5	2.5	66,240	92,720	203.2	193.7	231.8	241.3
	6.6929	265	10.4331	76.2	3.0000	2.5	2.5	132,730	226,590	203.2	193.7	231.8	241.3
	6.6929	310	12.2047	52.0	2.0472	6.4	3.2	115,140	151,540	219.1	205.5	261.5	273.6
	6.6929	310	12.2047	104.8	4.1250	6.4	3.2	236,190	381,670	219.1	205.5	261.5	273.6
	6.6929	360	14.1732	72.0	2.8346	3.0	3.0	182,030	225,300	235.0	219.1	298.5	314.3
	6.6929	360	14.1732	139.7	5.5000	9.5	3.2	369,100	552,190	236.0	216.7	295.7	313.3
	6.6929	360	14.1732	139.7	5.5000	9.5	3.2	369,100	552,190	236.0	216.7	295.7	313.3
180	7.0866	280	11.0236	46.0	1.8110	4.7	2.0	96,180	150,460	215.3	205.6	244.6	254.4
	7.0866	280	11.0236	74.0	2.9134	4.7	2.0	152,040	271,090	215.3	205.6	244.6	254.4
	7.0866	280	11.0236	44.0	1.7323	2.5	2.0	75,240	106,310	214.4	204.8	245.9	255.6
	7.0866	280	11.0236	82.6	3.2500	2.5	2.5	156,010	274,490	214.4	204.8	245.9	255.6
	7.0866	320	12.5984	52.0	2.0472	3.0	3.0	107,920	148,990	235.0	222.3	274.1	285.8
	7.0866	320	12.5984	52.0	2.0472	6.4	3.2	114,690	152,620	229.9	216.3	272.3	284.4
	7.0866	320	12.5984	108.0	4.2500	6.4	3.2	235,260	384,400	229.9	216.3	272.3	284.4
	7.0866	380	14.9606	75.0	2.9528	3.0	3.0	191,500	243,780	250.8	231.8	309.9	327.0
190	7.4803	290	11.4173	46.0	1.8110	4.7	2.5	95,630	151,200	226.9	215.6	26.3	264.4
	7.4803	290	11.4173	75.0	2.9528	4.7	2.5	151,160	272,430	226.9	215.6	26.3	264.4
	7.4803	290	11.4173	85.7	3.3750	2.5	2.5	165,630	299,510	229.2	219.1	259.7	269.9

Notes:

1. Some configurations may not be in production, check for availability
2. Actual retainer options may vary, check for retainer design availability
3. Corners rs & rh are the maximum shaft and housing fillet radius that can be cleared

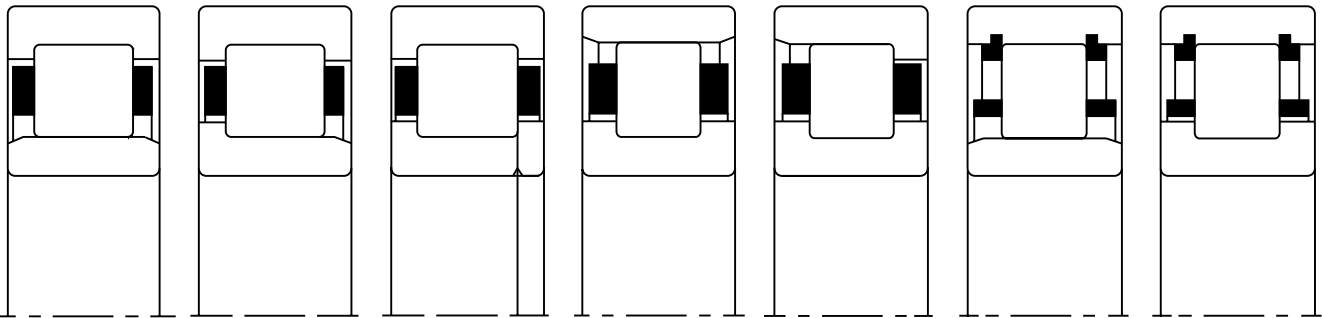

INNER RACE SEPARABLE BOTH DIRECTIONS	INNER RACE SEPARABLE ONE DIRECTION	TWO PIECE INNER RACE FOUR FLANGE DESIGN	OUTER RACE SEPARABLE BOTH DIRECTIONS	OUTER RACE SEPARABLE ONE DIRECTION	INNER RACE SEPARABLE BOTH DIRECTIONS	NONSEPARABLE
NU 2328 E	NJ 2328 E	NUP 2328 E	N 2328 E	-	-	-
E 5328 U	L 5328 U	LP 5328 U	U 5328 E	U 5328 L	-	-
E 5030 U	L 5030 U	LP 5030 U	U 5030 E	U 5030 L	-	-
MUC 130	MUL 130	MU 130	MCS 130	ML 130	-	-
MUC 5130	MUL 5130	MU 5130	MCS 5130	ML 5130	-	-
MUC 230	MUL 230	MU 230	MCS 230	ML 230	-	-
E 1230 U	L 1230 U	LP 1230 U	U 1230 E	U 1230 L	E 1230 B	U 1230 B
E 5230 U	L 5230 U	LP 5230 U	U 5230 E	U 5230 L	E 5230 B	U 5230 B
-	-	-	-	-	E 6230 B	-
MUC 330	MUL 330	MU 330	MCS 330	ML 330	-	-
E 5330 U	L 5330 U	LP 5330 U	U 5330 E	U 5330 L	-	-
E 1032 U	L 1032 U	LP 1032 U	U 1032 E	U 1032 L	-	-
E 5032 U	L 5032 U	LP 5032 U	U 5032 E	U 5032 L	-	-
MUC 132	MUL 132	MU 132	MCS 132	ML 132	-	-
MUC 5132	MUL 5132	MU 5132	MCS 5132	ML 5132	-	-
MUC 232	MUL 232	MU 232	MCS 232	ML 232	-	-
E 1232 U	L 1232 U	LP 1232 U	U 1232 E	U 1232 L	-	-
E 5232 U	L 5232 U	LP 5232 U	U 5232 E	U 5232 L	-	-
-	-	-	-	-	E 6232 B	-
E 1332 U	L 1332 U	LP 1332 U	U 1332 E	U 1332 L	-	-
MUC 332	MUL 332	MU 332	MCS 332	ML 332	-	-
E 1034 U	L 1034 U	LP 1034 U	U 1034 E	U 1034 L	-	-
E 5034 U	L 5034 U	LP 5034 U	U 5034 E	U 5034 L	-	-
MUC 5134	MUL 5134	MU 5134	MCS 5134	ML 5134	-	-
MUC 134	MUL 134	MU 134	MCS 134	ML 134	-	-
E 1234 U	L 1234 U	LP 1234 U	U 1234 E	U 1234 L	-	-
E 5234 U	L 5234 U	LP 5234 U	U 5234 E	U 5234 L	-	-
MUC 334	MUL 334	MU 334	MCS 334	ML 334	-	-
E 5334 U	L 5334 U	LP 5334 U	U 5334 E	U 5334 L	-	-
E 1036 U	L 1036 U	LP 1036 U	U 1036 E	U 1036 L	-	-
E 5036 U	L 5036 U	LP 5036 U	U 5036 E	U 5036 L	-	-
MUC 136	MUL 136	MU 136	MCS 136	ML 136	-	-
MUC 5136	MUL 5136	MU 5136	MCS 5136	ML 5136	-	-
MUC 236	MUL 236	MU 236	MCS 236	ML 236	-	-
E 1236 U	L 1236 U	LP 1236 U	U 1236 E	U 1236 L	-	-
E 5236 U	L 5236 U	LP 5236 U	U 5236 E	U 5236 L	-	-
MUC 336	MUL 336	MU 336	MCS 336	ML 336	-	-
E 1038 U	L 1038 U	LP 1038 U	U 1038 E	U 1038 L	-	-
E 5038 U	L 5038 U	LP 5038 U	U 5038 E	U 5038 L	-	-
MUC 5138	MUL 5138	MU 5138	MCS 5138	ML 5138	-	-





# ROLLWAY®

## RADIAL ROLLER BEARINGS

### CYLINDRICAL RADIAL ROLLER BEARINGS

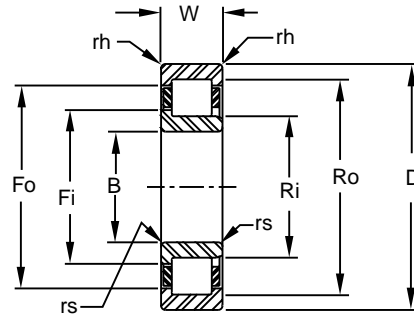

BORE		OUTSIDE DIAMETER		WIDTH		RADIUS		BASIC DYNAMIC CAPACITY	BASIC STATIC CAPACITY	FLANGE O.D. INNER RACE	O.D. INNER RACE	FLANGE I.D. OUTER RACE	I.D. OUTER RACE
B		D		W		rs	rh	POUNDS	POUNDS	Fi	Ri	Fo	Ro
MM	INCH	MM	INCH	MM	INCH	MM	MM			MM	MM	MM	MM
190	7.4803	300	11.8110	46.0	1.8110	2.5	2.5	79,890	117,280	229.2	219.1	259.7	269.9
	7.4803	340	13.3858	114.3	4.5000	7.9	3.2	279,880	471,260	243.3	228.9	288.2	301.0
	7.4803	400	15.7480	78.0	3.0709	4.0	4.0	206,500	260,860	262.9	244.5	303.4	346.1
200	7.8740	310	12.2047	82.0	3.2283	4.7	2.0	174,940	309,140	238.6	227.7	271.6	282.3
	7.8740	320	12.5984	48.0	1.8898	2.5	2.5	96,410	140,260	243.5	231.8	278.9	288.9
	7.8740	320	12.5984	88.9	3.5000	2.5	2.5	189,780	335,060	243.5	231.8	278.9	288.9
	7.8740	360	14.1732	58.0	2.2835	7.9	3.2	139,020	187,210	257.4	242.2	304.9	318.5
	7.8740	360	14.1732	120.7	4.7500	7.9	3.2	300,080	503,470	257.4	242.2	304.9	318.5
	7.8740	420	16.5354	165.1	6.5000	4.0	4.0	471,950	766,680	280.5	260.4	346.1	362.0
210	8.2677	340	13.3858	50.0	1.9685	2.5	2.5	115,120	166,570	257.0	244.5	295.1	308.0
	8.2677	340	13.3858	95.3	3.7500	2.5	2.5	215,040	371,970	257.0	244.5	295.1	308.0
	8.2677	380	14.9606	62.0	2.4409	3.0	3.0	150,000	211,020	276.5	260.4	323.9	336.6
	8.2677	380	14.9606	127.0	5.0000	9.5	3.2	351,140	594,440	270.1	253.6	320.2	336.2
	8.2677	440	17.3228	84.0	3.3071	4.0	4.0	244,640	320,240	287.8	269.9	359.9	377.8
220	8.6614	320	13.3858	90.0	2.9578	6.4	2.5	209,900	390,730	262.8	251.4	297.3	308.6
	8.6614	350	13.7795	98.4	3.8750	2.5	2.5	230,200	411,020	265.4	254.0	307.0	317.5
	8.6614	400	15.7480	65.0	2.5591	3.0	3.0	167,230	232,460	286.5	269.9	336.6	352.4
	8.6614	400	15.7480	65.0	2.5591	9.5	3.2	186,510	253,980	283.2	265.5	342.4	354.4
	8.6614	400	15.7480	133.4	5.2500	9.5	3.2	384,180	643,130	283.2	265.5	342.4	354.4
230	9.0551	370	14.5669	53.0	4.0000	2.5	2.5	134,730	196,180	280.2	266.7	323.9	336.6
	9.0551	370	14.5669	101.6	2.0866	2.5	2.5	244,420	421,910	280.2	266.7	323.9	336.6
	9.0551	420	16.5354	69.0	2.7165	3.0	3.0	185,620	256,200	299.6	282.6	354.5	371.5
240	9.4488	390	15.3543	55.0	2.1654	2.5	2.5	154,990	223,920	291.6	277.8	342.4	354.0
	9.4488	390	15.3543	108.0	4.2500	2.5	2.5	270,030	457,170	291.6	277.8	342.4	354.0
	9.4488	440	17.3228	72.0	2.8346	3.0	3.0	207,890	286,580	309.1	293.7	373.6	388.9
	9.4488	440	17.3228	146.1	5.7500	9.5	3.2	489,340	824,720	311.6	291.2	374.9	393.1
	9.4488	500	19.6850	95.0	3.7402	4.0	4.0	298,100	397,460	328.4	308.0	408.3	428.6
250	9.8425	410	16.1417	57.0	4.3750	3.0	3.0	159,640	236,660	308.7	293.7	354.1	369.9
	9.8425	410	16.1417	111.1	2.2441	3.0	3.0	288,110	505,580	308.7	293.7	354.1	369.9
	9.8425	520	20.4724	196.9	7.7500	4.0	4.0	613,610	1,022,650	354.3	330.2	431.8	450.9
260	10.2362	430	16.9291	59.0	2.3228	3.0	3.0	164,310	249,260	322.8	308.0	372.4	384.2
	10.2362	430	16.9291	114.3	4.5000	3.0	3.0	306,710	556,100	322.8	308.0	372.4	384.2
	10.2362	480	18.8976	158.8	6.2500	4.0	4.0	469,750	802,070	336.7	320.7	406.1	422.3
	10.2362	540	21.2598	102.0	4.0157	5.0	5.0	345,270	477,430	365.3	342.9	445.8	469.9
280	11.0236	460	18.1102	123.8	4.8750	3.0	3.0	354,840	648,750	346.6	330.2	398.8	412.8
	11.0236	500	19.6850	165.1	6.5000	9.5	4.0	635,200	1,111,320	355.6	333.0	427.2	447.3
	11.0236	580	22.8346	215.9	8.5000	12.7	5.0	951,160	1,437,800	368.0	339.9	487.4	517.7

Notes:

1. Some configurations may not be in production, check for availability
2. Actual retainer options may vary, check for retainer design availability
3. Corners rs & rh are the maximum shaft and housing fillet radius that can be cleared

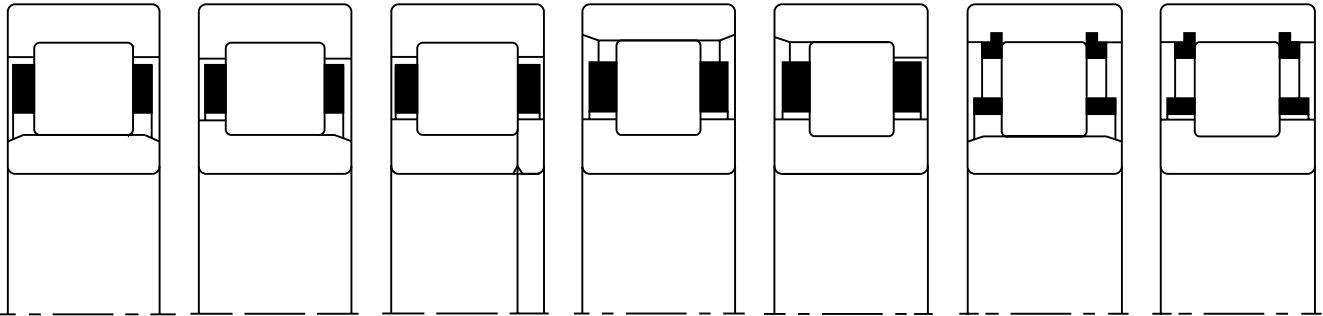

INNER RACE SEPARABLE BOTH DIRECTIONS	INNER RACE SEPARABLE ONE DIRECTION	TWO PIECE INNER RACE FOUR FLANGE DESIGN	OUTER RACE SEPARABLE BOTH DIRECTIONS	OUTER RACE SEPARABLE ONE DIRECTION	INNER RACE SEPARABLE BOTH DIRECTIONS	NONSEPARABLE
MUC 138	MUL 138	MU 138	MCS 138	ML 138	-	-
E 5238 U	L 5238 U	LP 5238 U	U 5238 E	U 5238 L	-	-
MUC 338	MUL 338	MU 338	MCS 338	ML 338	-	-
E 5040 U	L 5040 U	LP 5040 U	U 5040 E	U 5040 L	-	-
MUC 140	MUL 140	MU 140	MCS 140	ML 140	-	-
MUC 5140	MUL 5140	MU 5140	MCS 5140	ML 5140	-	-
E 1240 U	L 1240 U	LP 1240 U	U 1240 E	U 1240 L	-	-
E 5240 U	L 5240 U	LP 5240 U	U 5240 E	U 5240 L	-	-
E 5340 U	L 5340 U	LP 5340 U	U 5340 E	U 5340 L	-	-
MUC 142	MUL 142	MU 142	MCS 142	ML 142	-	-
MUC 5142	MUL 5142	MU 5142	MCS 5142	ML 5142	-	-
MUC 242	MUL 242	MU 242	MCS 242	ML 242	-	-
E 5242 U	L 5242 U	LP 5242 U	U 5242 E	U 5242 L	-	-
MUC 342	MUL 342	MU 342	MCS 342	ML 342	-	-
E 5044 U	L 5044 U	LP 5044 U	U 5044 E	U 5044 L	-	-
MUC 5144	MUL 5144	MU 5144	MCS 5144	ML 5144	-	-
MUC 244	MUL 244	MU 244	MCS 244	ML 244	-	-
E 1244 U	L 1244 U	LP 1244 U	U 1244 E	U 1244 L	-	-
E 5244 U	L 5244 U	LP 5244 U	U 5244 E	U 5244 L	-	-
MUC 146	MUL 146	MU 146	MCS 146	ML 146	-	-
MUC 5146	MUL 5146	MU 5146	MCS 5146	ML 5146	-	-
MUC 246	MUL 246	MU 246	MCS 246	ML 246	-	-
MUC 148	MUL 148	MU 148	MCS 148	ML 148	-	-
MUC 5148	MUL 5148	MU 5148	MCS 5148	ML 5148	-	-
MUC 248	MUL 248	MU 248	MCS 248	ML 248	-	-
E 5248 U	L 5248 U	LP 5248 U	U 5248 E	U 5248 L	-	-
MUC 348	MUL 348	MU 348	MCS 348	ML 348	-	-
MUC 150	MUL 150	MU 150	MCS 150	ML 150	-	-
MUC 5150	MUL 5150	MU 5150	MCS 5150	ML 5150	-	-
E 5350 U	L 5350 U	LP 5350 U	U 5350 E	U 5350 L	-	-
MUC 152	MUL 152	MU 152	MCS 152	ML 152	-	-
MUC 5152	MUL 5152	MU 5152	MCS 5152	ML 5152	-	-
E 5252 U	L 5252 U	LP 5252 U	U 5252 E	U 5252 L	-	-
MUC 352	MUL 352	MU 352	MCS 352	ML 352	-	-
MUC 5156	MUL 5156	MU 5156	MCS 5156	ML 5156	-	-
E 5256 U	L 5256 U	LP 5256 U	U 5256 E	U 5256 L	-	-
E 5356 U	L 5356 U	LP 5356 U	U 5356 E	U 5356 L	-	-

## CYLINDRICAL RADIAL ROLLER BEARINGS

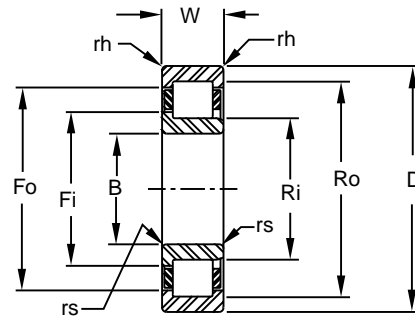

BORE		OUTSIDE DIAMETER		WIDTH		RADIUS		BASIC DYNAMIC CAPACITY	BASIC STATIC CAPACITY	FLANGE O.D. INNER RACE	O.D. INNER RACE	FLANGE I.D. OUTER RACE	I.D. OUTER RACE
B		D		W		rs	rh	POUNDS	POUNDS	Fi	Ri	Fo	Ro
MM	INCH	MM	INCH	MM	INCH	MM				MM			
300	11.8110	480	18.8970	127.0	5.0000	8.0	3.2	383,930	690,680	360.7	344.5	419.0	433.4
	11.8110	540	21.2590	85.0	3.3465	12.7	4.0	381,750	486,330	366.6	343.8	470.3	496.2
320	12.5984	500	19.6850	71.0	2.7953	3.0	3.0	219,370	341,900	381.3	363.5	437.1	452.4
	12.5984	500	19.6850	130.2	5.1250	4.0	3.0	394,850	727,920	381.3	363.5	437.1	452.4
340	13.3850	530	20.8661	133.4	5.2500	-	-	324,290	645,580	415.4	399.3	462.6	475.5
425	16.7480	610	24.0157	146.1	5.7500	-	-	465,750	916,530	469.9	453.7	532.8	549.0
440	17.3228	660	25.9843	158.8	6.2500	-	-	486,790	1,002,350	520.8	503.7	582.8	599.0

Notes:

1. Some configurations may not be in production, check for availability
2. Actual retainer options may vary, check for retainer design availability
3. Corners rs & rh are the maximum shaft and housing fillet radius that can be cleared



**ROLLWAY®**

**RADIAL ROLLER BEARINGS**

**CYLINDRICAL RADIAL ROLLER BEARINGS**

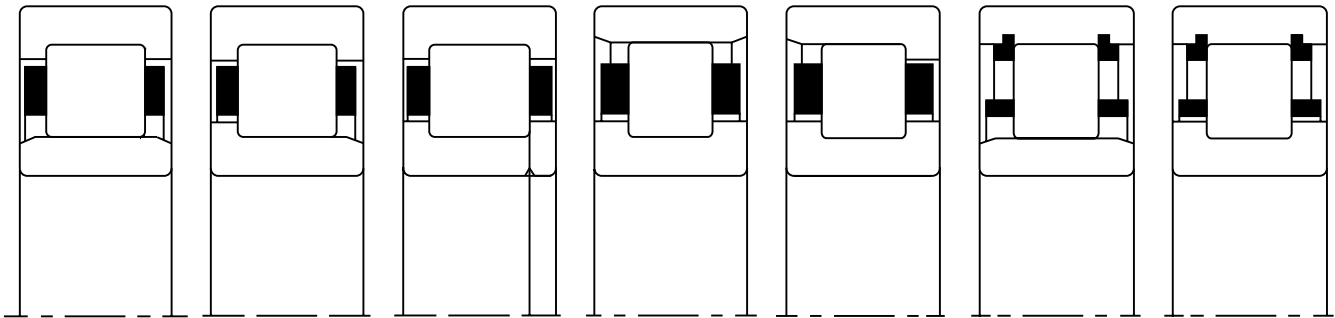

INNER RACE SEPARABLE BOTH DIRECTIONS	INNER RACE SEPARABLE ONE DIRECTION	TWO PIECE INNER RACE FOUR FLANGE DESIGN	OUTER RACE SEPARABLE BOTH DIRECTIONS	OUTER RACE SEPARABLE ONE DIRECTION	INNER RACE SEPARABLE BOTH DIRECTIONS	NONSEPARABLE
MUC 5160	MUL 5160	MU 5160	MCS 5160	ML 5160	-	-
E 1260 U	L 1260 U	LP 1260 U	U 1260 E	U 1260 L	-	-
MUC 164	MUL 164	MU 164	MCS 164	ML 164	-	-
MUC 5164	MUL 5164	MU 5164	MCS 5164	ML 5164	-	-
MUC 5168	MUL 5168	MU 5168	MCS 5168	ML 5168	-	-
MUC 5180	MUL 5180	MU 5180	MCS 5180	ML 5180	-	-
MUC 5188	MUL 5188	MU 5188	MCS 5188	ML 5188	-	-



**ROLLWAY**

**RADIAL ROLLER BEARINGS**

**CYLINDRICAL RADIAL ROLLER BEARINGS APPLICATIONS**

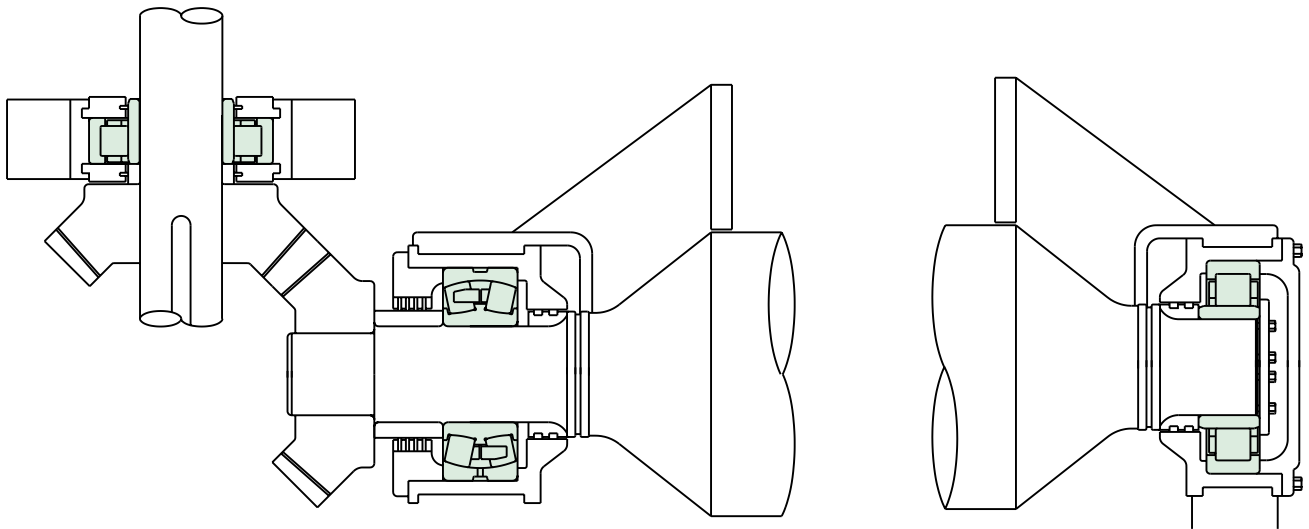

***Rolling Mill Runout Table Applications  
Line Shaft and Table Roll Support***

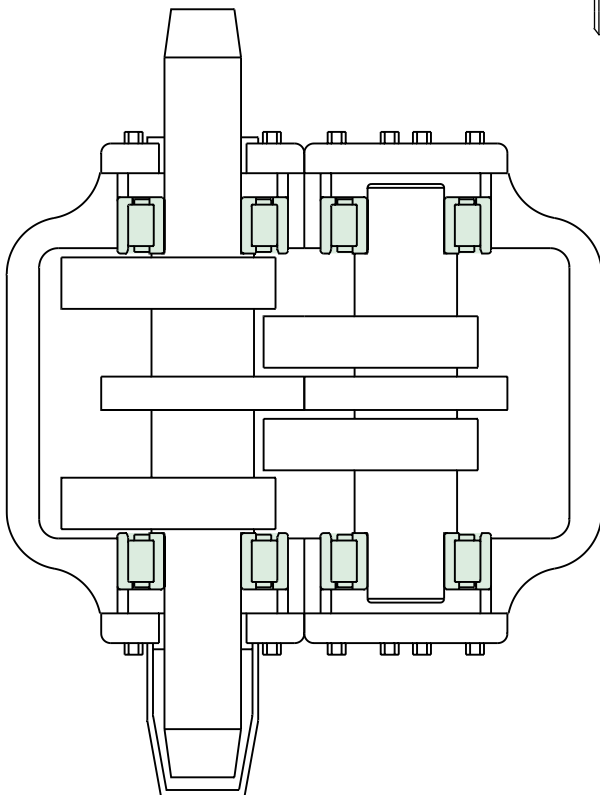

***Shaker Screen  
Exciter Mechanism***

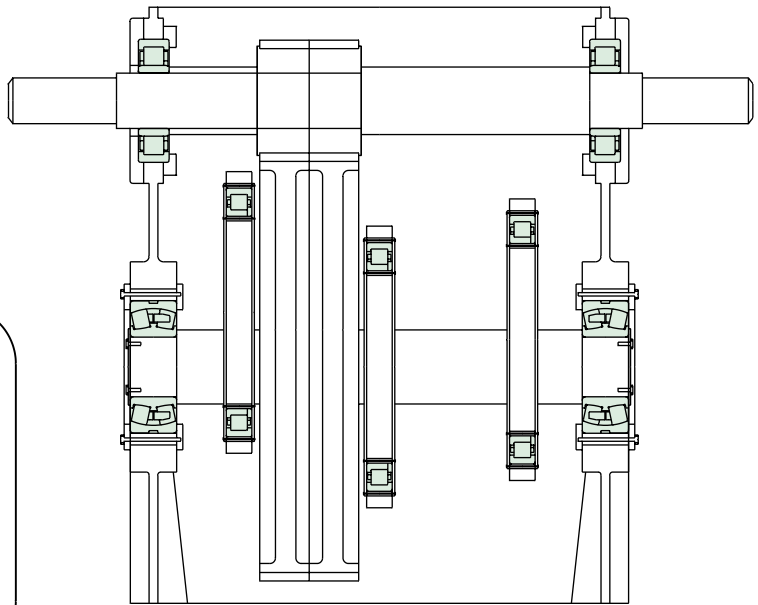

***Oilfield Mud Pump***





**ROLLWAY**

**RADIAL ROLLER BEARINGS**

**CYLINDRICAL RADIAL ROLLER BEARINGS APPLICATIONS**

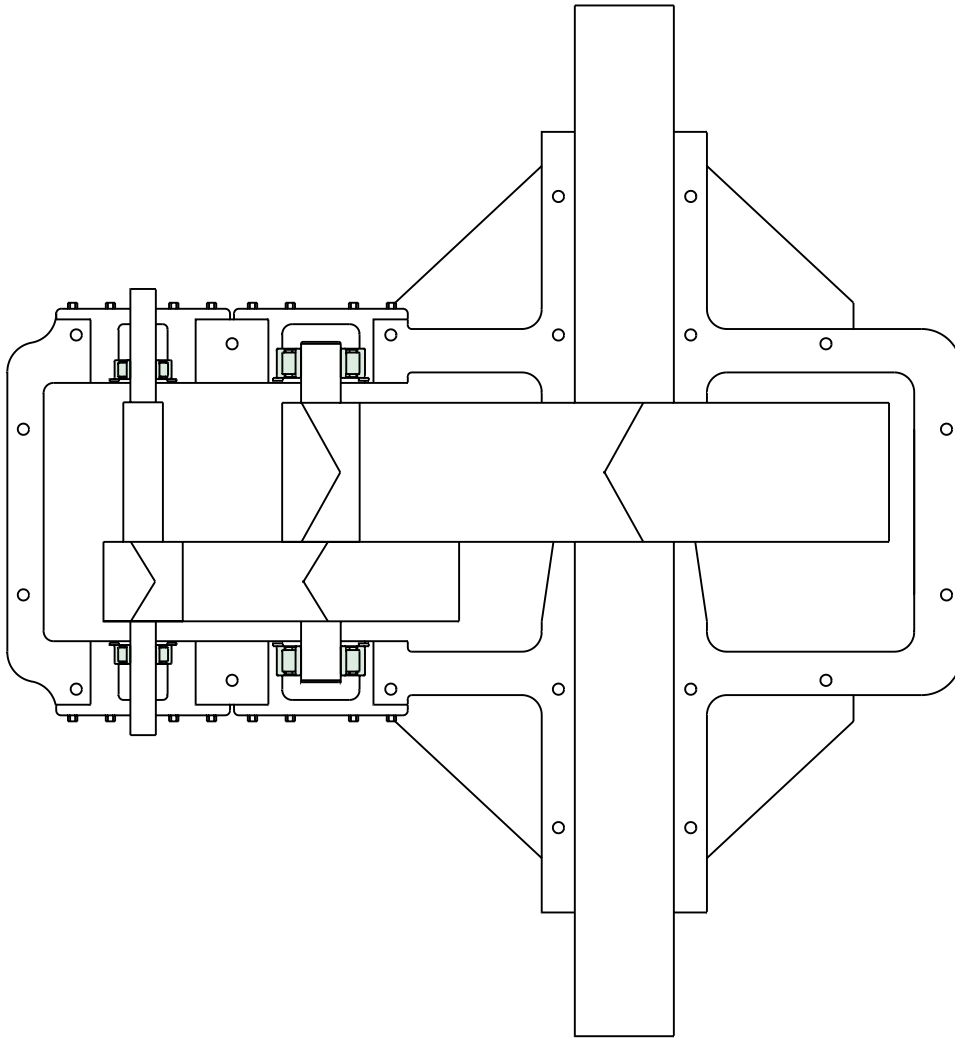

***Pump Jack Gear Drive***

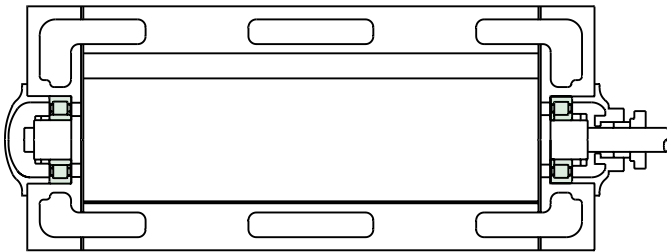

***Rotary Vane Compressor***

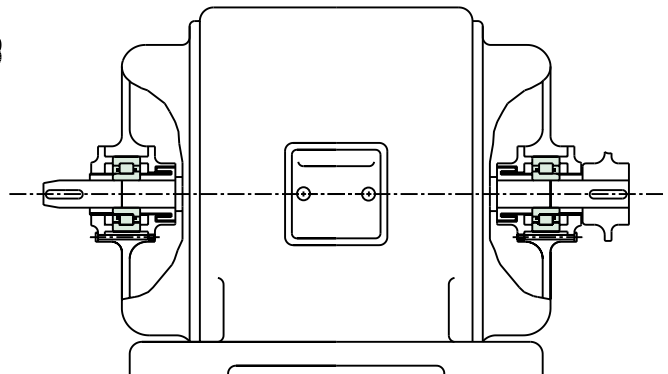

***DC Electric Motor***



## *Thrust Bearings...*

*The ROLLWAY offering is one of the most complete lines of standard and engineered roller thrust bearings. Our standard catalog contains inch series cylindrical roller, tapered and multi-stage tandem thrust bearings. We understand the uniqueness of thrust bearing applications and have designed hundreds of custom bearings to solve the most challenging applications.*



# ***Designed and Built to Solve Thrust Application Problems...***

- Roller thrust bearings for high speed applications.
- Thrust bearings for high temperature applications.
- Engineered sizes up to 42" outside diameter.
- Designs requiring anti-rotation features on the plates.
- Designs requiring lifting holes.
- Thrust bearings with integral radial roller bearings.

*The following section details the design features of our standard product offering.*

***Keep in mind...***

***A Custom Engineered Solution Is Just A Phone Call Away.***



***Inch Series  
Cylindrical Thrust***



***Tapered Thrust***

***Multi-Stage Tandem Thrust***





# Cylindrical Roller Thrust

## Inch Series

The ROLLWAY inch series thrust bearings are a simply constructed thrust bearing of high capacity. These bearings are designed to support thrust loads (load parallel to the axis of rotation) at relatively high speeds. There are three basic styles of inch series thrust bearings:

- **Single Acting** - supports thrust load in one direction.
- **Aligning** - accepts an initial static misalignment of no more than 3°.
- **Double Acting** - supports thrust loads in both directions.



### Shaft Plate

Bore is precision ground for a line to loose fit on shaft. The O.D. has a turned finish and is smaller than the housing plate's O.D.

### Roller Assembly

Machined brass roller riding cage. Rollers are matched to .0001".

### Housing Plate

O.D. is precision ground for a line to loose fit in housing bore. The I.D. has a turned finish and is larger than the shaft plate's I.D.

**All three types are made from the same basic components.**

## Basic Bearing Design... Thrust Bearing Components

### Plates and Rolling Elements...

The plates and rollers are made from either through-hardened or carburizing grade steel with hardness to Rockwell (Rc) 58-63. Upon request we can manufacture these components from CEVM or VIMVAR grades of material and M-50 tool steel for high temperature applications.

All thrust plates are accurately ground for flatness and parallelism of the roller riding and backing surfaces. The contact surfaces of the plates are superfinished to provide for long life. Locating diameters are ground to obtain an accurate fit on the shaft or in the housing.

All rolling elements are precision ground to provide even distribution of load over the contact surfaces. The rollers are all crowned thus permitting unmodified use of the ABMA's capacity formula. Roller crowning reduces the edge stresses between the roller and the thrust plates.

### Roller and Retainer Assemblies...

ROLLWAY Thrust bearing retainers are machined from centrifugally cast brass. The retainers for all cylindrical roller thrust bearings are designed to be roller riding. The contoured roller pockets are accurately machined at right angles to the thrust force which will be applied to the bearing. The rollers are retained in the assembly by a steel ring pinned to the outside diameter of the retainer. It should be noted that the ROLLWAY design has a sphered roller end which rides against the steel retaining ring for reduced wear (the center of the contact point has zero velocity vs the higher velocity that results from a flat ended roller contacting the ring).

## Bearing Classes...

Cylindrical roller thrust bearings are divided into *two basic classes: medium (600 series) and heavy (700 series)*. The medium series has a smaller cross section and the retainer typically has only one roller per roller pocket. The heavy series has a larger cross section and the retainer typically has more than one roller per roller pocket.

## Thrust Bearing Types and Styles...

### Inch Series — Single Acting

The single acting bearing is the most popular thrust bearing of the inch series. The bearing is often referred to as a “three piece thrust bearing”. One of the thrust plates is stationary with respect to the shaft and is ground in the bore for an accurate fit on the shaft. The roller assembly is located by the shaft and its inside diameter is machined to provide the correct operating clearance. The second thrust plate is stationary with the housing and is ground on the outside diameter for an accurate fit in the housing. The non-locating diameters of both thrust plates are specially designed to allow lubricant flow.



The sizes range from 1 to 22 inches I.D. and 2.125 to 34 inches O.D. with dynamic capacities from 10,000 lbs. to 1,620,000 lbs. These bearings are used in a variety of applications such as extruder gear drives, pumps, crane hook swivels and machine tools.

### Design Variations Of The Inch Series Thrust Bearing...

There are standard design variations of the inch series thrust bearing. Each design is based on a standard single acting inch series thrust bearing and has special added components to modify its function.

#### “AT” Aligning Type

The aligning style design replaces the housing plate with aligning plates. The aligning plates are matched plates, one convex and one concave, that all will correct for 3° initial static misalignment. These aligning plates are not designed for applications requiring dynamic aligning capabilities. They are designed to correct an initial misalignment prior to full loading. The concave plate (housing plate) is precision ground but not hardened.

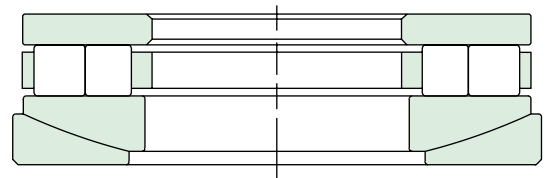

The standard “AT” type is recommended for vertical shaft applications. Where the alignment feature is required in some horizontal shaft applications, the convex aligning plate may ride on the shaft and the plate should be modified to provide a satisfactory bearing surface in the bore. This is usually achieved by the installation of a brass bushing into the bore of the plate.

## *Thrust Bearing Types and Styles...*

### **Crane Hook Thrust Bearings**

Crane Hook Bearings are similar to the single acting inch series but are specifically designed for crane hooks or similar applications where heavy thrust loads and low speeds of rotation are encountered. Crane Hook Bearings are simply single acting thrust bearing supplied with a weathershed. The weathershed is a steel band pressed on to the rotating plate extending to the middle of the stationary plate forming a shield to protect the roller assembly. The weathersheds are supplied with or without grease fittings.



This type of bearing undergoes static loading in normal applications. Our static capacities are based on a total permanent deformation of .0002 inch per inch of roller diameter and is not the ABMA basic capacity.

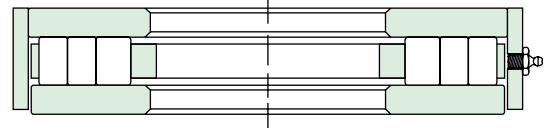

### **“DT” Double Acting Thrust**

The “DT” type thrust bearing is a double acting thrust bearing which will withstand reversal in the direction of the load at normal speeds of rotation. The center thrust plate and sleeve must be keyed to the shaft or clamped tightly between the shaft shoulders to prevent rotation of the center plate relative to the shaft. The two outer thrust plates are stationary with respect to the housing. There are two roller assemblies on either side of the center thrust plate. The center plate drives the roller assembly corresponding to the direction of the thrust load.

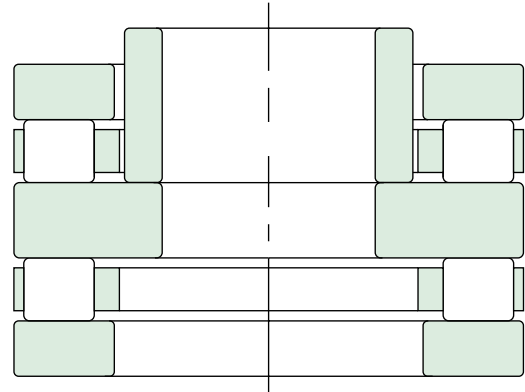

### **“DAT” Aligning, Double Acting Thrust**

This bearing is basically a combination of the “DT” type and the “AT” type. The bearing is designed to take reversals in thrust load and correct for initial static misalignment up to 3°.

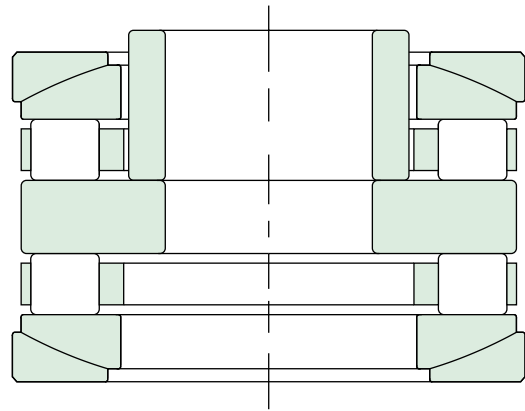

### **“SDT” Simplified Double Acting Thrust**

This bearing is similar in concept to the “DT” double acting type except the design has been simplified to only one roller assembly and two thrust plates. With the load in one direction, one of the thrust plates is stationary with respect to the housing and the other thrust plate rotates. When the direction of the load is reversed, the stationary plate rotates and the rotating plate becomes the stationary plate. To provide necessary clearance for this action, the inner and outer spacer sleeves are made wider than the combined thickness of the thrust plates and roller assembly. This bearing is recommended for applications where the direction of the thrust load changes when the bearing is stationary or rotating at slow speed.

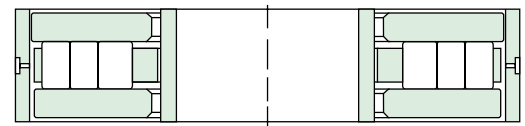



### Nomenclature

The basic numbering system for the thrust bearings is broken into 3 parts; **Bearing type designator**, **Size designator** and **Variation code**.

Example:

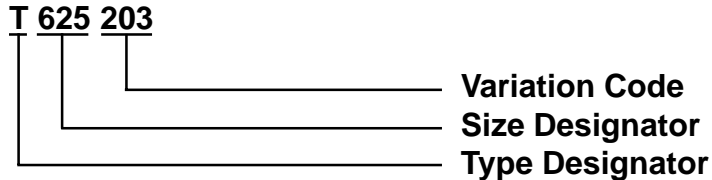

### TYPE DESIGNATOR - *Bearing configuration description*

**T** ..... Single acting thrust.

**AT** ..... Single acting thrust - aligning type.

**DT** ..... Double acting thrust.

**DAT** ..... Double acting thrust - aligning type.

**SDT** ..... Double acting thrust - simplified design.

**CT** ..... Single acting thrust - special design for crane hook applications with weathershed.

**WCT** ..... Single acting thrust - special design for crane hook applications with weathershed and grease fitting.

### SIZE DESIGNATOR

Reference catalog for sizes.

**VARIATION CODES** - Variation codes are divided into two categories: **Special** and **Standard**.

#### Special variation codes...

**201 to 215 & 240 to 254** are numerically assigned codes that designate the variation from standard (example 201 = 1st variation, 202 = 2nd variation, etc.). These bearing code numbers do not in any way reference the modification from standard. Engineering must be contacted for information concerning a particular modification.

#### Standard variation codes...

**216 to 239 & 255 to 299** are code numbers representing standard modifications with the most popular listed below:

- **059** - Brass retainer - this code is obsolete, all standard thrust bearings are supplied with centrifugally cast brass retainers.
- **210** - Roller assembly supplied with hardened steel outer ring.
- **216** - Standard bearing supplied without shaft plate.
- **219** - Tandem bearing design (typically these have been replaced with TAB to TAC bearings).
- **221** - Standard bearing with a brass ring pressed in bore for horizontal shaft applications.
- **226** - Standard bearing supplied with two shaft plates.
- **229** - Same as 219.

### Cylindrical Roller Thrust 600 Series...

- Medium Series Cylindrical Roller Thrust.
- Standard Inch Series.
- Machined Brass Retainers - Standard.
- Crowned Rollers with Sphered Ends.

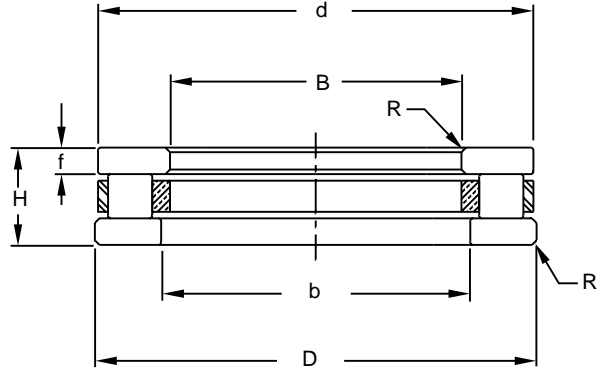

Basic Bearing Number	Bore B	Outside Diameter D	Height H	Internal Dimensions			Housing & Shaft Fillet R	Est. Weight	Capacity		Limiting Speed	
				b	d	f			dynamic C	static Co	grease	oil
				Inches					Pounds		RPM	
T601	1.000	2.125	0.812	1.130	2.000	0.220	0.031	0.5	10,550	18,760	3,440	6,880
T602	1.062	2.125	0.812	1.130	2.000	0.220	0.031	0.5	10,550	18,760	3,370	6,750
T603	1.125	2.250	0.812	1.250	2.150	0.220	0.031	0.6	12,140	25,540	3,190	6,370
T604	1.187	2.250	0.812	1.250	2.150	0.220	0.031	0.6	12,140	25,540	3,130	6,260
T605	1.250	2.375	0.812	1.430	2.310	0.220	0.031	0.6	13,280	28,380	2,970	5,930
T606	1.312	2.375	0.812	1.430	2.310	0.220	0.031	0.6	13,280	28,380	2,920	5,830
T607	1.375	2.875	0.812	1.630	2.790	0.220	0.031	1	17,470	47,800	2,530	5,060
T608	1.437	2.875	0.812	1.630	2.790	0.220	0.031	1	17,470	47,800	2,490	4,990
T609	1.500	3.000	0.812	1.750	2.900	0.220	0.031	1	18,730	52,140	2,390	4,780
T610	1.562	3.000	0.812	1.750	2.900	0.220	0.031	1	18,730	52,140	2,360	4,710
T611	1.625	3.250	1.000	1.880	3.150	0.250	0.062	1.5	25,620	67,380	2,210	4,410
T612	1.687	3.250	1.000	1.880	3.150	0.250	0.062	1.5	25,620	67,380	2,180	4,350
T613	1.750	3.375	1.000	2.030	3.300	0.250	0.062	1.6	27,670	74,120	2,100	4,200
T614	1.812	3.375	1.000	2.030	3.300	0.250	0.062	1.6	27,670	74,120	2,070	4,140
T615	1.875	3.500	1.000	2.130	3.410	0.250	0.062	1.7	27,760	74,120	2,000	4,000
T616	1.937	3.500	1.000	2.130	3.410	0.250	0.062	1.6	27,760	74,120	1,980	3,950
T617	2.000	3.625	1.000	2.190	3.500	0.250	0.062	1.7	27,870	74,120	1,910	3,820
T618	2.125	3.750	1.000	2.380	3.650	0.250	0.062	1.8	28,740	80,850	1,830	3,660
T619	2.250	3.875	1.000	2.440	3.750	0.250	0.062	1.9	32,030	87,590	1,760	3,510
T620	2.375	4.000	1.000	2.630	3.900	0.250	0.062	2	32,250	87,590	1,690	3,370
T621	2.500	4.125	1.000	2.670	4.000	0.250	0.062	2.1	34,180	94,330	1,620	3,250
T622	2.625	4.343	1.000	2.880	4.220	0.250	0.062	2.3	36,150	101,070	1,540	3,090
T623	2.750	4.468	1.000	3.060	4.340	0.250	0.062	2.4	38,350	107,800	1,490	2,980
T624	3.000	4.718	1.000	3.250	4.590	0.250	0.062	2.6	40,510	114,540	1,390	2,790
T625	3.250	4.968	1.000	3.500	4.840	0.250	0.062	2.7	40,770	114,540	1,310	2,620
T626	3.500	5.218	1.000	3.750	5.090	0.250	0.062	2.9	44,350	128,020	1,230	2,470

### Cylindrical Roller Thrust 600 Series With Aligning Plates...

- Medium Series Cylindrical Roller Thrust.
- Standard Inch Series.
- Allows for 3° Initial Static Misalignment.
- Machined Brass Retainers - Standard.
- Crowned Rollers with Sphered Ends.

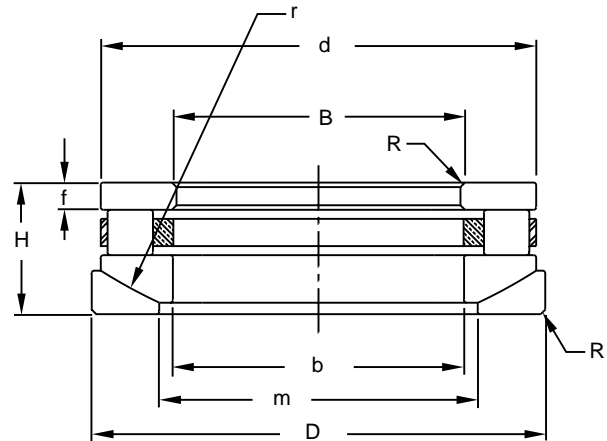

Basic Bearing Number	Bore B	Outside Diameter D	Height H	Internal Dimensions					Housing & Shaft Fillet R	Est. Weight	Capacity		Limiting Speed	
				b	d	f	m	f			dynamic C	static Co	grease	oil
				Inches							Pounds		RPM	
AT601	1.000	2.250	1.062	1.130	2.000	0.220	1.31	1.500	0.031	0.7	10,550	18,760	3,440	6,880
AT602	1.062	2.250	1.062	1.130	2.000	0.220	1.31	1.500	0.031	0.7	10,550	18,760	3,370	6,750
AT603	1.125	2.375	1.062	1.250	2.150	0.220	1.44	1.750	0.031	0.8	12,140	25,540	3,190	3,370
AT604	1.187	2.375	1.062	1.250	2.150	0.220	1.44	1.750	0.031	0.7	12,140	25,540	3,130	6,260
AT605	1.250	2.500	1.062	1.380	2.310	0.220	1.50	1.875	0.031	0.8	13,280	28,380	2,970	5,930
AT606	1.312	2.500	1.062	1.380	2.310	0.220	1.63	1.875	0.031	0.8	13,280	28,380	2,920	5,830
AT607	1.375	3.000	1.062	1.500	2.790	0.220	1.81	2.750	0.031	1.3	17,470	47,800	2,530	5,060
AT608	1.437	3.000	1.062	1.500	2.790	0.220	1.81	2.750	0.031	1.3	17,470	47,800	2,490	4,990
AT609	1.500	3.125	1.062	1.630	2.900	0.220	1.88	3.000	0.031	1.4	18,730	52,140	2,390	4,780
AT610	1.562	3.125	1.062	1.630	2.900	0.220	1.88	3.000	0.031	1.4	18,730	52,140	2,360	4,710
AT611	1.625	3.375	1.312	1.750	3.150	0.250	2.00	3.000	0.031	2	25,620	67,380	2,210	4,410
AT612	1.687	3.375	1.312	1.750	3.150	0.250	2.00	3.000	0.062	2	25,620	67,380	2,180	4,350
AT613	1.750	3.500	1.312	1.880	3.300	0.250	2.06	3.250	0.062	2	27,670	74,120	2,100	4,200
AT614	1.812	3.500	1.312	1.880	3.300	0.250	2.06	3.250	0.062	2	27,670	74,120	2,070	4,140
AT615	1.875	3.625	1.312	2.000	3.410	0.250	2.25	3.250	0.062	2.2	27,760	74,120	2,000	4,000
AT616	1.937	3.625	1.312	2.000	3.410	0.250	2.25	3.250	0.062	2.2	27,760	74,120	1,980	3,950
AT617	2.000	3.750	1.312	2.060	3.520	0.250	2.48	3.250	0.062	2.3	27,870	74,120	1,910	3,820
AT618	2.125	3.875	1.312	2.190	3.650	0.250	2.50	3.500	0.062	2.3	28,740	80,850	1,830	3,660
AT619	2.250	4.000	1.312	2.310	3.750	0.250	2.69	3.500	0.062	2.5	32,030	87,590	1,760	3,510
AT620	2.375	4.125	1.312	2.440	3.900	0.250	2.88	3.500	0.062	2.6	32,250	87,590	1,690	3,370
AT621	2.500	4.250	1.312	2.560	4.000	0.250	2.88	4.000	0.062	2.7	34,180	94,330	1,620	3,250
AT622	2.625	4.530	1.312	2.690	4.220	0.250	3.13	3.750	0.062	3	36,150	101,070	1,540	3,090
AT623	2.750	4.655	1.312	2.810	4.340	0.250	3.31	4.250	0.062	3.2	38,350	107,800	1,490	2,980
AT624	3.000	4.968	1.312	3.060	4.590	0.250	3.50	4.500	0.062	3.4	40,510	114,540	1,390	2,790
AT625	3.250	5.218	1.312	3.340	4.840	0.250	3.81	4.750	0.062	3.6	40,770	114,540	1,310	2,620
AT626	3.500	5.468	1.312	3.590	5.090	0.250	4.06	5.000	0.062	3.8	44,350	128,020	1,230	2,470



# ROLLWAY®

## THRUST BEARINGS

### Cylindrical Roller Thrust 700 Series...

- Heavy Series Cylindrical Roller Thrust.
- Standard Inch Series.
- Machined Brass Retainers - Standard.
- Crowned Rollers with Sphered Ends.

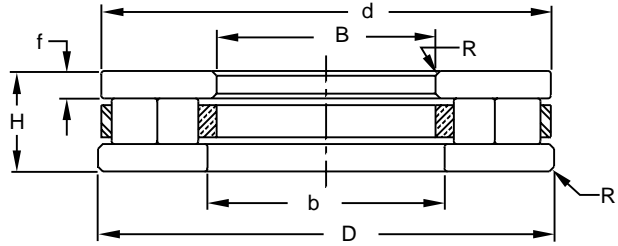

Basic Bearing Number	Bore B	Outside Diameter D	Height H	Internal Dimensions			Housing & Shaft Fillet R	Est. Weight	Capacity		Limiting Speed	
				b	d	f			dynamic C	static Co	grease	oil
				Inches					Inches			
T727	2.000	6.000	1.375	2.250	5.880	0.380	0.062	8.6	77,500	295,900	1,340	2,690
T728	2.000	7.000	1.375	2.250	6.880	0.380	0.062	11.7	105,600	363,600	1,190	2,390
T729	2.000	8.000	1.375	2.250	7.880	0.380	0.062	16	111,900	460,200	1,080	2,150
T730	3.000	6.000	1.375	3.250	5.880	0.380	0.062	7.3	82,200	268,000	1,190	2,390
T731	3.000	7.000	1.375	3.250	6.880	0.380	0.062	10.8	98,800	365,800	1,080	2,150
T732	3.000	8.000	1.375	3.250	7.880	0.380	0.062	14.7	126,200	494,500	980	1,950
T733	3.000	9.000	1.375	3.250	8.880	0.380	0.062	19.2	147,500	642,800	900	1,790
T734	4.000	7.000	1.750	4.250	6.880	0.500	0.062	11.4	111,100	320,500	980	1,950
T735	4.000	8.000	1.750	4.250	7.880	0.500	0.062	16.6	132,200	454,200	900	1,790
T736	4.000	9.000	1.750	4.250	8.880	0.500	0.062	22.4	158,400	658,100	830	1,650
T737	4.000	10.000	1.750	4.250	9.880	0.500	0.062	29	192,200	777,800	770	1,540
T738	5.000	8.000	1.750	5.250	7.880	0.500	0.062	13.5	111,000	419,400	830	1,650
T739	5.000	9.000	1.750	5.250	8.880	0.500	0.062	19.5	162,000	631,800	770	1,540
T740	5.000	10.000	2.000	5.250	9.880	0.560	0.125	30	205,100	703,300	720	1,430
T741	5.000	11.000	2.000	5.250	10.880	0.560	0.125	38	231,200	870,900	670	1,340
T742	5.000	12.000	2.000	5.250	11.880	0.560	0.125	47	276,100	1,144,000	630	1,260
T743	6.000	9.000	2.000	6.380	8.750	0.560	0.125	18	130,600	450,100	720	1,430
T744	6.000	10.000	2.000	6.380	9.750	0.560	0.125	25	190,300	648,600	670	1,340
T745	6.000	11.000	2.000	6.380	10.750	0.560	0.125	34	233,400	929,900	630	1,260
T746	6.000	12.000	2.000	6.380	11.750	0.560	0.125	42	267,000	1,097,100	600	1,190
T747	7.000	10.000	2.000	7.380	9.750	0.560	0.125	20	154,500	550,100	630	1,260
T748	7.000	11.000	2.000	7.380	10.750	0.560	0.125	28	213,600	790,800	600	1,190
T749	7.000	12.000	2.000	7.380	11.750	0.560	0.125	40	251,600	1,022,900	570	1,130
T750	7.000	14.000	3.000	7.380	13.750	0.880	0.250	88	436,200	1,598,200	510	1,020
T751	8.000	12.000	3.000	8.380	11.750	0.880	0.250	48	258,000	945,400	540	1,080
T752	8.000	14.000	3.000	8.380	13.750	0.880	0.250	78	397,500	1,487,900	490	980
T753	8.000	16.000	3.000	8.380	15.750	0.880	0.250	114	516,400	2,072,500	450	900
T754	10.000	16.000	3.000	10.380	15.750	0.880	0.250	88	437,800	1,747,200	410	830
T755	10.000	18.000	3.750	10.380	17.750	1.130	0.250	168	614,200	2,697,600	380	770
T756	10.000	20.000	3.750	10.380	19.750	1.130	0.250	225	766,000	3,250,900	360	720
T757	12.000	18.000	3.750	12.500	17.750	1.130	0.250	134	469,200	2,031,900	360	720
T758	12.000	20.000	4.500	12.500	19.750	1.380	0.250	222	724,600	2,937,800	340	670
T759	12.000	24.000	4.500	12.500	23.750	1.380	0.250	372	1,045,900	4,688,000	300	600
T760	14.000	20.000	3.750	14.500	19.750	1.130	0.250	152	540,000	2,385,200	320	630
T761	14.000	22.000	3.750	14.500	21.750	1.130	0.250	215	732,000	3,339,900	300	600
T762	14.000	24.000	3.750	14.500	23.750	1.130	0.250	285	858,100	4,280,300	280	570
T763	16.000	22.000	4.500	16.500	21.500	1.380	0.250	205	609,800	2,362,800	280	570
T764	16.000	24.000	4.500	16.500	23.500	1.380	0.250	290	878,700	3,819,100	270	540
T765	16.000	26.000	4.500	16.500	25.500	1.380	0.250	380	1,041,500	4,916,300	260	510
T766	18.000	26.000	5.000	18.750	25.500	1.500	0.250	350	945,500	3,937,500	240	490
T767	18.000	28.000	5.000	18.750	27.500	1.500	0.250	460	1,185,800	5,393,500	230	470
T768	18.000	30.000	5.500	18.750	29.500	1.500	0.250	630	1,571,600	6,753,800	220	450
T769	20.000	28.000	5.500	21.250	27.500	1.500	0.250	420	1,091,700	4,407,200	220	450
T770	20.000	30.000	5.500	21.250	29.500	1.500	0.250	550	1,544,800	6,885,500	220	430
T771	20.000	32.000	6.000	21.250	31.500	1.750	0.250	750	#N/A	7,850,000	210	410
T772	22.000	30.000	5.500	23.250	29.500	1.500	0.250	450	1,161,900	4,774,500	210	410
T773	22.000	32.000	5.500	23.250	31.500	1.500	0.250	590	#N/A	6,153,200	200	400
T774	22.000	34.000	6.000	23.250	33.500	1.750	0.250	800	1,742,200	7,981,700	190	380

## Cylindrical Roller Thrust 700 Series With Aligning Plates...

- Medium Series Cylindrical Roller Thrust.
- Standard Inch Series.
- Allows for 3° Initial Static Misalignment.
- Machined Brass Retainers - Standard.
- Crowned Rollers with Sphered Ends.

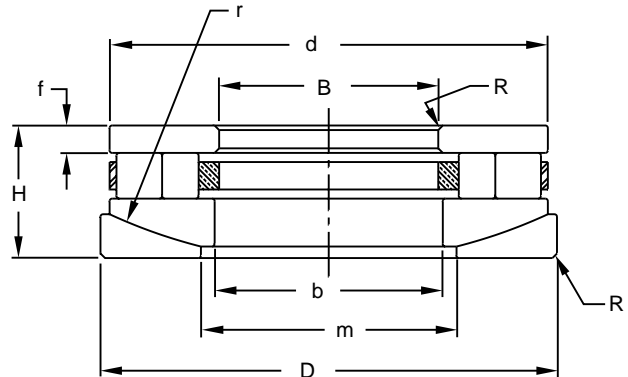

Basic Bearing Number	Bore B	Outside Diameter D	Height H	Internal Dimensions					Housing & Shaft Fillet R	Est. Weight	Capacity		Limiting Speed	
				b	d	f	m	f			dynamic C	static Co	grease	oil
				Inches							Pounds		RPM	
AT727	2.000	6.312	1.812	2.060	5.880	0.380	3.38	7.500	0.062	11.5	78,190	294,150	1,340	2,690
AT728	2.000	7.312	1.812	2.060	6.880	0.380	4.25	9.500	0.062	15.8	102,870	360,770	1,190	2,390
AT729	2.000	8.312	1.812	2.060	7.880	0.380	5.00	12.000	0.062	21.5	114,430	481,330	1,080	2,150
AT730	3.000	6.312	1.812	3.060	5.880	0.380	4.00	6.000	0.062	9.6	80,300	80,300	1,190	2,390
AT731	3.000	7.312	1.812	3.060	6.880	0.380	4.38	9.500	0.062	14.3	98,800	96,890	1,080	2,150
AT732	3.000	8.312	1.812	3.060	7.880	0.380	5.25	12.000	0.062	20	123,740	123,740	980	1,950
AT733	3.000	9.312	1.812	3.060	8.880	0.380	6.25	14.000	0.062	26	97,630	97,630	900	1,790
AT734	4.000	7.375	2.312	4.090	6.880	0.500	5.00	6.375	0.062	15	159,510	159,510	980	1,950
AT735	4.000	8.375	2.312	4.090	7.880	0.500	5.25	8.500	0.062	22	136,440	136,440	900	1,790
AT736	4.000	9.375	2.312	4.090	8.880	0.500	5.88	10.000	0.062	30	156,000	156,000	830	1,650
AT737	4.000	10.500	2.312	4.090	9.880	0.500	6.50	14.000	0.062	39	196,470	196,470	770	1,540
AT738	5.000	8.500	2.312	5.130	7.880	0.500	6.00	7.375	0.062	18	109,390	109,390	830	1,650
AT739	5.000	9.500	2.312	5.130	8.880	0.500	6.13	10.500	0.062	26	159,120	159,120	770	1,540
AT740	5.000	10.500	2.625	5.130	9.880	0.560	6.25	12.750	0.125	39	200,280	200,280	720	1,430
AT741	5.000	11.500	2.625	5.130	10.880	0.560	7.00	16.000	0.125	50	236,280	236,280	670	1,340
AT742	5.000	12.500	2.625	5.130	11.880	0.560	7.25	19.750	0.125	63	335,330	1,144,000	630	1,260
AT743	6.000	9.500	2.625	6.130	8.750	0.560	7.25	6.750	0.125	23	127,970	450,100	720	1,430
AT744	6.000	10.500	2.625	6.130	9.750	0.560	7.38	9.500	0.125	33	190,300	641,840	670	1,340
AT745	6.000	11.500	2.625	6.130	10.750	0.560	7.38	13.500	0.125	44	228,860	923,160	630	1,260
AT746	6.000	12.500	2.625	6.130	11.750	0.560	7.50	17.000	0.125	57	262,360	1,088,020	600	1,190
AT747	7.000	10.500	2.625	7.130	9.750	0.560	8.13	8.125	0.125	26	151,500	546,420	630	1,260
AT748	7.000	11.500	2.625	7.130	10.750	0.560	8.25	11.500	0.125	37	209,390	783,390	600	1,190
AT749	7.000	12.500	2.625	7.130	11.750	0.560	8.25	15.375	0.125	50	247,920	1,015,470	570	1,130
AT750	7.000	14.750	4.000	7.190	13.750	0.880	9.00	15.375	0.250	118	428,070	1,583,420	510	1,020
AT751	8.000	12.750	4.000	8.190	11.750	0.880	9.38	8.500	0.250	63	254,160	939,870	540	1,080
AT752	8.000	14.750	4.000	8.190	13.750	0.880	10.38	12.000	0.250	106	390,790	1,476,330	490	980
AT753	8.000	16.875	4.000	8.250	15.750	0.880	10.50	19.500	0.250	154	507,980	2,056,050	450	900
AT754	10.000	16.875	4.000	10.250	15.750	0.880	11.50	16.750	0.250	120	431,150	1,734,480	410	830
AT755	10.000	18.875	5.000	10.250	17.750	1.130	12.00	20.000	0.250	225	603,350	2,680,890	380	770
AT756	10.000	20.875	5.000	10.250	19.750	1.130	13.25	24.000	0.250	300	757,260	3,227,020	360	720
AT757	12.000	18.875	5.000	12.250	17.750	1.130	13.63	15.375	0.250	180	463,250	2,022,690	360	720
AT758	12.000	20.875	6.000	12.250	19.750	1.380	13.88	20.000	0.250	300	714,040	2,937,800	340	670
AT759	12.000	24.875	6.000	12.250	23.750	1.380	16.00	28.500	0.250	510	1,029,760	4,652,910	300	600
AT760	14.000	20.875	4.875	14.250	19.750	1.130	15.50	19.500	0.250	200	532,480	2,374,460	320	630
AT761	14.000	22.875	4.875	14.250	21.750	1.130	15.50	28.500	0.250	280	722,020	3,319,190	300	600
AT762	14.000	24.875	4.875	14.250	23.750	1.130	16.38	36.125	0.250	370	848,180	4,280,300	280	570
AT763	16.000	22.875	6.000	16.250	21.500	1.380	17.50	17.500	0.250	270	601,150	2,346,990	280	570
AT764	16.000	25.000	6.000	16.250	23.500	1.380	18.00	23.500	0.250	385	878,700	3,788,720	270	540
AT765	16.000	27.000	6.000	16.250	25.500	1.380	18.50	29.625	0.250	510	1,027,320	4,885,840	260	510
AT766	18.000	27.000	6.750	18.380	25.500	1.500	19.50	23.500	0.250	470	939,680	3,905,990	240	490
AT767	18.000	29.000	6.750	18.380	27.500	1.500	20.00	29.625	0.250	620	1,190,250	5,363,260	230	470
AT768	18.000	31.000	7.250	18.380	29.500	1.500	20.63	36.125	0.250	840	1,554,140	6,720,410	220	450

### Cylindrical Roller Thrust Crane Hook Series With and Without Grease Fitting...

- Special Design for Crane Hook Applications.
- Designed to Fit Standard Hook Shanks.
- Steel “Weathershed” to Keep Out Contaminants.
- Available With or Without Grease Fittings.
- Bearing Capacity is the Static Load Rating Based on a Permanent Deformation of .0002 inch per inch of Roller Diameter.

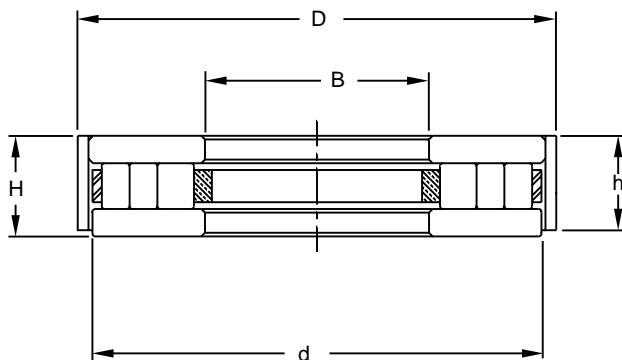

CT Type

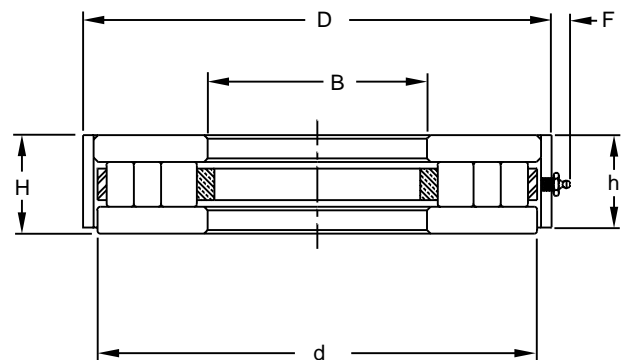

WCT Type

Basic Bearing Number		Designed Hook Shank	Bore	Outside Diameter D		Height H	Internal Dimensions		Bearing Capacity
Grease Fitting				B	CT		WCT *	d	
None	Installed								
CT-11	WCT-11	1 5/8	1.640	3.093	3.343	0.812	2.95	0.69	36,890
CT-16	WCT-16	1 15/16	1.952	3.468	3.593	0.812	3.22	0.69	65,310
CT-17	WCT-17	2	2.015	3.937	4.000	1.000	3.60	0.88	73,210
CT-19	WCT-19	2 1/4	2.265	4.000	4.250	1.000	3.86	0.88	72,970
CT-20-C	WCT-20-C	2 1/4	2.265	4.250	4.375	1.000	3.98	0.88	88,600
CT-23	WCT-23	2 3/4	2.765	4.750	4.843	1.000	4.45	0.88	93,820
CT-24-A	WCT-24-A	2 3/4	2.765	4.875	5.156	1.250	4.76	1.13	121,300
CT-27-A	WCT-27-A	3 1/4	3.265	6.125	6.250	1.500	5.85	1.38	180,810
CT-27-C	WCT-27-C	3 1/4	3.265	6.187	6.375	1.750	5.97	1.63	212,960
CT-27-B	WCT-27-B	3 1/2	3.515	6.156	6.375	1.625	5.97	1.50	203,410
CT-28-A	WCT-28-A	3 1/2	3.515	6.750	6.937	1.625	6.54	1.50	245,110
CT-34-A	WCT-34-A	3 3/4	3.765	7.125	7.250	1.875	6.86	1.75	288,080
CT-35-A	WCT-35-A	4 1/4	4.265	8.171	8.375	2.000	7.97	1.88	369,200
CT-38-A	WCT-38-A	4 1/2	4.515	8.125	8.312	2.000	7.91	1.88	390,910
CT-39-A	WCT-39-A	5	5.015	9.156	9.375	2.250	8.97	2.13	628,470
CT-44-A	WCT-44-A	5 1/2	5.515	10.500	10.500	2.500	10.10	2.38	628,470
CT-45-A	WCT-45-A	6	6.015	11.156	11.375	3.000	10.97	2.75	923,160
CT-49-A	WCT-49-A	6 13/16	6.827	12.750	12.750	2.500	12.34	2.38	1,004,880

\* Dimension Fx2 must be added to bearing O.D. for determining overall O.D. on WCT type.  
F = .41 inch (approx.) for all sizes.

## *Tapered Thrust Bearings...*

### **TTHD Style**

ROLLWAY® Tapered Thrust Bearings (TTHD Style) are engineered for efficiency under the harshest industrial conditions. These bearings feature tapered rollers positioned between two plates with tapered raceways. The tapered thrust differs significantly from the cylindrical roller thrust as there is true rolling motion with the vertex of the conical sections intersecting the bearing axis. When the bearing is loaded, the rollers exhibit an outward force that is countered by the plate's outer guide rib. The large end of the roller and the guide rib are spherically ground and matched to minimize loading and friction between the two components. The large spherical end of the roller is counterbored to improve lubrication between the roller and guide rib. By virtue of the additional contact surface these bearings will have a higher dynamic capacity than a similar sized cylindrical roller thrust bearing.

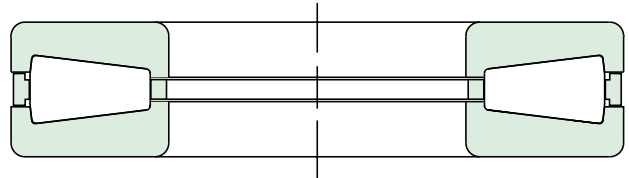

### **T-FLAT (TTVF) Style**

The T-Flat is similar to the TTHD style except one plate is flat. The guide rib on the one tapered raceway resists the induced radial force component caused by the inclined plane while the flat plate allows radial displacement without adversely affecting bearing operation. Maximum capacity is achieved through close spacing of rollers through the use of a steel, pin type retainer.

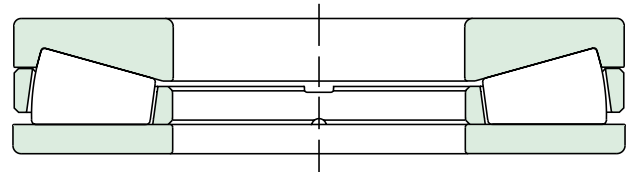

## *Basic Bearing Design... Tapered Thrust Bearing Components*

### **Plates and Rolling Elements...**

The plates and rollers are made from carburizing grade steel hardened to Rc 58 min., with the core hardness maintained at Rc 30 min. Upon request we can manufacture the components from CEVM or VIMVAR grades of material.

All thrust plates are accurately ground for flatness and parallelism of roller riding and backing surfaces. Locating diameters are ground to obtain an accurate fit on the shaft or in the housing. The surfaces of the plates are ground to provide a long operating life. The guide rib on the tapered plates is spherically ground to match the roller and reduce friction. All tapered thrust plates are designed to be used with a full complement of rollers which makes it possible to supply this version for any size.

All rolling elements are precision ground and graded to provide an even distribution of load over the contact surfaces. Rollers are crowned for optimum contact stress patterns by reducing the end stress between the roller and the thrust plates. The large ends of the rollers are spherically ground. This provides controlled contact between the rollers and the guide rib, thus enhancing the flow of lubricant.



## *Basic Bearing Design... Tapered Thrust Bearing Components*

### **Retainers...**

The TTHD taper thrust bearing retainers are machined from a single piece of centrifugally cast brass. The retainer is designed to pilot on the thrust plates' flanges. The roller pockets are accurately machined at right angles to the thrust force which will be applied to the bearing.

The T-Flat retainers are "pin through" style (pins extend through the center of the roller). The retainer consists of two steel rings through which the hardened steel pins are secured. An alternate design is a retainer machined from a single piece of centrifugally cast brass with the rollers retained by two pins.

### *Superior Performance In Horizontal Shaft Applications...*

Tapered thrust bearings have been found to have superior performance in horizontal shaft applications. The self centering action of the rollers counteract the gravitational effect of the roller assembly, thus reducing the possibility of a bearing failure resulting from the roller assembly contacting the shaft.

### *True Rolling Motion...*

By virtue of their design, tapered thrust bearings provide true rolling motion when compared to cylindrical thrust bearings whose rollers tend to have a minimal amount of slippage due to the fundamental design.

### *Tapered Thrust Bearings Maximizing Load For A Given Envelope...*

For a given shaft size and approximate envelope, the **Tapered Thrust** bearing's *dynamic capacity is considerably greater than a Cylindrical Roller Bearing.*

See the example shown below.

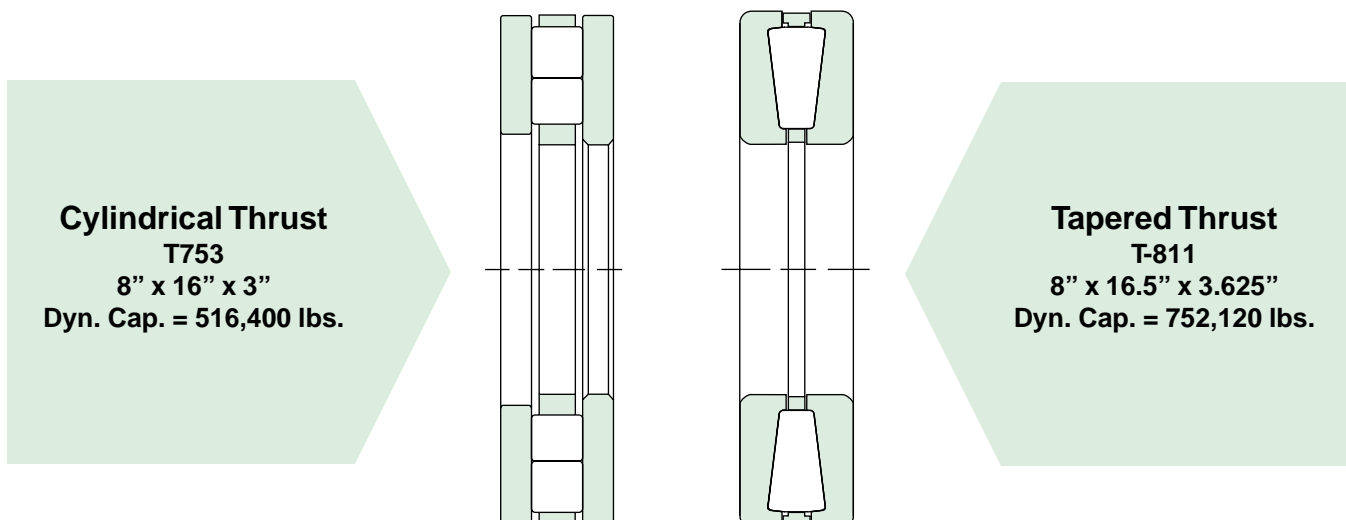

### Nomenclature... Tapered Thrust

#### TTHD Nomenclature

Example:

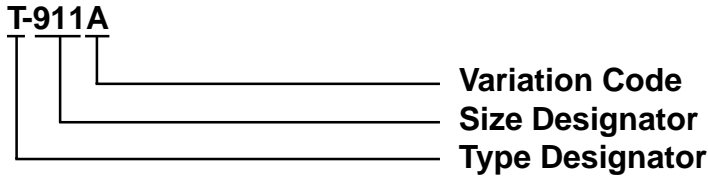

#### TYPE DESIGNATOR

T ..... TTHD Style Thrust.

#### SIZE DESIGNATOR

Reference catalog for sizes.

#### VARIATION CODES

- **A** - Variation from standard - consult catalog or engineering.
- **F** - Full complement of rollers.
- **V** - Bearing plates and rollers made from VIMVAR or CEVM steel.

#### T-Flat (TTVF) Nomenclature

Example:

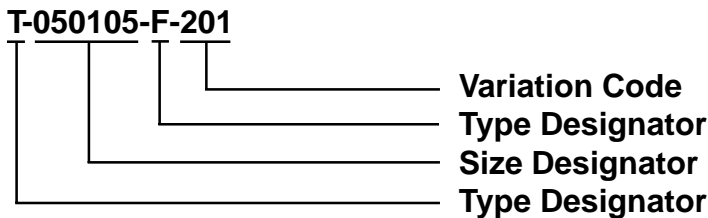

#### TYPE DESIGNATOR

T--F - TTVF Style

T--FS - TTVF Style with 2 piece aligning plate.

#### SIZE DESIGNATOR

Bearing Bore and Outside Diameter size. The first three digits are the bore size and the second three digits are the O.D size. Example: 050105 refers to a 5 inch bore and 10.5 inch O.D.

#### VARIATION CODES

**201 to 215** are numerically assigned codes that designate the variation from standard (example 201 = 1st variation, 202 = 2nd variation, etc.). These bearing code numbers do not reference the modification from standard. Engineering must be contacted for information concerning a particular modification.

### Tapered Thrust Bearings...

- TTHD Style Tapered Roller Thrust Bearings.
- Standard Inch Series.
- Machined Centrifugally Cast Brass Retainers.
- Crowned Rollers.
- Plates and Rollers of Carburized Steel.

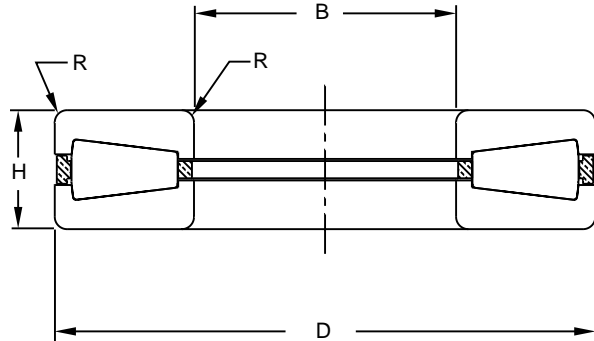

#### Typical Applications:

Extruders, Pulverizers, Pumps, Swivels and Industrial & Marine Gear Boxes.

BASIC BEARING NUMBER	BORE B	OUTSIDE DIAMETER D	HEIGHT W	HOUSING & SHAFT FILLET R	EST. WEIGHT	CAPACITY		LIMITING SPEED OIL BATH
						DYNAMIC C	STATIC C <sub>0</sub>	
						POUNDS		
T-411	4.000	8.500	1.813	0.13	20	219,100	762,700	1070
T-511	5.000	10.500	2.313	0.19	37	322,500	1,232,570	860
T-511A	5.063	10.500	2.313	0.19	37	322,500	1,232,570	860
T-611	6.000	12.500	2.750	0.25	66	455,125	1,672,410	725
T-661	6.625	12.000	2.750	0.25	56	382,620	1,323,000	720
T-691	6.875	14.125	3.250	0.25	93	539,980	2,023,000	640
T-711	7.000	14.500	3.250	0.31	109	601,700	2,101,000	625
T-811	8.000	16.500	3.625	0.38	132	752,120	2,879,160	550
T-9020	9.000	17.000	3.495	0.38	136	744,400	2,883,000	510
T-911	9.000	19.000	4.125	0.44	237	991,250	3,796,762	475
T-911A	9.250	19.000	4.125	0.44	232	991,250	3,796,762	475
T-921	9.250	21.500	5.000	0.63	351	1,361,600	5,346,100	435
T-1011	10.000	21.250	4.625	0.44	320	1,230,400	4,874,000	425
T-1120	11.000	23.750	5.375	0.44	490	1,573,660	6,286,210	385
T-16050	16.000	33.000	7.000	0.50	1165	2,877,500	11,295,180	275

### T-Flat Thrust Bearings...

- TTVF Style Tapered Roller Thrust Bearings.
- Standard Inch Series.
- Aligning Style Available - Allows for 3° Initial Static Misalignment.
- Machined Brass or Pin Type Retainers.
- Crowned Rollers.
- Plates and Rollers of Carburized Steel.

#### Typical Applications:

Extruders, Pulverizers, Pumps and Swivels.

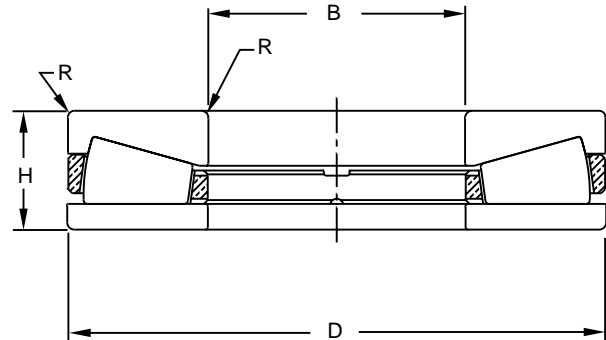

#### Standard T-Flat Thrust Bearing

BASIC BEARING NUMBER	BORE B	OUTSIDE DIAMETER D	HEIGHT W	HOUSING & SHAFT FILLET R	CAPACITY	
					DYNAMIC C	STATIC C <sub>0</sub>
					POUNDS	
T-050105-F	5.0000	10.5000	2.3125	0.14	292,000	594,000
T-070140-F	7.0000	14.0000	4.5000	0.19	523,000	1,243,000
T-072160-F	7.2500	16.0000	8.0000	0.19	979,000	1,851,000
T-090190-F	9.0000	19.0000	5.7500	0.25	1,326,800	2,473,000
T-101215-F	10.1000	21.5000	6.5000	0.25	1,777,000	3,352,000
T-120240-F	12.0000	24.0000	4.5000	0.25	1,660,000	3,994,000
T-140260-F	14.0000	26.0000	9.1250	0.31	2,219,000	4,467,000
T-170340-F	17.0000	34.0000	9.0000	0.38	4,010,000	8,500,000

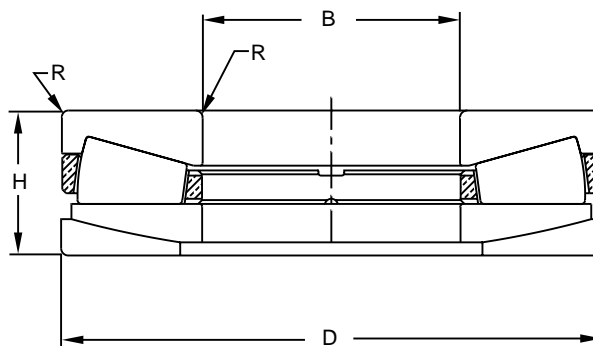

#### Self Aligning T-Flat Thrust Bearing

BASIC BEARING NUMBER	BORE B	OUTSIDE DIAMETER D	HEIGHT W	HOUSING & SHAFT FILLET R	CAPACITY	
					DYNAMIC C	STATIC C <sub>0</sub>
					POUNDS	
T-090190-FS	9.0000	19.0000	6.2500	0.36	1,320,000	2,440,000
T-095192-FS	9.5000	19.2500	6.0000	0.36	1,120,000	2,240,000
T-100200-FS	10.0000	20.0000	8.5000	0.24	1,350,000	2,200,000
T-120240-FS	12.0000	24.0000	8.5000	0.25	2,250,000	4,010,000
T-140260-FS	14.0000	26.0000	10.0000	0.40	2,490,000	4,180,000
T-140260-FS	16.0000	34.2500	9.5000	0.40	3,980,000	6,770,000

## Tandem Thrust Bearings...

**ROLLWAY® Tandem Thrust Bearings**, also referred to as “Multi-Stage Thrust” bearings, were originally designed and patented by ROLLWAY Bearing Corp. in 1945, Patent #2374820.

The bearing consists of a series of thrust plates and roller assemblies with compression sleeves separating the stages. The component design and overall match grinding make this bearing unique. The design of the sleeves along with the precision match grinding of the components allows the load to be equally applied through the stages of the bearing.

Tandem thrust bearings are designed to be used in horizontal shaft applications (extruder gear drives) and it is essential that a sufficient thrust load be applied to prevent roller slip. Typically, the minimum load required is expressed as a ratio of the bearing’s dynamic load rating (C) to the applied load (P). Loads representing  $C/P > 12$  **must** be avoided and loads where  $C/P$  falls between 8 and 12 **should** be avoided.

The Tandem design allows the use of a high thrust capacity bearing in a small area. It was originally designed for a rotary swivel used on an oil drilling rig. Later these bearings were adopted by plastics and rubber manufacturers for use in single screw extruders utilizing 2 and 3 stage bearings. The tandem design enabled the extruder manufacturers to increase the output of the machines without increasing the size of the gear boxes. This allowed their customers to have a higher output machine without taking up more floor space. These bearings are used in twin screw extruders as well. Twin screw extruders have two parallel shafts very close to each other, making the use of the tandem thrust bearing essential. Some twin screw extruder designs use eight stage tandem thrust bearings. We manufacture two, three, four, six and eight stage bearings in both inch and metric series. Bore sizes range from about 1 to 22 inches with corresponding outside diameters ranging from 3.5 to 42 inches. ROLLWAY® tandem thrust bearings are supplied to original equipment manufacturers and the aftermarket.

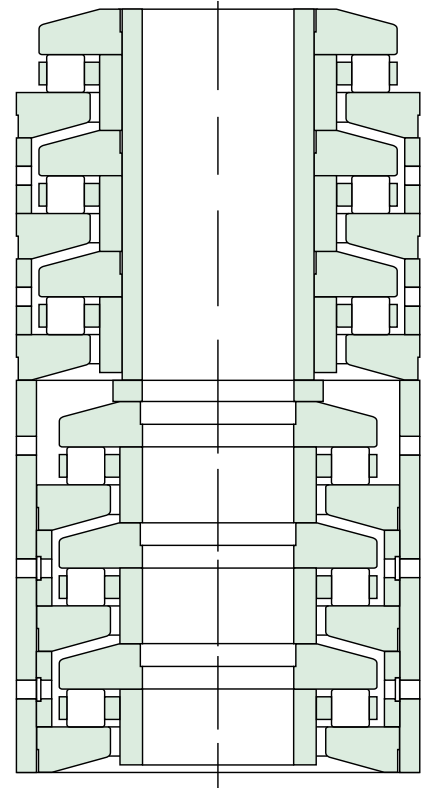

### Minimal Backing Support Requirements...

The tandem thrust design permits the use of minimal shaft and housing shoulders required by some applications. The cantilevering action of the thrust plates and use of compression sleeves enable these bearings to be used effectively where only minimal shaft and housing shoulder exist.

### Maximizing Footprint...

The use of a tandem thrust bearing enables the designer to create a gearbox with high thrust capacity within a small space. The end result is a gearbox with a smaller footprint. The drawing to the right is a comparison of three different thrust bearings of equivalent dynamic capacity. This illustrates the dramatic reduction in outside diameter associated with the tandem thrust bearings.

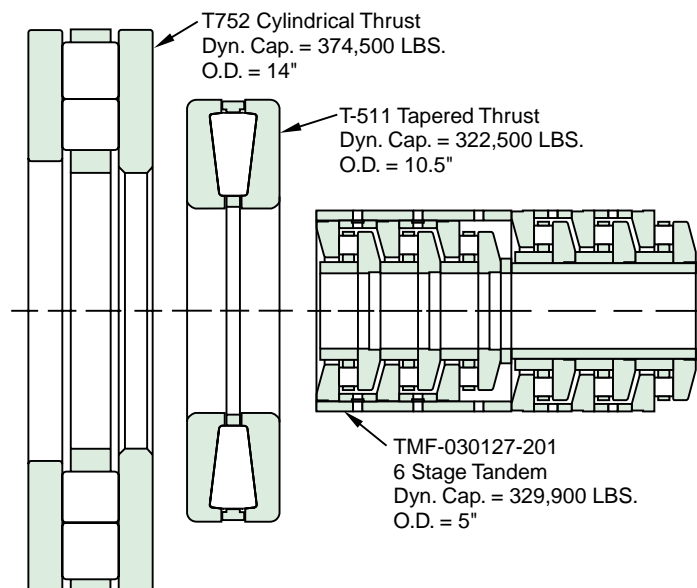

## Tandem Thrust Bearings Designs...

### Availability . . .

ROLLWAY® Tandem Thrust Bearings are essentially designed to order, however, many sizes have become standard production items. ROLLWAY® Tandem Thrust Bearings can be designed in either inch or metric sizes, 2 to 8 stages with sizes ranging from inside diameters about 1 inch to outside diameters of 42 inches. We support existing tandem designs by providing replacement bearings and bearing reconditioning as required. Some of the more popular sizes are maintained in inventory. The tables on the following pages identify some of the popular ROLLWAY sizes available, with the basic sizes provided for reference only. For more detailed information on a particular size contact ROLLWAY customer service or engineering department.

### New Designs...

New designs can be engineered and produced in small volume. Contact engineering for assistance in developing a tandem bearing design that will satisfy your application requirements. Based on your design envelope, loads, speeds and desired life, our engineers will design a tandem thrust bearing for your application.

## Data Provided From ROLLWAY...

**Detailed drawings are available on the listed Tandem Thrust Bearing designs.** Upon request for a specific part number a drawing will be sent containing the information in the following drawing along with the rated dynamic capacity. *Shaft and housing fits are also available upon request.*

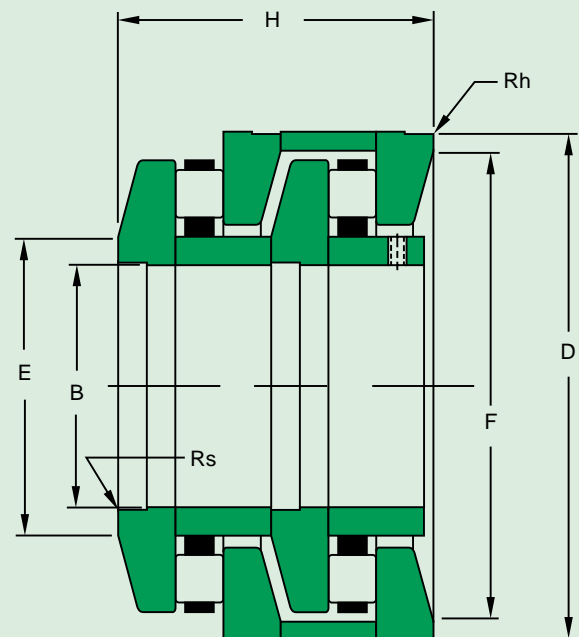



### Tandem Thrust 2 Stage...

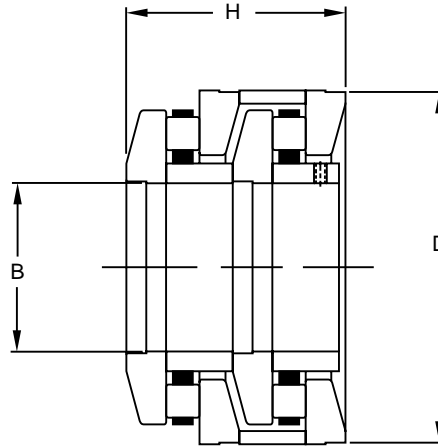

PART NUMBER	B	D	H	DYN CAP LBS
	INCH	INCH	INCH	
TAB-017043-201	1.7500	4.3765	3.8750	79,000
TAB-027047-203	2.7570	4.7035	2.6250	75,100
TAB-030066-201	3.0000	6.6265	3.6250	141,000
TAB-040082-201	4.0000	8.2515	7.0620	236,000
TAB-040100	4.0000	10.0000	5.5620	376,000
TAB-050090-202	5.0000	9.0000	5.3120	272,000
TAB-060110-280	6.0000	11.0000	7.2500	427,000
TAB-060120-201	6.0000	12.0000	6.2500	454,700
TAB-060140-201	6.0000	14.0000	6.8120	619,000
TAB-062120-201	6.2500	12.0000	5.0000	440,000
TAB-070140-204	7.0000	14.0000	7.1250	605,000
TAB-070140-205	7.0000	14.0000	7.7500	713,000
TAB-070160-201	7.0000	16.0000	9.0000	925,000
TAB-072160-202	7.2500	16.0000	9.0000	897,500
TAB-080160-201	8.0000	16.0000	7.5000	775,000
TAB-080172-201	8.0000	17.2460	9.7500	1,009,000
TAB-090190-202	9.0000	19.0000	9.5000	1,240,000
TAB-092169-203	9.2500	16.9390	7.7500	970,000
TAB-100180	10.0000	18.0000	10.5000	1,078,000
TAB-100200-202	10.0000	20.0000	8.5000	1,120,000
TAB-100200-204	10.0000	20.0000	11.7500	1,458,000
TAB-101215-204	10.1000	21.5025	12.8750	1,987,000
TAB-120240-209	12.0000	24.0000	12.5000	2,320,000
TAB-140260-201	14.0000	26.0000	13.6870	2,565,000
TAB-140280-201	14.0000	28.0000	13.2500	2,469,000
TAB-170340-201	17.0000	34.0000	17.6880	3,800,000
TAB-220420-201	22.0000	42.0000	18.8750	4,810,000



### Tandem Thrust 3 Stage...

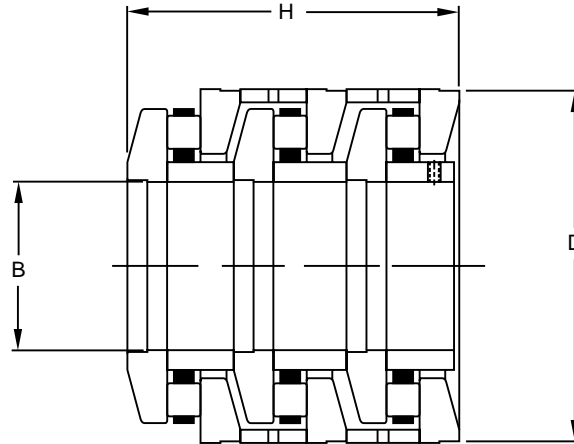

PART NUMBER	B	D	H	DYN CAP LBS
	INCH	INCH	INCH	
TAC-014035-202	1.3775	3.5433	4.3750	93,600
TAC-022094-201	2.1654	9.4488	9.4488	66,700
TAC-030053-210	3.0000	5.3880	4.2500	155,000
TAC-030066-204	3.0000	6.6265	5.6000	160,800
TAC-040100-202	4.0000	10.0000	8.1250	458,000
TAC-101215-203	10.1000	21.5025	19.2500	2,572,000
TAC-120240-207	12.0000	24.0000	21.2500	3,460,000
TAC-170340-204	17.0000	34.0000	25.5200	5,220,000

### Tandem Thrust 4 Stage...

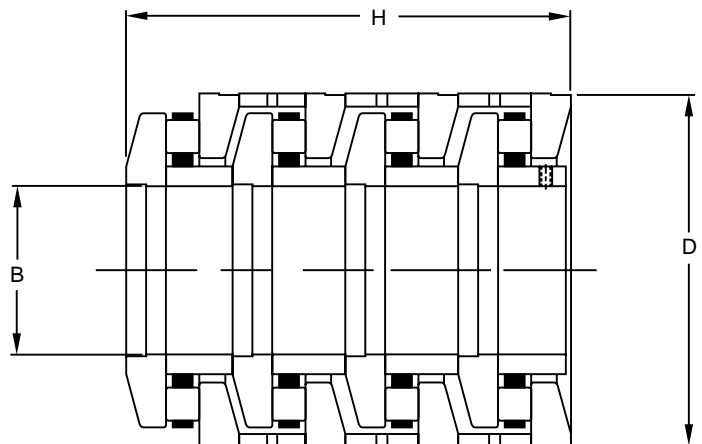

PART NUMBER	B	D	H	DYN CAP LBS
	INCH	INCH	INCH	
TMD-025100	0.9843	3.9370	5.8661	150,000
TAD-012033-204	1.1830	3.3465	4.7750	69,400
TMD-040127	1.5748	5.0000	6.9685	201,500
TAD-017047-202	1.7712	4.7235	5.9060	191,000
TAD-030082	3.0000	8.2500	10.0000	496,000
TAD-059120-201	5.9055	12.0079	12.2047	852,000



### Tandem Thrust 6 Stage...

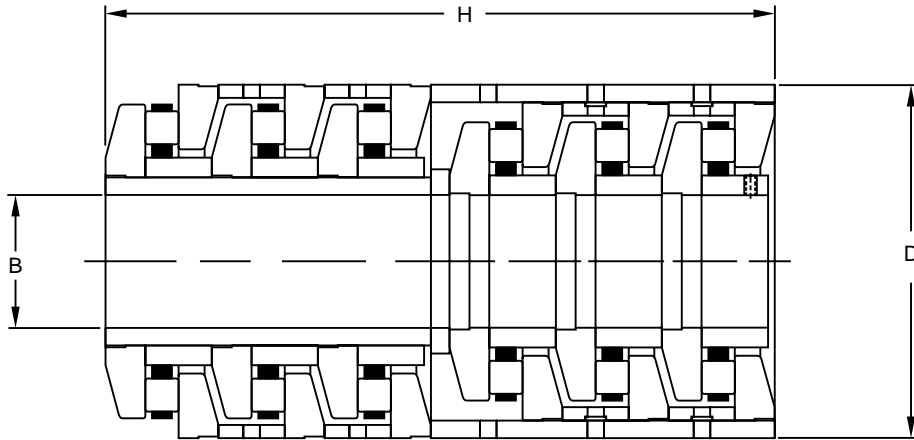

PART NUMBER	B	D	H	DYN CAP LBS
	INCH	INCH	INCH	
TMF-023090-201	0.9051	3.5433	8.2500	160,650
TMF-023090	0.9055	3.5433	8.2677	160,650
TMF-025105	0.9843	4.1339	9.7244	211,300
TAF-011028	1.1024	2.7559	5.5118	89,700
TMF-030127-201	1.1811	5.0000	11.1024	329,900
TMF-038150	1.4961	5.9055	14.1732	440,200
TAF-017063	1.7000	6.2500	10.9750	413,200
TAF-019060-201	1.8928	6.0455	9.2500	366,000
TAF-019060	1.8940	6.0480	9.2500	366,000

### Tandem Thrust 8 Stage...

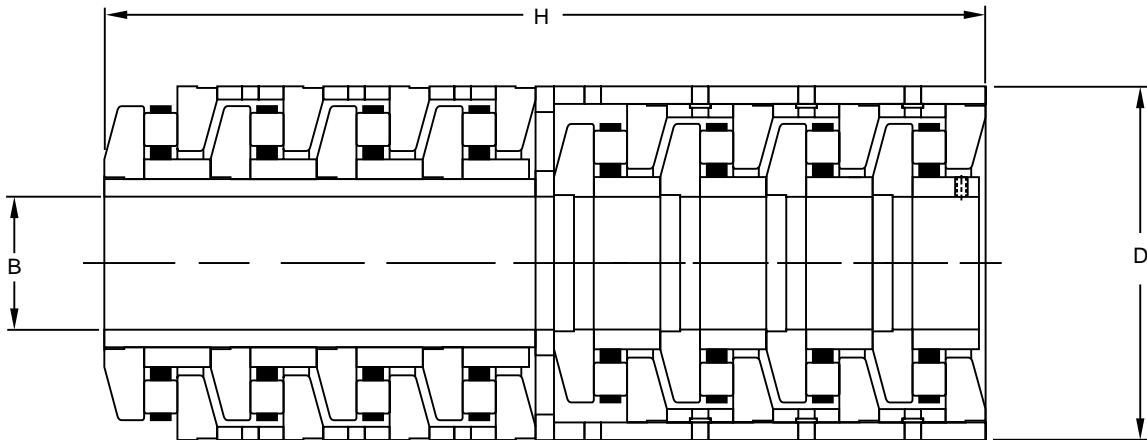

PART NUMBER	B	D	H	DYN CAP LBS
	INCH	INCH	INCH	
TMH-023090-201	0.9055	3.5433	10.6772	214,200
TMH-023092	0.9055	3.6220	12.0079	246,000
TMH-025105	0.9843	4.1339	12.5984	285,750
TMH-030127	1.1811	5.0000	14.6575	434,100
TMH-038160	1.4961	5.9055	18.2874	589,530
TMH-040170	1.5748	6.6929	19.2910	661,800
TMH-120360-201	4.7244	14.1732	35.4528	2,778,000

## Specials...

**ROLLWAY has a rich history of providing the engineered solution to tough thrust bearing problems. Our engineering staff welcomes the opportunity to design custom thrust bearings for your specialty applications.**

### Double Acting Thrust...

- Standard 600 & 700 Series.
- Aligning Style (DAT).
- Non-Aligning Style (DT).
- Simplified Double Acting (SDT).
- Special Made To Order.

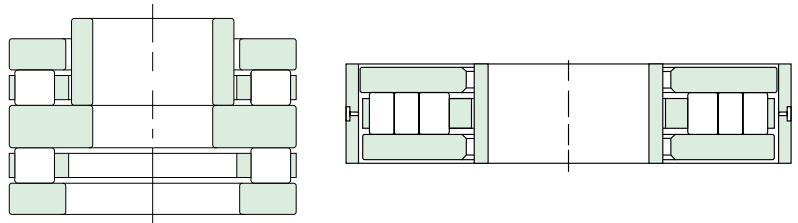

### Combination Radial - Thrust...

- Made To Order.
- Special Materials.

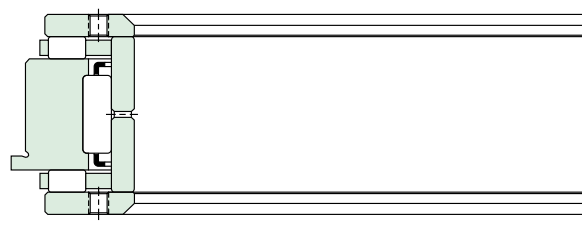

### Screw Down Thrust...

- Cylindrical Roller.
- TTHD Style.
- T-Flat Style.
- Concave and Convex Designs.

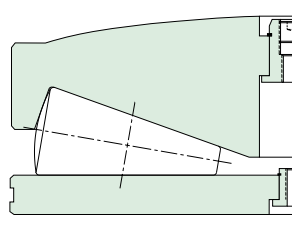

## Special Modifications and Materials...

### Standard Modifications...

- Non-Typical sizes, range from 1" I.D. to 42" O.D.
- Metric 29000 Series Cylindrical Thrust to replace Spherical Thrust.
- Anti-Rotation Features.
- Plates with Brass Bushings.

### Special Modifications...

- Special Materials...
  - *Plates and Rollers - M-50 tool steel, Carburizing steel and VIMVAR grade steel.*
  - *Retainers - Cast Iron and Phenolic.*
- Special retainer designs for high speed applications.
- Cantilever designs for minimal housing and shaft shoulder contact.
- Thin Dense Nodular Chrome Plate (TDC).
- Special Custom Designs in low quantities.

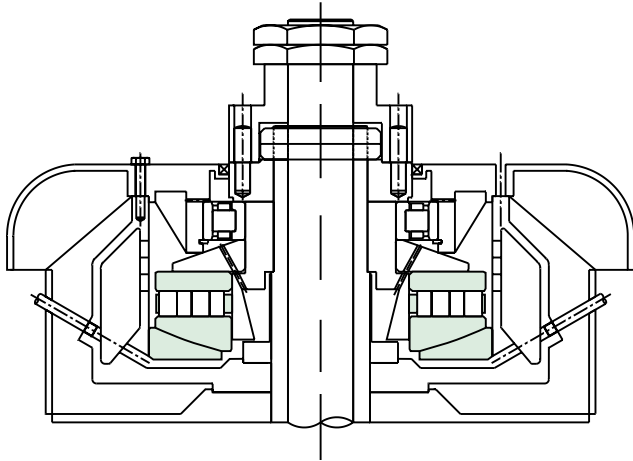

*Aligning Thrust*

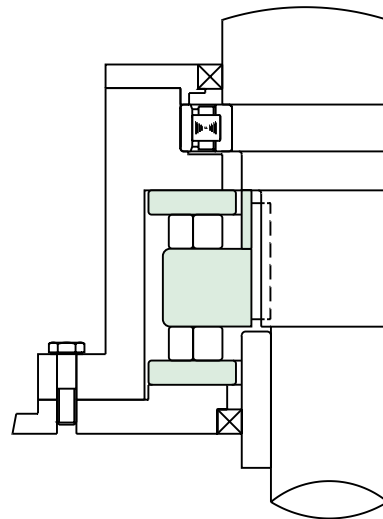

*Double Acting Thrust*

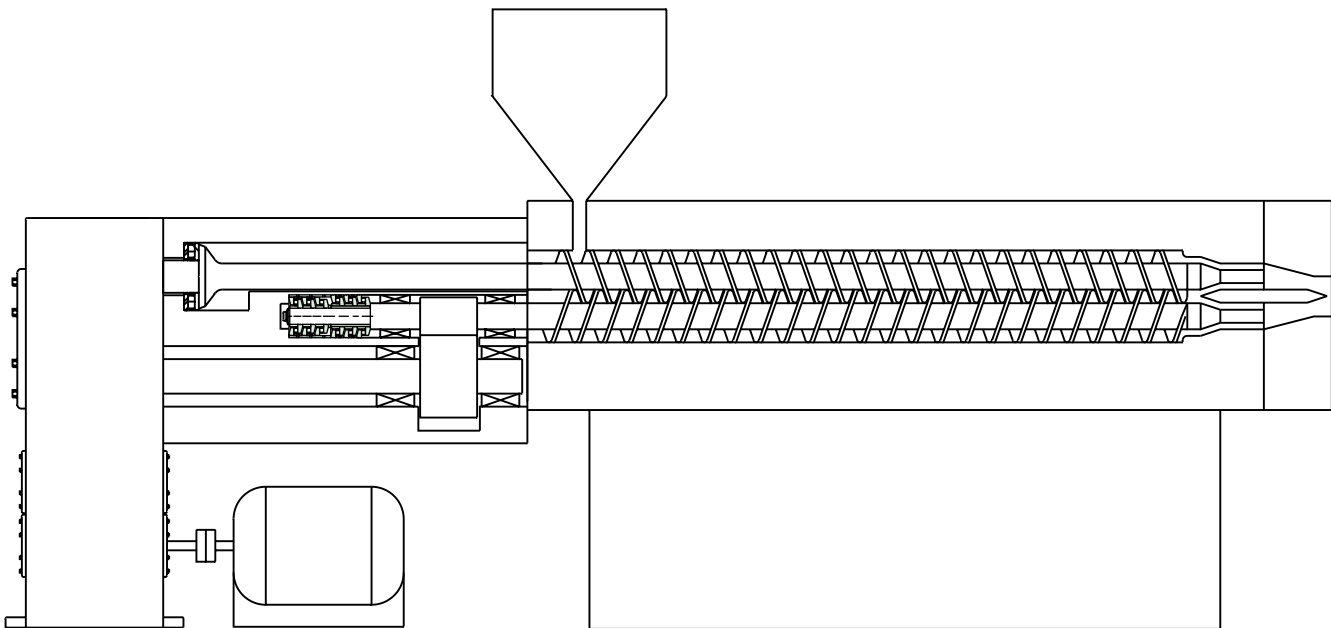

*Tandem Thrust in Twin Screw Extruder*

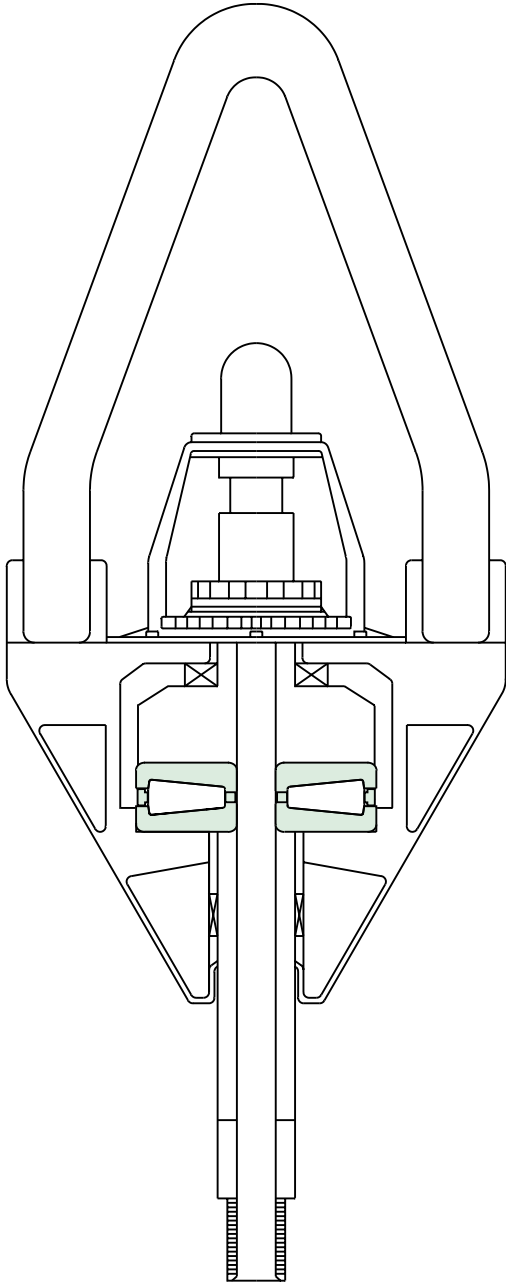

*Rotary Swivel*

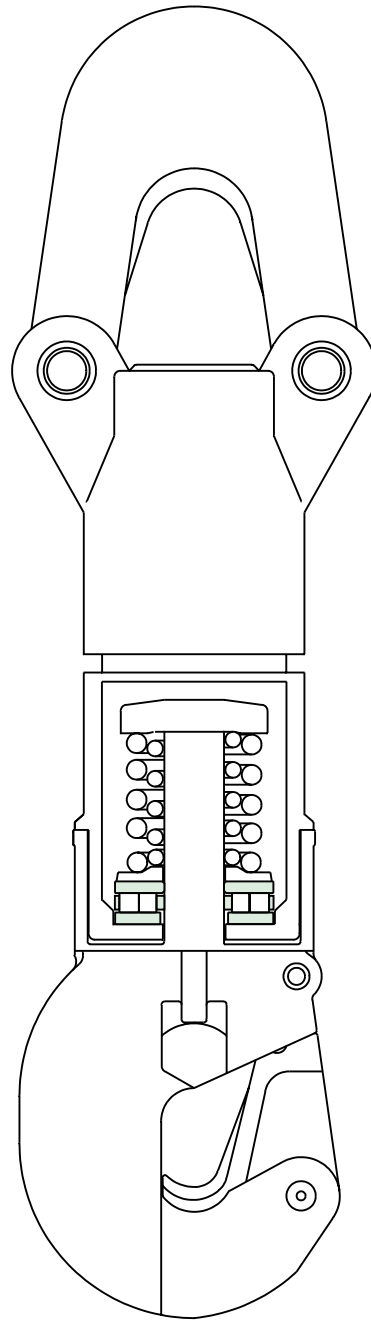

*Hook Used On Drilling Rig*

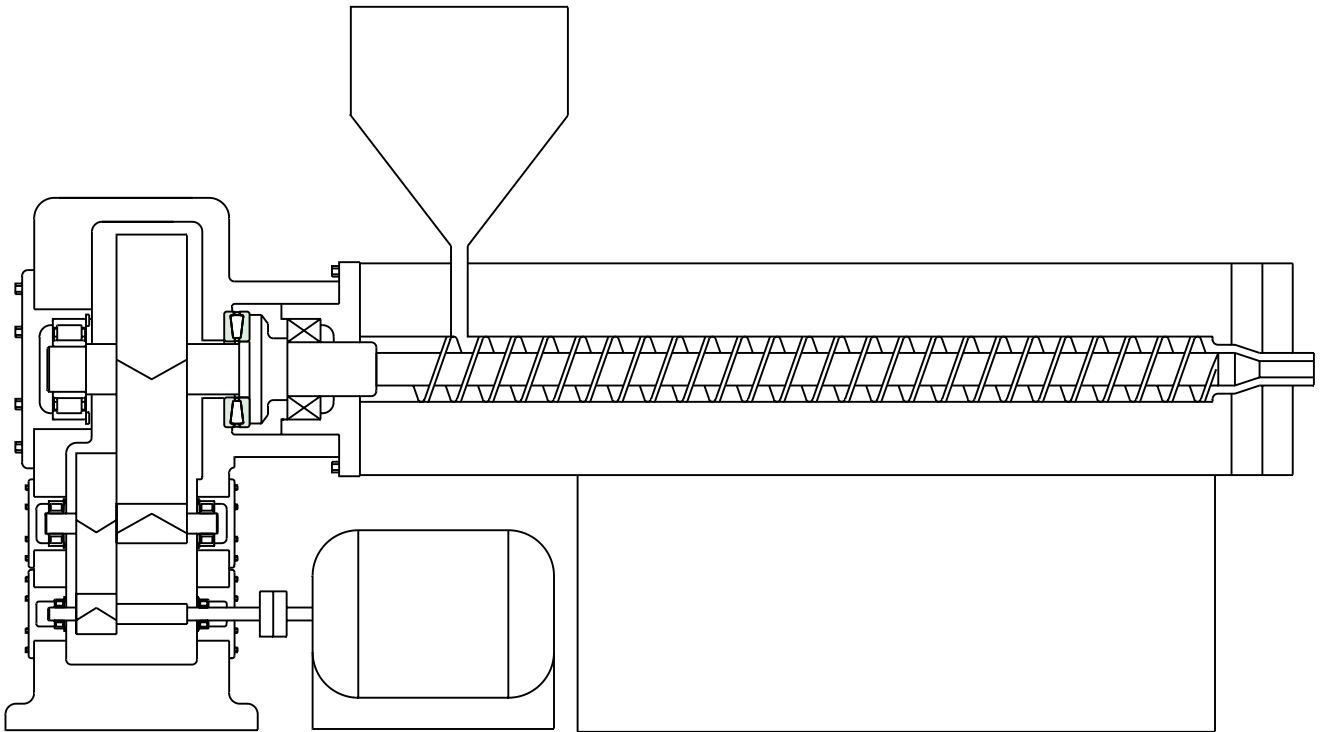

*Tapered Thrust in Single Screw Extruder*

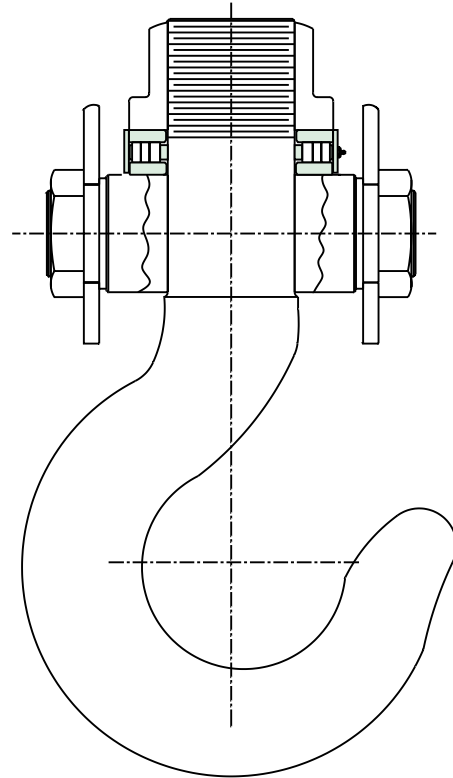
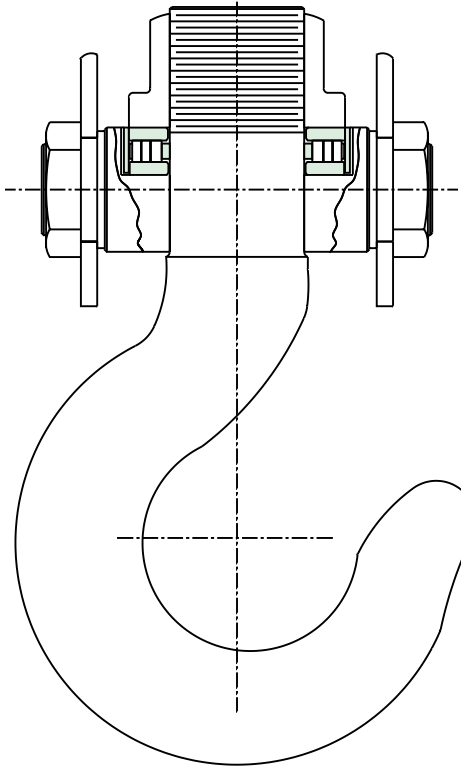

*Crane Hooks*

*Cylindrical Roller Thrust*

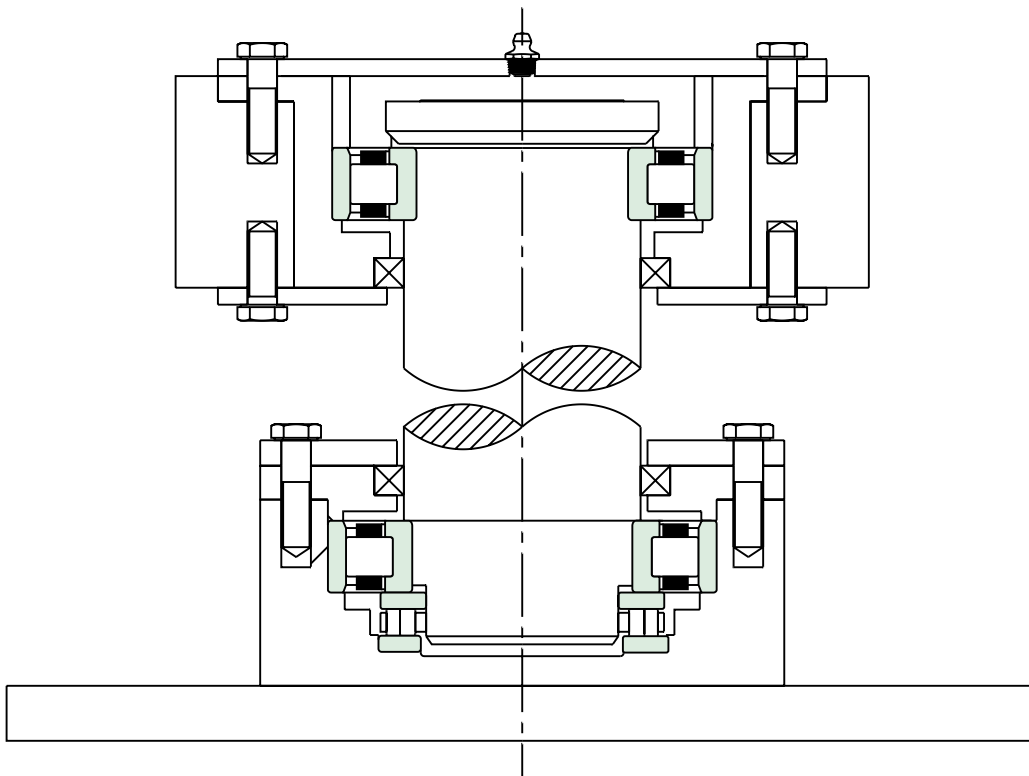



# ROLLWAY®

*Literature to help you...  
Apply, Identify, Specify and Interchange*



PL-99-1 ROLLWAY  
Bearing Product Line  
Overview

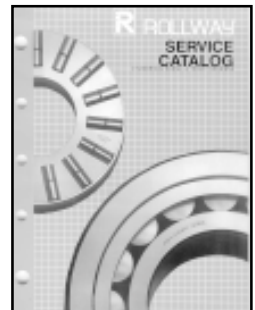

DSC597 ROLLWAY  
Service Catalog  
Identification and  
interchange guide of the  
Cylindrical and Thrust  
product lines



ROLLWAY Sphericals -  
Dimensions and capacities



Form 8678 H.O.T.™ Bearings  
High Operational Temperature  
Bearing information sheet

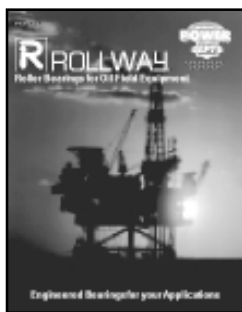

RAB-OIL99 ROLLWAY®  
Roller Bearings for  
Oilfield Equipment



Form 8594 ROLLWAY  
Wheel Bearings for  
Off-Highway Vehicle  
Electric Wheels

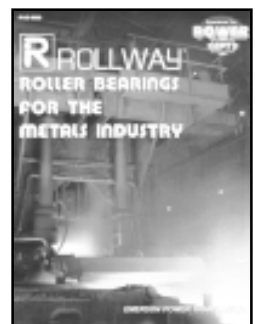

RAB-MI98 ROLLWAY® Roller  
Bearings for the Metals  
Industry



Emerson Power Transmission



Visit us on the Web today!  
[www.emerson-ept.com](http://www.emerson-ept.com)



## *Journal Roller Bearings...*

***ROLLWAY® Steel Cage Journal Bearings are the same Basic 200 and 300 Series “3 piece bearings” that we have been supplied over the past 50 years.***

- They are available as complete assemblies or as components.
- Races and Rollers are manufactured from high quality bearing grade steel and are hardened to Rc 58 minimum.
- Roller assemblies have flush ground ends.
- All outer rings are supplied with oil holes.





**ROLLWAY®**

**JOURNAL ROLLER BEARINGS**

**STEEL CAGE JOURNAL ROLLER BEARINGS**

**Steel Cage  
Journal Bearings...**  
*Are Designed and Built  
To Industry Standards.*

*They Can Be Purchased As  
Complete Assemblies  
Or As Components.*

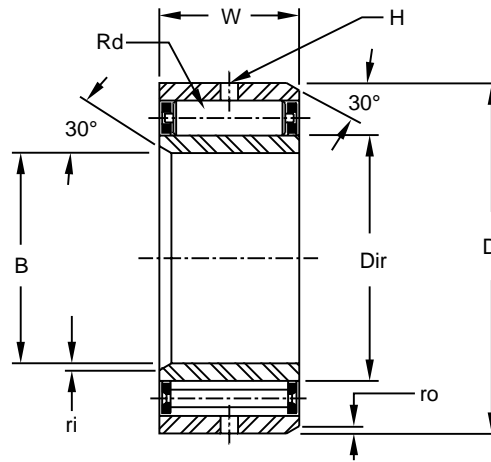

COMPLETE ASSEMBLY	COMPONENTS			B MM	D MM	W IN.	Dir IN.	Rd IN.	ri IN.	ro IN.	H IN.
	INNER RING	OUTER RING	ROLLER ASSEMBLY								
D-305-18	E-305-18-60	B-305-18-70	WS-305-18	25	62	1 1/8	1 1/4	0.4375	0.062	0.062	0.25
D-206-13	E-206-13-60	B-206-13-70	WS-206-13	30	62	13/16	1 1/2	0.3125	0.062	0.062	0.25
D-206-18	E-206-18-60	B-206-18-70	WS-206-18	30	62	1 1/8	1 1/2	0.3125	0.062	0.062	0.25
D-207-15	E-207-15-60	B-207-15-70	WS-207-15	35	72	15/16	1 3/4	0.375	0.062	0.062	0.25
D-207-19	E-207-19-60	B-207-19-70	WS-207-19	35	72	1 3/16	1 3/4	0.375	0.062	0.062	0.25
D-307	E-307-60	B-307-70	WS-307	35	80	1 3/8	1 3/4	0.5	0.062	0.062	0.25
D-208-16	E-208-16-60	B-208-16-70	WS-208-16	40	80	1	2	0.375	0.078	0.078	0.25
D-208-22	E-208-22-60	B-208-22-70	WS-208-22	40	80	1 3/8	2	0.375	0.078	0.078	0.25
D-209-18	E-209-18-60	B-209-18-70	WS-209-18	45	85	1 1/8	2 3/16	0.375	0.078	0.078	0.25
D-209-25	E-209-25-60	B-209-25-70	WS-209-25	45	85	1 9/16	2 3/16	0.375	0.078	0.078	0.25
D-309	E-309-60	B-309-70	WS-309	45	100	1 9/16	2 1/4	0.625	0.094	0.078	0.313
D-210-20	E-210-20-60	B-210-20-70	WS-210-20	50	90	1 1/4	2 3/8	0.375	0.078	0.078	0.313
D-210-28	E-210-28-60	B-210-28-70	WS-210-28	50	90	1 3/4	2 3/8	0.375	0.078	0.078	0.313
D-210-56	E-210-56-60	B-210-56-70	WS-210-28 (X2)	50	90	3 1/2	2 3/8	0.375	0.078	0.078	0.313
D-211	E-211-60	B-211-70	WS-211	55	100	1 5/16	2 5/8	0.4375	0.094	0.078	0.313
D-211-29	E-211-29-60	B-211-29-70	WS-211-29	55	100	1 13/16	2 5/8	0.4375	0.094	0.078	0.313
D-211-58	E-211-58-60	B-211-58-70	WS-211-58	55	100	3 5/8	2 5/8	0.4375	0.094	0.078	0.313
D-311	E-311-60	B-311-70	WS-311	55	120	1 15/16	2 3/4	0.6875	0.109	0.109	0.375
D-212	E-212-60	B-212-70	WS-212	60	110	1 7/16	2 7/8	0.5	0.094	0.094	0.313
D-212-31	E-212-31-60	B-212-31-70	WS-212-31	60	110	1 15/16	2 7/8	0.5	0.094	0.094	0.313
D-212-62	E-212-62-60	B-212-62-70	WS-212-31 (X2)	60	110	3 7/8	2 7/8	0.5	0.094	0.094	0.313
D-213	E-213-60	B-213-70	WS-213	65	120	1 1/2	3 1/8	0.5	0.109	0.109	0.375
D-213-33	E-213-33-60	B-213-33-70	WS-213-33	65	120	2 1/16	3 1/8	0.5	0.109	0.109	0.375
D-313-35	E-313-35-60	B-313-35-70	WS-313-35	65	140	2 3/16	3 1/4	0.8125	0.125	0.125	0.4375
D-313	E-313-60	B-313-70	WS-313	65	140	2 5/16	3 1/4	0.8125	0.125	0.125	0.4375
D-214-26	E-214-26-60	B-214-26-70	WS-214-26	70	125	1 5/8	3 5/16	0.5	0.109	0.109	0.375
D-214-38	E-214-38-60	B-214-38-70	WS-214-38	70	125	2 3/8	3 5/16	0.5	0.109	0.109	0.375
D-214-76	E-214-76-60	B-214-76-70	WS-214-38 (X2)	70	125	4 3/4	3 5/16	0.5	0.109	0.109	0.375
D-215	E-215-60	B-215-70	WS-215	75	130	1 5/8	3 1/2	0.5	0.109	0.109	0.375
D-215-28	E-215-28-60	B-215-28-70	WS-215-28	75	130	1 3/4	3 1/2	0.5	0.109	0.109	0.375
D-215-42	E-215-42-60	B-215-42-70	WS-215-42	75	130	2 5/8	3 1/2	0.5	0.109	0.109	0.375
D-215-84	E-215-84-60	B-215-84-70	WS-215-42 (X2)	75	130	5 1/4	3 1/2	0.5	0.109	0.109	0.375
D-315-39	E-315-39-60	B-315-39-70	WS-315-39	75	160	2 7/16	3 3/4	0.9375	0.156	0.125	0.4375
D-216	E-216-60	B-216-70	WS-216	80	140	1 3/4	3 3/4	0.5625	0.125	0.125	0.4375
D-216-29	E-216-29-60	B-216-29-70	WS-216-29	80	140	1 13/16	3 3/4	0.5625	0.125	0.125	0.4375
D-216-42	E-216-42-60	B-216-42-70	WS-216-42	80	140	2 5/8	3 3/4	0.5625	0.125	0.125	0.4375
D-216-84	E-216-84-60	B-216-84-70	WS-216-42 (X2)	80	140	5 1/4	3 3/4	0.5625	0.125	0.125	0.4375
D-316	E-316-60	B-316-70	WS-316	80	170	2 11/16	4	1	0.156	0.125	0.4375
D-217	E-217-60	B-217-70	WS-217	85	150	1 15/16	4	0.625	0.125	0.125	0.4375
D-217-44	E-217-44-60	B-217-44-70	WS-217-44	85	150	2 3/4	4	0.625	0.125	0.125	0.4375
D-317	E-314-60	B-317-70	WS-317	85	-	2 7/8	4 1/4	1	0.156	0.156	0.563



**ROLLWAY**

**JOURNAL ROLLER BEARINGS**

**STEEL CAGE JOURNAL ROLLER BEARINGS**

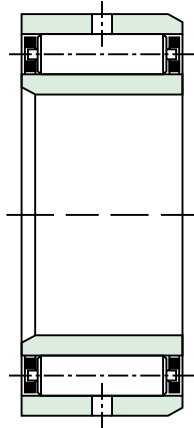

**Assembly**  
D-XXX

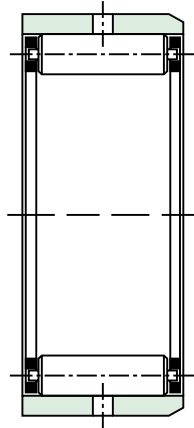

**Outer Ring & Roller**  
Assembly  
B-XXX

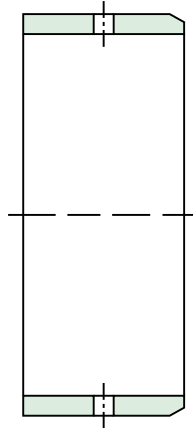

**Outer Ring**  
Only  
B-XXX-70

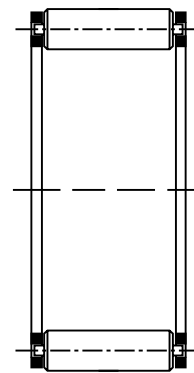

**Roller Assembly**  
Only  
WS-XXX

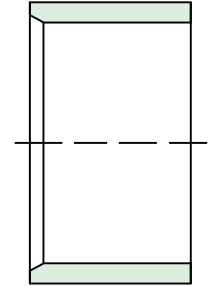

**Inner Ring**  
Only  
E-XXX-60

COMPLETE ASSEMBLY	COMPONENTS			B MM	D MM	W IN.	Dir IN.	Rd IN.	ri IN.	ro IN.	H IN.
	INNER RING	OUTER RING	ROLLER ASSEMBLY								
D-218	E-218-60	B-218-70	WS-218	90	160	2 1/16	4 1/4	0.6875	0.125	0.125	0.4375
D-218-45	E-218-45-60	B-218-45-70	WS-218-45	90	160	2 13/16	4 1/4	0.6875	0.125	0.125	0.4375
D-219	E-219-60	B-219-70	WS-219	95	170	2 3/16	4 1/2	0.75	0.156	0.125	0.4375
D-219-48	E-219-48-60	B-219-48-70	WS-219-48	95	170	3	4 1/2	0.75	0.156	0.125	0.4375
D-319	E-319-60	B-319-70	WS-319	95	200	3 1/16	4 3/4	1.125	0.187	0.156	0.563
D-319-50	E-319-50-60	B-319-50-70	WS-319-50	95	200	3 1/8	4 3/4	1.125	0.187	0.156	0.563
D-220-37	E-220-37-60	B-220-37-70	WS-220-37	100	180	2 5/16	4 3/4	0.75	0.156	0.156	0.563
D-220	E-220-60	B-220-70	WS-220	100	180	2 3/8	4 3/4	0.75	0.156	0.156	0.563
D-220-52	E-220-52-60	B-220-52-70	WS-220-52	100	180	3 1/4	4 3/4	0.75	0.156	0.156	0.563
D-220-104	E-220-104-60	B-220-104-70	WS-220-52 (X2)	100	180	6 1/2	4 3/4	0.75	0.156	0.156	0.563
D-320	E-320-60	B-320-70	WS-320	100	215	3 1/4	5	1.25	0.187	0.187	0.563
D-222-41	E-222-41-60	B-222-41-70	WS-222-41	110	200	2 7/16	5 1/4	0.875	0.156	0.156	0.563
D-222	E-222-60	B-222-70	WS-222	110	200	2 3/4	5 1/4	0.875	0.156	0.156	0.563
D-222-56	E-222-56-60	B-222-56-70	WS-222-56	110	200	3 1/2	5 1/4	0.875	0.156	0.156	0.563
D-222-112	E-222-112-60	B-222-112-70	WS-222-56 (X2)	110	200	7	5 1/4	0.875	0.156	0.156	0.563
D-322	E-322-60	B-322-70	WS-322	110	240	3 5/8	5 1/2	1.375	0.219	0.219	0.563
D-322-60	E-322-60-60	B-322-60-70	WS-322-60	110	240	3 3/4	5 1/2	1.375	0.219	0.219	0.563
D-224-45	E-224-45-60	B-224-45-70	WS-224-45	120	215	2 13/16	5 5/8	0.9375	0.156	0.187	0.563
D-224	E-224-60	B-224-70	WS-224	120	215	3	5 5/8	0.9375	0.156	0.187	0.563
D-224-62	E-224-62-60	B-224-62-70	WS-224-62	120	215	3 7/8	5 5/8	0.9375	0.156	0.187	0.563
D-324	E-324-60	B-324-70	WS-324	120	260	4 1/8	6 1/16	1.375	0.25	0.25	0.563
D-226	E-226-60	B-226-70	WS-226	130	230	3 1/8	6 1/16	1	0.156	0.187	0.563
D-226-68	E-226-68-60	B-226-68-70	WS-226-68	130	230	4 1/4	6 1/16	1	0.156	0.187	0.563
D-226-136	E-226-136-60	B-226-136-70	WS-226-68 (X2)	130	230	8 1/2	6 1/16	1	0.156	0.187	0.563
D-326	E-326-60	B-326-70	WS-326	130	280	4 3/8	6 7/16	1.5	0.25	0.25	0.563
D-228	E-228-60	B-228-70	WS-228	140	250	3 1/4	6 5/8	1.0625	0.219	0.219	0.563
D-228-76	E-228-76-60	B-228-76-70	WS-228-76	140	250	4 3/4	6 5/8	1.0625	0.219	0.219	0.563
D-228-152	E-228-152-60	B-228-152-70	WS-228-76 (X2)	140	250	9 1/2	6 5/8	1.0625	0.219	0.219	0.563
D-230	E-230-60	B-230-70	WS-230	150	270	3 1/2	7 1/16	1.1875	0.219	0.219	0.625
D-230-76	E-230-76-60	B-230-76-70	WS-230-76	150	270	4 3/4	7 1/16	1.1875	0.219	0.219	0.625
D-232	E-232-60	B-232-70	WS-232	160	290	3 7/8	7 5/8	1.25	0.25	0.25	0.625
D-232-78	E-232-78-60	B-232-78-70	WS-232-78	160	290	4 7/8	7 5/8	1.25	0.25	0.25	0.625
D-232-156	E-232-156-60	B-232-156-70	WS-232-78 (X2)	160	290	9 3/4	7 5/8	1.25	0.25	0.25	0.625
D-234-86	E-234-86-60	B-234-86-70	WS-234-86	170	310	5 3/8	8 1/16	1.375	0.25	0.25	0.688
D-234-172	E-234-172-60	B-234-172-70	WS-234-86 (X2)	170	310	10 3/4	8 1/16	1.375	0.25	0.25	0.688
D-236	E-236-60	B-236-70	WS-236	180	320	4 1/4	8 15/32	1.375	0.25	0.25	0.688
D-236-94	E-236-94-60	B-236-94-70	WS-236-94	180	320	5 7/8	8 15/32	1.375	0.25	0.25	0.688
SD-240	SE-240-60	SB-240-70	SWS-240	200	340	4 3/4	9 1/4	1.375	0.25	0.25	0.688
SD240-110	SE-240-110-60	SB-240-110-70	SWS-240-110	200	340	6 7/8	9 1/4	1.375	0.25	0.25	0.688
SD-244-110	SE-244-110-60	SB-244-110-70	SWS-244-110	220	380	6 7/8	10 7/16	1.375	0.25	0.25	0.688



## *Engineering Section...*

# **TABLE OF CONTENTS**

### **Engineering**

1. Gaging Practices .....	Page 61 & 62
2. Tolerances	
A. Radial Bearings, RBEC 1, 3 & 5 .....	Page 63 & 64
B. Journal Bearings .....	Page 64
C. Thrust Bearings .....	Page 65 thru 67
3. Life - Load - Speed .....	Page 68 thru 72
4. Fitting Practice	
A. Radial Bearing Unmounted Internal Clearance .....	Page 72 thru 75
B. Radial Bearing Mounting Practice - Shaft and Housing Fits .....	Page 76 thru 78
C. Thrust Bearing Mounting Practice - Shaft and Housing Fits .....	Page 79 thru 81
D. Journal Bearing - Shaft and Housing Fits .....	Page 82
5. Lubrication .....	Page 83 thru 87

### **ENGINEERING SUPPORT**

It is our policy to extend the facilities and experience of our Engineering Department to those who solicit advice for bearing problems. Please contact ROLLWAY Engineering Department.

Information submitted on a proposed bearing installation should be as complete as possible. The following is a guide on data to be submitted:

- A. Type of application.
- B. Magnitude and direction of bearing loads.
- C. Approximate shock loads.
- D. Data relative to speed and direction of rotation of shaft or housing.
- E. Desired life expectancy (hours).
- F. Space limitation with respect to shaft diameter, housing bore, and bearing width.
- G. Conformation of the shaft housing, and surrounding parts. This will determine the type of bearing most suitable for the application.
- H. Temperature conditions.
- I. Type of lubrication, lubricant characteristics.
- J. Information on the surrounding media if the bearing is to operate in the presence of moisture, dust, or chemicals.

It is important to include a basic assembly drawing of the application. All information submitted will be considered confidential.



## GAGING PRACTICE...

Measurement of the various dimensions and runouts can be performed in various ways by using different types of gaging equipment and with varying degrees of accuracy. The following methods are commonly employed by bearing users and, as a rule, give an accuracy sufficient for practical purposes. Bearing manufacturers may use specially designed gaging equipment to increase the accuracy and speed of gaging.

Measurements are performed by comparing the part with appropriate gauge blocks or masters which conform with those used by the National Bureau of Standards at 68° F. For this comparison, a calibrated indicator of appropriate sensitivity is used, and the part to be measured, the indicator, and the gauge block or master must be brought to the temperature of the room in which the measurements are to be made.

To avoid undue deflection of thin rings, indicator pressures should be minimized. If significant distortion is present, a load-deflection factor should be introduced to correct the measurement to the free unloaded value. In all cases when arbor methods of measuring runout are used, the rotational accuracy of the arbor must be determined so that subsequent bearing measurements may be suitably corrected if appreciable arbor inaccuracy is involved.

**Bore of Inner Race** - For determining bore diameter, use an apparatus arranged for two-point measuring. Measure single diameters in at least three angular directions and at least two radial planes. In this manner  $B_{min}$  and  $B_{max}$  are established, from which the mean diameter is obtained by:

$$B_m = \frac{B_{min} + B_{max}}{2}$$

If the size or section of the bearing inner race is such that, with the bearing axis in a horizontal position, the bore or OD measurement is influenced by gravity, the bearing should be placed with the axis in a vertical position. If necessary, a smaller gage load should be used.

**Width of Inner Race** - Support one side of the inner race on three buttons and position an indicator against the other side of the inner race directly opposite one button. Take indicator readings while rotating the inner race one revolution.

**Width Variation of Inner Race** - Use the same method as applied to measuring of the width.

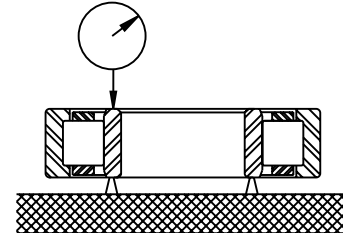

**Reference Side Runout With Bore** - Mount the bearing on an arbor having a taper of .0001 to .0002 inch in diameter per inch of length, and position the arbor between two accurate centers so that it can be rotated. Apply an indicator against the reference side of the inner race on a diameter as equal to the raceway diameter as possible. Take indicator readings while rotating the inner ring one revolution. Correction must be made for inaccuracy of the arbor.

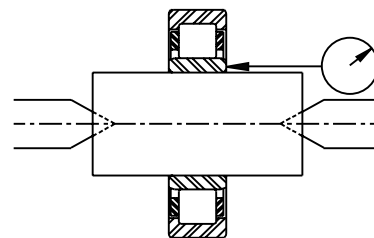

**Outside Diameter of Outer Race** - For determining outside diameter, use apparatus arranged for two-point measuring. Measure single diameters in at least three angular directions and two radial planes. In this manner  $D_{min}$  and  $D_{max}$  are established, from which the mean diameter is obtained by:

$$D_m = \frac{D_{min} + D_{max}}{2}$$

If the size or section of the bearing outer race is such that, with the bearing axis in a horizontal position, the bore or OD measurement is influenced by gravity, the bearing should be placed with the axis in a vertical position. If necessary, a smaller gauge load should be used.

**GAGING PRACTICE...**

**Width of Outer Race** - Support one side of the outer race on three buttons and position an indicator against the other side of the outer race directly opposite one button. Take indicator readings while rotating the outer race one revolution.

**Width Variation of Outer Race** - Use the same method as applied to measuring of the width.

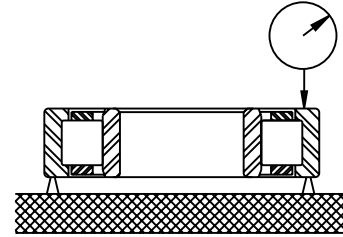

**Outside Diameter**

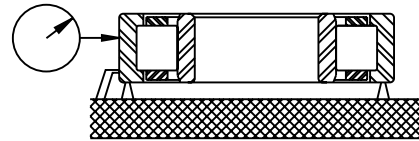
**Runout With Reference Side** - Support the reference side of the outer race and locate the outside diameter against a stop at a distance of 3.5 times the maximum housing fillet radius  $r$  (which the bearing chamfer must clear) from the lower side surface. Position an indicator directly above the stop at a distance of 3.5 times the maximum housing fillet radius  $r$  (which the bearing chamfer must clear) from the upper side surface. Take indicator readings while rotating the outer race one revolution.

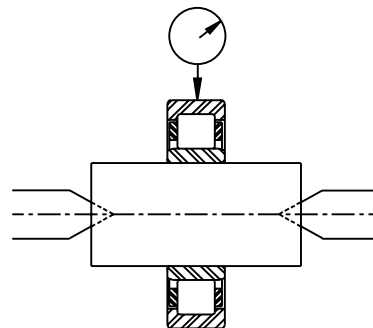

**Inner Race Radial Runout** - Mount the bearing on an arbor having a taper of .0001 to .0002 inch in diameter per inch of length and position the arbor between two accurate centers, or other suitable supports, so that it can be rotated. Place an indicator against the OD and in the plane of the centerline. Hold the outer race stationary and take indicator readings while rotating the inner race one revolution.

**Outer Race Radial Runout** - Mount the bearing on an arbor having a taper of .0001 to .0002 inch in diameter per inch of length and position the arbor between two accurate centers, or other suitable supports, so that it is firmly located. Place an indicator against the OD and in the plane of the centerline. Take indicator readings while rotating the outer race one revolution.





## TOLERANCES

### Radial Roller Bearing Tolerances...

Unless otherwise specified all ROLLWAY® Radial Roller Bearings are manufactured to ABMA's RBEC-1 Precision Class.

### Standard Tolerances RBEC-1

Bore Diameter mm		Bore Diameter inch		Bore Tolerance inch		Width Tolerance inch	
over	incl	over	incl	high (+)	low (-)	high (+)	low (-)
0	30	0.0000	1.1810	0.0000	0.0004	0.0000	0.0047
30	50	1.1810	1.9685	0.0000	0.0005	0.0000	0.0047
50	80	1.9685	3.1496	0.0000	0.0006	0.0000	0.0059
80	120	3.1496	4.7244	0.0000	0.0008	0.0000	0.0079
120	180	4.7244	7.0866	0.0000	0.0010	0.0000	0.0098
180	250	7.0866	9.8425	0.0000	0.0012	0.0000	0.0118
250	315	9.8425	12.4016	0.0000	0.0014	0.0000	0.0138
315	400	12.4016	15.7480	0.0000	0.0016	0.0000	0.0157
400	500	15.7480	19.6850	0.0000	0.0018	0.0000	0.0177
500	630	19.6850	24.8031	0.0000	0.0020	0.0000	0.0197
630	800	24.8031	31.4961	0.0000	0.0030	0.0000	0.0295

Outside Diameter mm		Outside Diameter inch		Outside Diameter Tolerance inch	
over	incl	over	incl	high (+)	low (-)
0	50	1.1811	1.9685	0.0000	0.0005
50	80	1.9685	3.1496	0.0000	0.0005
80	120	3.1496	4.7244	0.0000	0.0006
120	150	4.7244	5.9055	0.0000	0.0007
150	180	5.9055	7.0866	0.0000	0.0010
180	250	7.0866	9.8425	0.0000	0.0012
250	315	9.8425	12.4016	0.0000	0.0014
315	400	12.4016	15.7480	0.0000	0.0016
400	500	15.7480	19.6850	0.0000	0.0018
500	630	19.6850	24.8031	0.0000	0.0020
630	800	24.8031	31.4961	0.0000	0.0030
800	1000	31.4961	39.3701	0.0000	0.0039
1000	1250	39.3701	49.2126	0.0000	0.0049

### Tolerances RBEC-3

Bore Diameter mm		Bore Diameter inch		Bore Tolerance inch		Width Tolerance inch	
over	incl	over	incl	high (+)	low (-)	high (+)	low (-)
0	30	0.0000	1.1810	0.0000	0.00030	0.0000	0.0047
30	50	1.1810	1.9685	0.0000	0.00040	0.0000	0.0047
50	80	1.9685	3.1496	0.0000	0.00045	0.0000	0.0059
80	120	3.1496	4.7244	0.0000	0.00060	0.0000	0.0079
120	180	4.7244	7.0866	0.0000	0.00070	0.0000	0.0098
180	250	7.0866	9.8425	0.0000	0.00085	0.0000	0.0118
250	315	9.8425	12.4016	0.0000	0.00100	0.0000	0.0138
315	400	12.4016	15.7480	0.0000	0.00120	0.0000	0.0157
400	500	15.7480	19.6850	0.0000	0.00140	0.0000	0.0177
500	630	19.6850	24.8031	0.0000	0.00600	0.0000	0.0197

Outside Diameter mm		Outside Diameter inch		Outside Diameter Tolerance inch	
over	incl	over	incl	high (+)	low (-)
0	50	1.1811	1.9685	0.0000	0.00035
50	80	1.9685	3.1496	0.0000	0.00045
80	120	3.1496	4.7244	0.0000	0.00050
120	150	4.7244	5.9055	0.0000	0.00060
150	180	5.9055	7.0866	0.0000	0.00070
180	250	7.0866	9.8425	0.0000	0.00080
250	315	9.8425	12.4016	0.0000	0.00100
315	400	12.4016	15.7480	0.0000	0.00110
400	500	15.7480	19.6850	0.0000	0.00130
500	630	19.6850	24.8031	0.0000	0.00150
630	800	24.8031	31.4961	0.0000	0.00180



**Radial Roller Bearings**  
**Tolerances RBEC-5**

Bore Diameter mm		Bore Diameter inch		Bore Tolerance inch		Width Tolerance inch	
over	incl	over	incl	high (+)	low (-)	high (+)	low (-)
0	30	0.0000	1.1810	0.0000	0.00025	0.0000	0.0047
30	50	1.1810	1.9685	0.0000	0.00030	0.0000	0.0047
50	80	1.9685	3.1496	0.0000	0.00035	0.0000	0.0059
80	120	3.1496	4.7244	0.0000	0.00040	0.0000	0.0079
120	180	4.7244	7.0866	0.0000	0.00050	0.0000	0.0098
180	250	7.0866	9.8425	0.0000	0.00065	0.0000	0.0118
250	315	9.8425	12.4016	0.0000	0.00070	0.0000	0.0138
315	400	12.4016	15.7480	0.0000	0.00090	0.0000	0.0157

Outside Diameter mm		Outside Diameter inch		Outside Diameter Tolerance inch	
over	incl	over	incl	high (+)	low (-)
0	50	1.1811	1.9685	0.0000	0.00030
50	80	1.9685	3.1496	0.0000	0.00035
80	120	3.1496	4.7244	0.0000	0.00040
120	150	4.7244	5.9055	0.0000	0.00045
150	180	5.9055	7.0866	0.0000	0.00050
180	250	7.0866	9.8425	0.0000	0.00060
250	315	9.8425	12.4016	0.0000	0.00070
315	400	12.4016	15.7480	0.0000	0.00080
400	500	15.7480	19.6850	0.0000	0.00090
500	630	19.6850	24.8031	0.0000	0.00110
630	800	24.8031	31.4961	0.0000	0.00140

**200 & 300 Series Journal Bearings (Wide Series Tolerances)**

Bore Diameter mm		Bore Diameter inch		Bore Tolerance inch	
over	incl	over	incl	high (+)	low (-)
0	30	0.0000	1.1811	0.0000	0.0004
30	50	1.1811	1.9685	0.0000	0.0005
50	80	1.9685	3.1496	0.0000	0.0006
80	120	3.1496	4.7244	0.0000	0.0008
120	180	4.7244	7.0866	0.0000	0.0010
180	220	7.0866	8.6614	0.0000	0.0012

Outside Diameter mm		Outside Diameter inch		Outside Diameter Tolerance inch	
over	incl	over	incl	high (+)	low (-)
0	80	0.0000	3.1496	0.0005	0.0000
80	120	3.1496	4.7244	0.0006	0.0000
120	150	4.7244	5.9055	0.0008	0.00045
150	180	5.9055	7.0866	0.0010	0.0000
180	250	7.0866	9.8425	0.0012	0.0000
250	310	9.8425	12.2047	0.0014	0.0000
310	380	12.2047	14.9606	0.0016	0.0000

**Thrust Bearings**
**600 Series, Single Direction, Flat Seats**

Bore Diameter		Bore Tolerance		Height Tolerance	
over	incl	over	incl	high (+)	low (-)
0.0000	1.1870	0.0000	0.0005	0.0000	0.0060
1.1870	1.3750	0.0000	0.0006	0.0000	0.0060
1.3750	1.5620	0.0000	0.0007	0.0000	0.0060
1.5620	1.7500	0.0000	0.0008	0.0000	0.0060
1.7500	1.9370	0.0000	0.0009	0.0000	0.0060
1.9370	2.0000	0.0000	0.0010	0.0000	0.0060
2.0000	2.1250	0.0000	0.0010	0.0000	0.0080
2.1250	2.5000	0.0000	0.0011	0.0000	0.0080
2.5000	3.0000	0.0000	0.0012	0.0000	0.0080
3.0000	3.5000	0.0000	0.0013	0.0000	0.0100

Outside Diameter		Outside Diameter Tolerance	
over	incl	high (+)	low (-)
0.0000	2.8750	0.0005	0.0000
2.8750	3.3750	0.0007	0.0000
3.3750	3.7500	0.0009	0.0000
3.7500	4.1250	0.0011	0.0000
4.1250	4.7180	0.0013	0.0000
4.7180	5.0000	0.0015	0.0000

**600 Series, Single Direction, Aligning Seat With Aligning Washers**

Bore Diameter		Bore Tolerance		Height Tolerance	
over	incl	over	incl	high (+)	low (-)
0.0000	1.1870	0.0000	0.0005	0.0000	0.0060
1.1870	1.3750	0.0000	0.0006	0.0000	0.0060
1.3750	1.5620	0.0000	0.0007	0.0000	0.0060
1.5620	1.7500	0.0000	0.0008	0.0000	0.0060
1.7500	1.9370	0.0000	0.0009	0.0000	0.0060
1.9370	2.0000	0.0000	0.0010	0.0000	0.0060
2.0000	2.1250	0.0000	0.0010	0.0000	0.0080
2.1250	2.5000	0.0000	0.0011	0.0000	0.0080
2.5000	3.0000	0.0000	0.0012	0.0000	0.0080
3.0000	3.5000	0.0000	0.0013	0.0000	0.0100

Outside Diameter		Outside Diameter Tolerance	
over	incl	high (+)	low (-)
0.0000	3.0000	0.0007	0.0000
3.0000	3.3750	0.0009	0.0000
3.3750	3.6250	0.0011	0.0000
3.6250	3.8750	0.0013	0.0000
3.8750	4.5312	0.0015	0.0000
4.5312	5.0000	0.0017	0.0000



**Thrust Bearings**

**700 Series, Single Direction, Flat Seats**

Bore Diameter		Bore Tolerance		Height Tolerance	
over	incl	over	incl	high (+)	low (-)
2.0000	3.0000	0.0000	0.0010	0.0000	0.0080
3.0000	3.5000	0.0000	0.0012	0.0000	0.0100
3.5000	6.0000	0.0000	0.0015	0.0000	0.0100
6.0000	9.0000	0.0000	0.0015	0.0000	0.0150
9.0000	10.0000	0.0000	0.0018	0.0000	0.0150
10.0000	12.0000	0.0000	0.0018	0.0000	0.0200
12.0000	18.0000	0.0000	0.0020	0.0000	0.0200
18.0000	22.0000	0.0000	0.0025	0.0000	0.0250
22.0000	30.0000	0.0000	0.0030	0.0000	0.0250

Outside Diameter		Outside Diameter Tolerance	
over	incl	high (+)	low (-)
5.0000	10.0000	0.0015	0.0000
10.0000	18.0000	0.0020	0.0000
18.0000	26.0000	0.0025	0.0000
26.0000	34.0000	0.0030	0.0000
34.0000	44.0000	0.0040	0.0000

**700 Series, Single Direction, Aligning Seat With Aligning Washers**

Bore Diameter		Bore Tolerance		Height Tolerance	
over	incl	over	incl	high (+)	low (-)
2.0000	3.0000	0.0000	0.0010	0.0000	0.0100
3.0000	3.5000	0.0000	0.0012	0.0000	0.0150
3.5000	6.0000	0.0000	0.0015	0.0000	0.0150
6.0000	9.0000	0.0000	0.0015	0.0000	0.0200
9.0000	10.0000	0.0000	0.0018	0.0000	0.0200
10.0000	12.0000	0.0000	0.0018	0.0000	0.0250
12.0000	18.0000	0.0000	0.0020	0.0000	0.0250
18.0000	22.0000	0.0000	0.0025	0.0000	0.0300

Outside Diameter		Outside Diameter Tolerance	
over	incl	high (+)	low (-)
5.0000	10.0000	0.0019	0.0000
10.0000	18.0000	0.0021	0.0000
18.0000	26.0000	0.0023	0.0000
26.0000	34.0000	0.0025	0.0000
34.0000	44.0000	0.0030	0.0000

**Crane Hook**

Bore Diameter		Bore Tolerance		Height Tolerance	
over	incl	over	incl	high (+)	low (-)
0.0000	2.0156	0.0100	0.0000	0.0000	0.0080
2.0156	3.0156	0.0100	0.0020	0.0000	0.0100
3.0156	6.0156	0.0150	0.0020	0.0000	0.0150
6.0156	10.1560	0.0150	0.0050	0.0000	0.0200

Outside Diameter		Outside Diameter Tolerance	
over	incl	high (+)	low (-)
2.5000	4.0000	0.0050	0.0050
4.0000	6.0000	0.0060	0.0060
6.0000	10.0000	0.0100	0.0100
10.0000	34.0000	0.0120	0.0120

**Tapered Roller Thrust**

Bore Diameter		Bore Tolerance	
over	incl	over	incl
0.0000	12.0000	0.0010	0.0000
12.0000	24.0000	0.0020	0.0000
24.0000	36.0000	0.0030	0.0000
36.0000	48.0000	0.0040	0.0000

Outside Diameter		Outside Diameter Tolerance	
over	incl	high (+)	low (-)
0.0000	12.0000	0.0010	0.0000
12.0000	24.0000	0.0020	0.0000
24.0000	36.0000	0.0030	0.0000
36.0000	48.0000	0.0040	0.0000

Bore Diameter		Height Tolerance	
over	incl	high (+)	low (-)
ALL SIZES		0.0150	0.0150



#### DYNAMIC CAPACITY AND LIFE

Knowing the external bearing load **P**, and having selected a given bearing with a dynamic capacity **C**, the minimum life in millions of revolutions is calculated as follows:

$$L = \left(\frac{C}{P}\right)^{3.33}$$

Where:  
**C** = basic dynamic load  
**P** = equivalent load

Alternately, if a given minimum life is desired and the external bearing load is know, solving for capacity indicates the bearing size required.

Often it is necessary to know the minimum life in hours ( $L_{10}$ ) at the known speed of operation. Using the rotational speed in RPM, the  $L_{10}$  life in hours is calculated using the following equation:

$$L_{10} = \left(\frac{C}{P}\right)^{3.33} \times \frac{16,667}{n}$$

Where:  
**C** = basic dynamic load  
**P** = equivalent load  
**n** = speed of rotation RPM

This formula relates minimum life in millions of revolutions to minimum life in hours through the standard, life-hour reference base of 500 hours, and the standard speed reference base of 33 1/3 rpm, as set forth in the ABMA Standards.

The significance of the above equation is that it permits a rapid solution for minimum life in hours  $L_{10}$ , based on a known ratio of dynamic capacity to external load  $C/P$ , and a known operating speed  $n$ . Conversely, for a given required life in hours  $L_{10}$ , at a know operating speed  $n$ , the ratio  $C/P$  is thereby determined, and the bearing which is to be subjected to an external load of **P** must be selected to satisfy this latter ratio. As a general rule **the C/P ratio should not be less than 4.**

#### OPERATING CONDITIONS FACTOR

The life of a bearing is dependent on the operating conditions of the application. Lubrication, effects of the external environment, shaft and housing geometry and mounting, all have an affect on the actual bearing life. To determine a more realistic life calculation, the Operating Conditions Factor (**F**) can be included into the  $L_{10}$  life equation. The actual values determination will be based on experience of the designer and the expected operating conditions.

Using the Operating Conditions Factor (**F**) in the life equation,  $L_{10}$  life in hours now becomes:

$$L_{10} = F \times \left[ \left(\frac{C}{P}\right)^{3.33} \times \frac{16,667}{n} \right]$$

Proper selection of the **F** factor demands intimate knowledge of the application. Where little is known of the application, it is recommended that **F = 1** be selected. As a guide in selecting a realistic value for **F**, ROLLWAY suggests use of the following cumulative, individual sub-factors, **f**, to arrive at the over-all factor, **F**, thus:

$$F = f_1 \times f_2 \times f_3 \times f_4 \dots$$

The table below defines the application parameters and values recommended for derivation of the individual sub-factors.

#### Radial Bearing Factors

factor	application condition	factor estimates	
		Poor	Excellent
1	Lubricant viscosity suitability @ bearing operating temperature (see <b>Lubrication</b> )	.5	1.0
2	External environment and provisions for isolation	.5	1.0
3	Operational conditions of shaft and housing squareness & rigidity	.5	1.0
4	Machine usage; conventional rotating machinery = 1.0 reciprocating machinery = .55 impact-inducing machinery = .25	.25	1.0
5	Thrust load accompanying radial load; below permissible thrust load = 1.0 at or near permissible thrust load = .8 exceeding permissible thrust load by 25% = .5	.5	1.0

#### Thrust Bearing Factors

factor	application condition	factor estimates	
		Poor	Excellent
1	Lubricant viscosity suitability @ bearing operating temperature (See <b>Lubrication</b> )	.5	1.0
2	External environment and provisions for isolation	.5	1.0
3	Operational conditions of shaft and housing squareness & rigidity	.5	1.0
4	Bearing thrust plate backing system full backing vs partial backing	.5	1.0



#### RADIAL ROLLER BEARING THRUST CAPACITY

It is an established fact that cylindrical radial roller bearings with integral flange surfaces in the races are capable of sustaining appreciable thrust loads. Designers have recognized the existence of small thrust loads in certain applications, even though the analysis of the external forces indicates no thrust loads are present.

ROLLWAY Bearing has conducted performance and life tests on cylindrical roller bearings over a period of several years. Thrust capacity calculations shown in this catalog are based on the latest data. This research work has further established criteria for roller and race flange geometry in order to optimize performance, and life, under thrust loads.

Radial dynamic capacity is determined through a consideration of the fatigue strength of the bearing material. Thrust capacity is determined through a consideration of the sliding friction and resultant wear taking place between the roller ends and flange faces. Heat generated by the sliding friction must be effectively dissipated throughout the bearing components and by the lubricant in order to maintain thermal equilibrium at a reasonable temperature. The advantage of the cylindrical roller bearing under combined radial and thrust loads is apparent when it is observed that the radial load and the thrust load are taken by two different surfaces. In view of this, there should be no reduction in expected life, which is determined solely by the existing radial load, when thrust loads are also taken by the bearing.

Thrust capacity is dependent upon bearing design and application characteristics. Bearing design characteristics include:

- a. Apparent contact area between roller ends and mating flange surfaces.
- b. Surface finish of the mating surfaces.
- c. Geometry of the mating surfaces.
- d. Internal radial clearance and axial clearance of the roller in the roller track.

Application characteristics are a function of:

- a. Sliding velocity at the contact surfaces (rpm and bearing size).
- b. Quality and quantity of the lubricant and effectiveness of the lubrication system.
- c. Type and duration of thrust loads.
- d. Influence of the shaft and housing in heat dissipation.
- e. Operating temperatures.

A radial bearing should not be used in applications where there are essentially large thrust loads with no significant radial loads. In most applications, machine masses are of sufficient magnitude to apply a substantial radial load on the bearing without external radial forces. In these cases there will normally be sufficient radial load to allow satisfactory operation under substantial thrust loads. As a general rule, ROLLWAY **radial bearing thrust capacity is 10% of the published radial load rating.**

#### STATIC CAPACITY

The basic static capacity values in this catalog are formulated according to the industry-wide approved standards. The basic static capacity is the static load acting on a non-rotating bearing, which corresponds to a calculated contact stress at the center of the most heavily loaded rolling element raceway contact of 580,000 psi.

The concept of basic static capacity implies that the bearing will be called upon, after subjection of a static load equal to its static capacity, to perform satisfactorily at some appreciable rotational speed. Where subsequent rotation of the bearing is slow, a greater total permanent deformation can be tolerated and a greater static capacity can be used. For those cases where bearing smoothness and friction requirements are of no significance in the bearing application, and where it is evident that extremely high static loads will exist, it should be observed that the bearing fracture load is some 5 to 8 times the basic static capacity of the bearing.

#### HIGH SPEED OPERATION

The critical factors influencing the performance of radial roller bearings at very high speeds include:

- a. Retainer design, including its precision and dynamic balance.
- b. The specific lubricant, and the form and manner in which it is directed into the bearing.
- c. Basic internal radial clearance.
- d. Basic bearing design, especially the number of rollers. (Designing the maximum number of rollers into a bearing does not always improve life and performance at very high speeds.)

All of these factors must be considered in bearing applications involving high speeds, and modifications to the standard bearing may be necessary for optimum performance.



#### HIGH SPEED OPERATION - continued

Centrifugal forces affect bearing life in high speed operation. The unified theory of dynamic capacity for rolling element bearings has, as the original premise, the fact that the pattern of load distribution within a bearing is independent of the bearing operating speed. Given very high speeds in bearing applications, the centrifugal force of the rollers assumes some importance. The consequence of this is a modification of the load distribution within a bearing, and an exhibited fatigue life that cannot be estimated according to the standard life formula  $L = (C/P)^{3.33}$ . The centrifugal force exerted by the rollers results in:

- a. Additional loading of the outer race around its entire circumference.
- b. A diminution of the loaded zone on the circumference of the inner race.
- c. The possible initiation of roller skidding, with ensuing roller "frosting", accompanied by high frictional losses due to a varying retainer velocity. Incipient roller skidding occurs when the magnitude of the centrifugal force approaches the individual roller loads, considering conventional load zone.

Each of these effects causes a reduction in bearing life from that calculated conventionally. The determining factor influencing the reduction of bearing life due to very high speed is the relative magnitude of the centrifugal force exerted by the rollers which is dependent on bearing design as well as rotational speed.

If the centrifugal force is small compared with the maximum roller load, life reduction is small and life may be calculated in the usual manner. Conversely, if the centrifugal force is large compared with the maximum roller load, life reduction is appreciable, and life cannot be calculated in the usual manner. Assistance of the ROLLWAY Engineering Department will enable an accurate forecast for fatigue life to be made. Special ROLLWAY bearing designs incorporating hollow rollers are readily available for applications involving medium loads and very high speeds. The ROLLWAY® hollow roller bearings have been proven by in-house and field testing and have successfully solved many high speed application problems, especially in the range  $d_{m,n} > 1.25 \times 10^6$  and where  $C/P = 10$ .

High speed operation can also produce bearing application failure modes not associated with the fatigue life concept. In particular, rotating systems can induce conditions of instability which could result in premature bearing failure. In applications where the bearing shaft centerline experiences radial excursions, the dynamic excitation may induce objectionable noise at the very least, or, in the extreme, total bearing destruction.

Cases of seemingly moderate speeds can assume the characteristics of very high speeds on bearing operation when considering bearings in rotating planets. In this case retainer design and proper dynamic balance assume great importance.

#### VARIABLE LOAD AND SPEED

Constant bearing loads are not always encountered. Often, variable loads and/or speeds are found to exist. The machine designer will frequently use the maximum value of radial load and make the bearing selection accordingly. This results in the selection of a bearing which has more capacity than necessary. If the designer uses the arithmetical average load, then the bearing selected will have a capacity which is too low, and consequently actual life will be below expected life due to life varying inversely with the 3.33 power of the load.

It is therefore necessary that variable loads and/or speeds be resolved in such a manner as to yield a mean equivalent load which may be calculated by mathematical expressions as shown below.

Presented below are three relationships which will serve as an aid in arriving at the equivalent mean load.

(a) If speed is constant and load varies gradually over a long period of time from a certain minimum value to a larger maximum value, then:

$$P = \frac{P_{\min} + 2P_{\max}}{3}$$

(b) If speed is constant and load varies non-linearly (as a step function, a power function, a sine wave, or in some combination of these) over a certain limited period, and this non-linear variation is repeated in random fashion throughout its life, then:

$$P = \left( \frac{(P_1)^{3.33} + (P_2)^{3.33} + \dots + (P_n)^{3.33}}{T_1 + T_2 \dots T_n} \right)^{0.3}$$

Where  $P_1, P_2 \dots P_n$  represent loads acting during selected time intervals  $t_1, t_2, \dots t_n$ .

(c) If both speed and load vary, and each change in load is accompanied by a corresponding change in speed, then:

$$P = \left( \left[ (P_1)^{3.33} \times \frac{n_1}{33 \ 1/3} \times \frac{q_1}{100} \right] + \left[ (P_2)^{3.33} \times \frac{n_2}{33 \ 1/3} \times \frac{q_2}{100} \right] + \dots + \left[ (P_n)^{3.33} \times \frac{n_n}{33 \ 1/3} \times \frac{q_n}{100} \right] \right)^{0.3}$$

Where  $P_1, P_2 \dots P_n$  represent loads acting at speeds  $n_1, n_2 \dots n_n$ ; and  $q_1, q_2 \dots q_n$  represent percentage of time that  $P_1$  is acting at  $n_1, P_2$  is acting at  $n_2 \dots P_n$  is acting at  $n_n$ .



### HIGH STEADY LOADS AND SHOCK LOADS

Bearing basic dynamic capacity and basic static capacity are determined through a consideration of entirely different factors. The prime consideration for dynamic capacity is the magnitude of the stressed volume of metal and the probability that it will endure a given number of loading cycles. For static capacity, the prime consideration is the influence of the elastic limit and rupture limit as manifested by the extent of the permanent deformations that occur. In view of the seemingly great difference in bases for consideration of dynamic and static capacities, it might be concluded that they bear no relation to one another. Such is not always the case when considering very high steady loads or shock loads present in a rotating bearing. The extent to which these loads approach (or exceed) the basic static capacity will determine the validity of the use of the life formula. More explicitly, when the following relationship exists, ordinary means may be used in determining bearing life.

$$\frac{C_o}{f_s P_o} \geq \left( \frac{C/P}{33 \frac{1}{3}} \right)^{0.30}$$

Where  $C_o$  = Bearing basic static capacity-lbs

$P_o$  = Value of the radial load or maximum shock load-lbs

$f_s$  = Safety factor for high radial or shock loads (dependent on duration of peak load and type of bearing service demanded throughout life of bearing in given application)

$f_s = 0.5$  for occasional high steady load but no shock

$f_s = 1.0$  for continuous high steady load but no shock

$f_s = 2.0$  for maximum shock loads and/or where very smooth subsequent bearing operation is required

$C, P$  = As previously defined

$n$  = Rotational speed - rpm

A warning note on use of the above relation: even when the solution indicates that conventional means may be used in estimating bearing life, such a fatigue life forecast becomes invalid where less-than-optimum lubrication permits shock loads to induce fretting wear (false brinelling).

### MISALIGNMENT AND ROLLER CROWNING

ABMA Standards state, in effect, that optimum basic dynamic capacity  $C$  values refer to roller bearing mountings so designed and executed that uniform load distribution over the active roller length is assured. It is further stated that, if misalignment is present, a reduction in the capacity value should be made before estimation of rating life.

There are two basic types of bearing misalignment which commonly occur, defined as: (a) location misalignment, and (b) deflection misalignment. A brief explanation of these two types will serve to determine which capacity reduction factor should be used when misalignment exists in a given application. Location misalignment implies misalignment in a plane at right angles to the direction of the load. The type is associated with a skewing of the rollers on the roller track with a resultant distortion of the contact area. Location misalignment may arise as a consequence of two bearing supports, often a great distance apart, being out of line. Though very undesirable, this type of misalignment is not as serious as deflection misalignment, and does not result in a large bearing capacity reduction.

Deflection misalignment implies misalignment in the same plane as the direction of the load. This type is associated with a tendency toward "digging-in" of the roller ends on the roller tracks, with resultant high stresses at these points. With straight, non-crowned, cylindrical rollers this condition is much more exaggerated than in designs incorporating crowned cylindrical rollers, as shown in the figure to the right. All standard radial roller bearings incorporate accurately ground crowned rollers carefully blended at the crown junctions.

Deflection misalignment is encountered when moderate to heavy external radial loads exist on small diameter shafts and/or bearing supports are remote from the point of load application. It may also be encountered due to inaccuracies in machining of the shaft or housing. (See Mounting Practice.)

ROLLWAY laboratory tests, together with field experience and investigations into the theory of stress concentration on bearings subjected to misalignment, have shown the effect on bearing life of the above two basic types of misalignment. Life reductions directly relate to the type and degree of misalignment as a result of the high stress concentrations over a reduced portion of the total roller length.

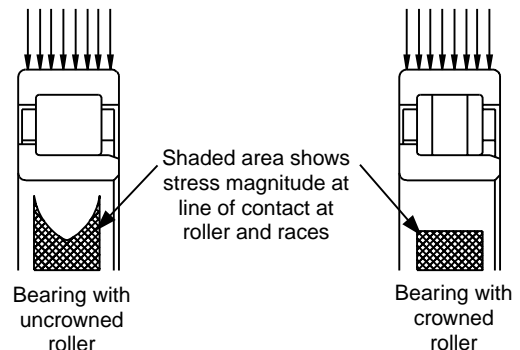



#### HIGH TEMPERATURE OPERATION

Bearing applications involving elevated temperatures preclude the use of standard bearing materials if full capacity is to be realized. In general, the temperature range is divided as follows:

- a. 250°F to 400°F
- b. 400°F to 800°F
- c. Over 800°F

Applications in range (a) can be adequately handled by alloy steels, such as SAE 52100 or carburized SAE 8620, suitably hardened and stabilized for the range of operating temperature. Little or no reduction in basic capacity should be expected. For range (b), high alloy tool steels (M-50) are used with substantially reduced basic capacity. In addition, protective environments become imperative to reduce oxidation and deterioration of the elements. For range (c), materials such as ceramics are required, however, design experience in this range is limited.

Dimensional stability must be considered in high temperature operation; generally it is not possible to stabilize the material completely; thus, small dimensional changes must be expected in extended service.

Retainer material selection for elevated temperature service is critical; adequate strength, differential thermal expansion coefficients, and temperature gradients (both steady-state and transient modes) must be considered in each design. The foregoing is especially true when land-riding retainers are required.

#### UNMOUNTED INTERNAL RADIAL CLEARANCE...

Unmounted internal radial clearance may be determined by two methods:

- a. Dimensionally from the geometry of the bearing
- b. By an inspection gaging procedure prescribed in the ABMA Standards handbook

Dimensionally, internal radial clearance is equal to the bore of the outer race minus the sum of the inner race OD and two roller diameters.

The gauging procedure specifies that one of the bearing races be fixed horizontally on a flat plate. A specified radial load is then applied to the unsupported race, alternately, in diametrically opposing directions. The internal radial clearance is the total displacement of the unsupported race.

The sole reason for manufacturing bearings with differing internal radial clearance is to give the designer a means to achieve predetermined clearance in the mounted revolving bearing. In determining this final running clearance it is necessary to take into consideration, in addition to the effects of shaft, housing interference fits and surface finish, the desire to meet one or more of the following conditions:

- a. Optimum load distribution through the rollers to result in maximum life
- b. Minimum bearing operating temperature
- c. Minimum bearing torque
- d. Minimum bearing noise level

The group classification of unmounted radial internal clearance should be specified only after a complete analysis of the resultant clearance of the mounted and operating bearing. The commonly available unmounted internal clearances of ROLLWAY bearings are shown in the tables on pages 74 & 75.

#### RESULTANT INTERNAL RADIAL CLEARANCE WITH BEARING MOUNTED AND IN OPERATION

The resultant bearing internal radial clearance after mounting and with the bearing in operation will differ from the unmounted clearance due to:

- a. The press fit between the shaft and inner race and/or a press fit between the housing and outer race, each resulting in an internal clearance reduction.
- b. An increase in the temperature of the inner race over that of the outer race, which will result in a reduction of internal clearance. Conversely, an increase in temperature of the outer race over that of the inner race may result in increased internal clearance.



The formula for the resultant internal clearance of the bearing after mounting and in operation is:

$$S_r = [S_0 - (S_1 \pm S_2 - S_3 \pm S_x)] \geq 0$$

Where:

$S_r$  = Resultant clearance - .0001 in.

$S_0$  = Initial (unmounted) clearance

$S_1$  = Clearance reduction due to interference fits

$S_2$  = Clearance reduction, or increase, due to race temperature differential

$S_3$  = Clearance increase due to load

$S_x$  = Clearance reduction, or increase, due to high rotational speed or any other effects

Determination of terms  $S_1$  through  $S_x$  is described in the following paragraphs.

### CLEARANCE REDUCTION DUE TO FIT

The clearance reduction due to fit is the sum of the effective inner race expansion, a, and the effective outer race contraction, b, under given press fit conditions (Shaft and Housing Fits).

$$S_1 = a + b \text{ (.0001")}$$

Where a & b are as follows:

a = expansion of the inner race is estimated; (interference fit) X .75

b = contraction of the outer race is estimated; (interference fit) X .85

And assumes the application has

- a. solid shaft
- b. rigid housing

In the case of a hollow shaft, and/or flexible housing, ROLLWAY Engineering should be consulted for resultant fits.

### CHANGE IN CLEARANCE DUE TO OTHER EFFECTS

Operating conditions normally will not be so unusual that other clearance effects ( $S_x$ ) must be considered. However, unusual cases do occur. It is suggested that the ROLLWAY Engineering Department be consulted when conditions may exist which warrant consideration of clearance changes ( $S_x$ ) that are not covered by terms  $S_1$ ,  $S_2$ , and  $S_3$ .



**Clearance Codes**  
**Used On Bearings With Tru-Rol & Max Numbering Systems**

Bearing Bore Dia. (Millimeter)		003		005		006 - Standard		007		009	
Over	Up to & include										
0	15	0.0003	0.0011	0.0009	0.0017	0.0010	0.0018	0.0011	0.0019	-	-
16	17	0.0004	0.0012	0.0009	0.0017	0.0010	0.0018	0.0012	0.0020	-	-
18	20	0.0005	0.0013	0.0010	0.0018	0.0012	0.0020	0.0014	0.0022	-	-
21	25	0.0005	0.0015	0.0011	0.0021	0.0013	0.0023	0.0015	0.0025	0.0024	0.0034
26	30	0.0006	0.0016	0.0013	0.0023	0.0015	0.0025	0.0017	0.0027	0.0027	0.0037
31	35	0.0007	0.0017	0.0015	0.0025	0.0017	0.0027	0.0019	0.0029	0.0030	0.0040
36	40	0.0008	0.0018	0.0016	0.0026	0.0018	0.0028	0.0020	0.0030	0.0032	0.0042
41	45	0.0008	0.0020	0.0017	0.0029	0.0020	0.0032	0.0022	0.0034	0.0036	0.0048
46	50	0.0009	0.0021	0.0017	0.0029	0.0020	0.0032	0.0023	0.0035	0.0036	0.0048
51	55	0.0010	0.0022	0.0019	0.0031	0.0022	0.0034	0.0025	0.0037	0.0039	0.0051
56	60	0.0011	0.0023	0.0022	0.0034	0.0025	0.0037	0.0028	0.0040	0.0044	0.0056
61	64	0.0012	0.0024	0.0023	0.0035	0.0025	0.0037	0.0029	0.0041	0.0046	0.0058
65	70	0.0012	0.0026	0.0024	0.0038	0.0027	0.0041	0.0030	0.0044	0.0048	0.0062
71	75	0.0013	0.0027	0.0026	0.0040	0.0030	0.0044	0.0033	0.0047	0.0052	0.0066
76	80	0.0014	0.0028	0.0026	0.0040	0.0030	0.0044	0.0034	0.0048	0.0052	0.0066
81	85	0.0014	0.0030	0.0028	0.0044	0.0032	0.0048	0.0036	0.0052	0.0056	0.0072
86	90	0.0014	0.0030	0.0028	0.0044	0.0032	0.0048	0.0036	0.0052	0.0056	0.0072
91	95	0.0016	0.0032	0.0030	0.0046	0.0034	0.0050	0.0038	0.0054	0.0059	0.0075
96	100	0.0016	0.0032	0.0031	0.0047	0.0035	0.0051	0.0039	0.0055	0.0061	0.0077
101	105	0.0017	0.0035	0.0032	0.0050	0.0037	0.0055	0.0041	0.0059	0.0064	0.0082
106	110	0.0017	0.0035	0.0033	0.0051	0.0038	0.0056	0.0043	0.0061	0.0066	0.0084
111	120	0.0019	0.0037	0.0036	0.0054	0.0041	0.0059	0.0046	0.0064	0.0071	0.0089
121	130	0.0020	0.0040	0.0039	0.0059	0.0044	0.0064	0.0049	0.0069	0.0076	0.0096
131	140	0.0022	0.0042	0.0042	0.0062	0.0048	0.0068	0.0054	0.0074	0.0083	0.0103
141	150	0.0023	0.0045	0.0045	0.0067	0.0051	0.0073	0.0057	0.0079	0.0088	0.0110
151	160	0.0025	0.0047	0.0048	0.0070	0.0054	0.0076	0.0060	0.0082	0.0093	0.0115
161	170	0.0027	0.0049	0.0050	0.0072	0.0057	0.0079	0.0064	0.0086	0.0097	0.0119
171	180	0.0028	0.0052	0.0053	0.0077	0.0060	0.0084	0.0067	0.0091	0.0130	0.0127
181	190	0.0030	0.0054	0.0056	0.0080	0.0063	0.0087	0.0072	0.0096	0.0110	0.0134
191	200	0.0032	0.0058	0.0059	0.0085	0.0067	0.0093	0.0075	0.0101	0.0115	0.0141
201	220	0.0035	0.0061	0.0063	0.0089	0.0072	0.0098	0.0080	0.0106	-	-
221	240	0.0038	0.0066	0.0070	0.0098	0.0078	0.0106	0.0087	0.0115	-	-
241	260	0.0042	0.0070	0.0076	0.0104	0.0085	0.0113	0.0096	0.0124	-	-
261	280	0.0045	0.0075	0.0080	0.0110	0.0090	0.0120	0.0101	0.0131	-	-
281	300	0.0049	0.0079	0.0085	0.0115	0.0097	0.0127	0.0109	0.0139	-	-
301	320	0.0053	0.0083	0.0093	0.0123	0.0105	0.0135	0.0117	0.0147	-	-



**Clearance Codes**  
**Used On Bearings With ISO Numbering Systems**

Bearing Bore Dia. (Millimeter)		C2		C0		C3		C4		C5	
Over	Up to & include										
0	10	0.0000	0.0012	0.0004	0.0016	0.0010	0.0022	0.0014	0.0026	0.0022	0.0033
11	18	0.0000	0.0012	0.0004	0.0016	0.0010	0.0022	0.0014	0.0026	0.0022	0.0033
19	24	0.0000	0.0012	0.0004	0.0016	0.0010	0.0022	0.0014	0.0026	0.0022	0.0033
25	30	0.0000	0.0012	0.0040	0.0018	0.0012	0.0026	0.0016	0.0028	0.0024	0.0037
31	40	0.0000	0.0014	0.0060	0.0020	0.0014	0.0028	0.0018	0.0032	0.0028	0.0041
41	50	0.0002	0.0016	0.0080	0.0022	0.0016	0.0030	0.0022	0.0035	0.0033	0.0047
51	65	0.0002	0.0018	0.0080	0.0026	0.0018	0.0035	0.0026	0.0041	0.0039	0.0055
66	80	0.0002	0.0022	0.0010	0.0030	0.0022	0.0041	0.0030	0.0049	0.0045	0.0065
81	100	0.0004	0.0024	0.0012	0.0032	0.0026	0.0045	0.0035	0.0055	0.0057	0.0077
101	120	0.0004	0.0026	0.0014	0.0035	0.0032	0.0053	0.0041	0.0063	0.0065	0.0087
121	140	0.0004	0.0030	0.0016	0.0041	0.0035	0.0061	0.0045	0.0071	0.0073	0.0098
141	160	0.0006	0.0032	0.0020	0.0045	0.0039	0.0065	0.0051	0.0077	0.0083	0.0108
161	180	0.0008	0.0034	0.0024	0.0049	0.0043	0.0069	0.0059	0.0085	0.0093	0.0118
181	200	0.0010	0.0037	0.0026	0.0053	0.0049	0.0077	0.0065	0.0092	0.0102	0.0123
201	225	0.0012	0.0041	0.0030	0.0059	0.0055	0.0085	0.0071	0.0100	0.0104	0.0144
226	250	0.0016	0.0045	0.0035	0.0065	0.0061	0.0090	0.0081	0.0110	0.0126	0.0156
251	280	0.0018	0.0049	0.0039	0.0071	0.0069	0.0100	0.0090	0.0122	0.0140	0.0171
281	315	0.0020	0.0052	0.0043	0.0077	0.0077	0.0110	0.0100	0.0134	0.0157	0.0191
316	355	0.0022	0.0057	0.0049	0.0085	0.0085	0.0120	0.0110	0.0146	0.0173	0.0209
356	400	0.0026	0.0063	0.0055	0.0093	0.0096	0.0134	0.0126	0.0163	0.0197	0.0234
401	450	0.0028	0.0075	0.0061	0.0108	0.0106	0.0153	0.0140	0.0179	0.0219	0.0266
451	500	0.0033	0.0081	0.0071	0.0118	0.0118	0.0165	0.0155	0.0202	0.0244	0.0291



## ***Radial Bearing Mounting Practice***

### **GENERAL MOUNTING PRECAUTIONS...**

Mounting the bearing has important effects on performance, durability, and reliability. Proper tools, fixtures, and techniques are a must for roller bearing applications, and it is the responsibility of the design engineer to provide for this in his design, advisory notes, mounting instructions, and service manuals. Nicks, dents, scores, scratches, corrosion staining, and dirt must be avoided if reliability, long life, and smooth running are to be expected of roller bearings.

### **BEARING FITS...**

The slipping or creeping of a bearing race on a rotating shaft or in a rotating housing, occurs when the fit is loose. Such slipping or creeping action can result in rapid wear of both the shaft and bearing races when the surfaces are dry and heavily loaded. To prevent this, the bearing is customarily mounted with a press fit on the rotating race and a push fit on the stationary race with the tightness or looseness dependent upon the service intended. Where shock or vibratory loads are to be encountered, fits should be made tighter than for ordinary service.

The assembly of a bearing on a shaft is best done by expanding the inner race by heating. This should be done in clean oil or in a temperature-controlled furnace at a temperature of between 200°F and 250°F as overheating will reduce the hardness of the races.

### **MOUNTING FOR PRECISION AND QUIET RUNNING APPLICATIONS...**

In applications of roller bearings where smoothness of operation is important, special precautions must be taken to eliminate those conditions which serve to initiate radial and axial motions. Accompanying these motions are forces that can excite bearing system excursions in resonance with shaft or housing components over a range of frequencies from well below shaft speed to as much as 100 times above it. The more sensitive the configuration, the greater the need for precision in the bearing and mounting. Among the important elements to be controlled are shaft, race, and housing roundness, squareness of faces, diameters, and shoulders. Though not readily appreciated, grinding chatter, lobular out-of-roundness, waviness, and any localized deviation from an average or mean diameter (even as a consequence of flat spots as small as .0005 in.) can cause significant operating roughness.

To detect the afore mentioned deficiencies and ensure the selection of good components, three-point electronic indicator inspection must be made. For ultra-precise or quiet applications, components are often checked on a continuous recording instrument capable of measuring to within a few millionths of an inch. Though this may seem extreme, it has been found that shaft deformities will be reflected through the bearings inner races. Similarly, tight-fit outer races pick up significant deviations in housings. Special attention is required both in housing design and in assembly of the bearing to shaft and housing. Housing response to axial excursions forced by bearing wobble resulting from out-of-square mounting has been found to be a major source of noise and howl in rotating equipment. Stiffer housings and careful alignment of bearing races make significant improvements in applications where noise or vibrations have been found to be objectionable.

### **SQUARENESS AND ALIGNMENT...**

In addition to the limits for roundness, squareness of end faces and shoulders must be closely controlled. Tolerances of .0001 in. full indicator reading per inch of diameter are normally required for shoulders, in addition to appropriately selected limits for fillet eccentricities. The latter must also fall within specified limits for radii tolerances to prevent interference with bearing race fillets, which results in cocking of the race. Reference should be made to the bearing dimension tables in Section 4, which list the corner radius for each bearing. Shoulders must also be of sufficient height to ensure proper support for the races.

### **SOFT METAL AND RESILIENT HOUSINGS...**

In applications where bearing housings are made of soft materials (aluminum, magnesium, light sheet metal, etc.) or those which lose their fit because of different thermal expansion, outer race mounting must be approached cautiously. First, determine the possible consequences of race loosening and turning. The type of loading must also be considered to determine its effect on race loosening. The force exerted by the rotating elements on the outer race can initiate a precession which will aggravate the race loosening problem through wear, pounding, and abrasion.

Since the pressing force is usually greater than the friction forces in effect between the outer race and housing, no foolproof method can be recommended for securing outer races in housings which deform significantly under load or after appreciable service wear. The surest solution is to press the race into a housing of sufficient stiffness with the heaviest fit consistent with the bearing operating clearances. Often, inserts or liners of cast iron or steel are used to maintain the desired fit and increase useful life of both bearing and housing.



#### SHAFT FITS

##### Inner Race Stationary, Outer Race Rotate

DESCRIPTION	EXAMPLE	BORE SIZE	FIT CODE
Inner race must be easily displaced	wheel	all	g6
Inner race need not be displaced	pulley, sheaves	all	h6

##### Inner Race Rotates, Outer Race Stationary

DESCRIPTION	EXAMPLE	BORE SIZE	FIT CODE
Light and variable loads (up to 7% of dynamic)	machine tools pumps	<40	j6
		40-140	k6
		140-200	m6
Normal to heavy loads	electric motors pumps gearboxes transmissions	<40	k5
		40-100	m5
		100-140	m6
		140-200	n6
		200-400	p6
Very heavy loads or shock loads	traction motors shaker screens	400-660	r6
		50-140	n6
		140-400	p6
		400-660	r6

#### HOUSING FITS

##### Inner Race Stationary, Outer Race Rotate

DESCRIPTION	EXAMPLE	BORE SIZE	FIT CODE
Heavy loads and thin walled housing	support wheel	all	P7
Normal and heavy loads	pulley, sheaves	all	N7
Light and variable loads	conveyor roller	all	M7

##### Direction of Load Indeterminate

DESCRIPTION	EXAMPLE	BORE SIZE	FIT CODE
Heavy shock loads	traction motors shaker screens	all	M7
Heavy and normal loads	electric motors pumps	all	K7
Normal and light loads	same as above	all	J7

##### Outer Race Stationary

DESCRIPTION	EXAMPLE	BORE SIZE	FIT CODE
Very heavy loads or shock loads	rail vehicles	all	J7
All loads	general applications	all	H7
Normal and light loads	line shafting	all	G7
Heat supplied through shaft	dryer cylinders	all	G7
High degree of accuracy	spindle	>250	P6
		125-250	N6
		<125	M6



#### Standard Shaft Fits

#### Resultant Fit By Fit Code And Bearing Bore Diameter (Inches)

BORE mm		g6	h6	j5	j6	k5	k6	m5	m6	n6	p6	r6
0	30	-0.0004	-0.0001	0.0002	0.0003	0.0005	0.0006	-	-	-	-	-
31	50	-0.0005	-0.0001	0.0003	0.0004	0.0006	0.0007	0.0009	-	-	-	-
51	80	-0.0005	-0.0001	0.0003	0.0004	0.0007	0.0008	0.0010	0.0011	0.0015	-	-
81	120	-0.0005	-0.0001	0.0003	0.0005	0.0008	0.0010	0.0012	0.0014	0.0018	0.0023	-
121	180	-0.0006	0.0000	0.0005	0.0006	0.0010	0.0011	0.0015	0.0016	0.0021	0.0027	-
181	240	-0.0006	0.0000	0.0005	0.0007	0.0012	0.0014	0.0017	0.0019	0.0024	0.0032	-
241	300	-0.0006	0.0000	0.0005	0.0007	0.0014	0.0015	0.0020	0.0021	0.0027	0.0036	-
301	320	-0.0006	0.0000	0.0005	0.0008	0.0015	0.0017	0.0021	0.0023	0.0030	0.0040	-
321	400	-0.0006	0.0001	0.0006	0.0008	0.0015	0.0017	0.0021	0.0023	0.0031	0.0040	-
401	500	-0.0007	0.0001	0.0007	0.0010	0.0016	0.0019	0.0023	0.0026	0.0035	0.0045	0.0067
501	622	-0.0008	0.0002	0.0007	0.0011	0.0018	0.0021	0.0026	0.0029	0.0036	0.0048	0.0076
623	660	-0.0014	0.0006	0.0013	0.0015	0.0024	0.0026	0.0033	0.0036	0.0044	0.0057	0.0079

#### Standard Housing Fits

#### Resultant Fit By Fit Code And Bearing Outside Diameter (Inches)

OD mm		G7	H6	H7	J7	K7	M6	M7	N6	N7	P6	P7
0	47	0.0011	0.0006	0.0007	0.0003	0.0000	-0.0003	-0.0003	-0.0006	-0.0006	-0.0010	-0.0010
48	80	0.0013	0.0006	0.0009	0.0004	0.0000	-0.0003	-0.0003	-0.0007	-0.0007	-0.0012	-0.0012
81	120	0.0015	0.0008	0.0010	0.0005	0.0000	-0.0003	-0.0004	-0.0008	-0.0008	-0.0013	-0.0013
121	150	0.0017	0.0009	0.0012	0.0006	0.0001	-0.0004	-0.0004	-0.0009	-0.0009	-0.0016	-0.0016
151	180	0.0019	0.0010	0.0013	0.0007	0.0002	-0.0003	-0.0003	-0.0008	-0.0008	-0.0014	-0.0014
181	250	0.0021	0.0012	0.0015	0.0009	0.0002	-0.0003	-0.0003	-0.0009	-0.0009	-0.0016	-0.0016
251	310	0.0024	0.0013	0.0017	0.0011	0.0003	-0.0003	-0.0003	-0.0009	-0.0009	-0.0018	-0.0018
311	400	0.0027	0.0015	0.0019	0.0012	0.0004	-0.0003	-0.0003	-0.0009	-0.0009	-0.0019	-0.0019
401	500	0.0030	0.0017	0.0022	0.0014	0.0004	-0.0003	-0.0004	-0.0010	-0.0010	-0.0021	-0.0021
501	622	0.0033	0.0019	0.0024	0.0015	0.0005	-0.0004	-0.0004	-0.0011	-0.0011	-0.0023	-0.0023
623	787	0.0040	0.0025	0.0030	0.0021	0.0010	0.0000	0.0000	-0.0008	-0.0008	-0.0022	-0.0022
788	960	0.0047	0.0030	0.0037	0.0027	0.0014	0.0003	0.0004	-0.0006	-0.0006	-0.0020	-0.0020

## SHAFT AND HOUSING DESIGN CONSIDERATIONS

For proper bearing operation, four basic considerations should be given to the design of shafts and housings. The shaft and housing should be designed to:

1. Prevent rotation of the race which is rotating relative to the load and prevent rotational creep in the stationary race.
2. Axially retain separable bearing races.
3. Incorporate means of transmitting thrust loads from the shaft to the housing.
4. Facilitate ease of mounting and removal.

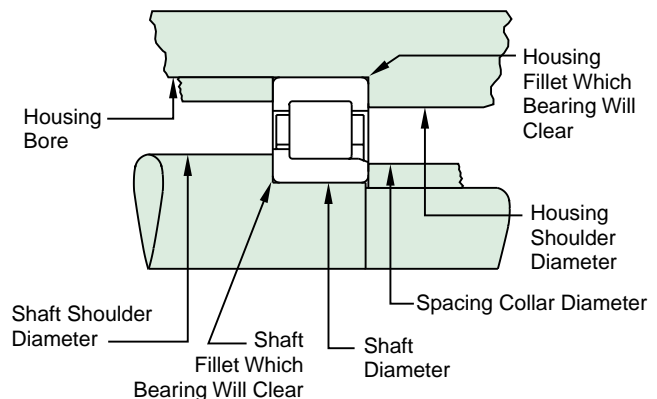





#### ***Thrust Bearing Mounting Practice***

When considering mounting and installation data there are three major areas of concern: shaft and housing fits, shaft and housing shoulders and shaft and housing tolerancing.

#### **SHAFT AND HOUSING FITS...**

The shaft and housing sizes and size tolerances are specified in the thrust bearing section, Pages 80 and 81.

There exists the possibility of a slight press fit due to the acceptable tolerances of the bearing bore and outside diameters. Under no circumstances should a press fit exceeding the limits shown be used with these plates, as any expansion or contraction in the plates due to fit could result in a misalignment in the plates and subsequent shorter bearing life.

#### **SHAFT AND HOUSING CLEARANCES...**

The tapered thrust bearing (TTHD style) plates are manufactured with the same ID and OD on both plates. Applications for these bearings must be designed with ample clearance between the OD of the shaft plate and the housing and between the ID of the housing plate and the shaft. Typically .030 inch is provided.

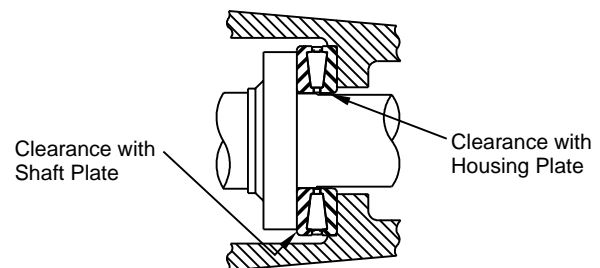

#### **PLATE BACKING AND SHAFT SHOULDERS...**

As a general rule the minimum shaft shoulder and maximum housing shoulder should be as follows:

- Shaft shoulder - at a minimum equal to the outside diameter of the shaft plate.
- Housing shoulder - maximum diameter must not exceed the inside diameter of the housing plate.
- For Tapered Thrust Bearings ROLLWAY Engineering must be consulted for shaft and housing shoulders.
- ROLLWAY Engineering must be consulted for shaft and housing shoulders that exceed the above rule.

#### **TOLERANCING...**

The shaft and housing squareness should be as follows:

- Equal to 0.0005 inch per inch of diameter. Example: 4" dia shaft should be square to the shaft shoulder within (4 X 0.0005) 0.002 inches



#### CYLINDRICAL THRUST

Bearing Bore Diameter		Shaft Diameter Deviation from Bore Diameter (-)	
over	incl	high	low
0.0000	1.1250	0.0005	0.0015
1.1250	1.3125	0.0006	0.0016
1.3125	1.5000	0.0007	0.0017
1.5000	1.6875	0.0008	0.0018
1.6875	1.8750	0.0009	0.0019
1.8750	2.1250	0.0010	0.0020
2.1250	2.5000	0.0011	0.0021
2.5000	3.0000	0.0012	0.0022
3.0000	3.5000	0.0013	0.0023
3.5000	7.0000	0.0015	0.0025
7.0000	9.0000	0.0015	0.0030
9.0000	12.0000	0.0018	0.0033
12.0000	15.0000	0.0020	0.0035
15.0000	19.0000	0.0020	0.0040
19.0000	23.0000	0.0025	0.0045
23.0000	30.0000	0.0030	0.0055

Bearing Outside Diameter		Housing Diameter Deviation from Outside Diameter (+)	
over	incl	high	low
2.0000	2.3750	0.0015	0.0005
2.3750	3.2500	0.0017	0.0007
3.2500	3.6875	0.0019	0.0009
3.6875	4.0000	0.0021	0.0011
4.0000	4.5312	0.0028	0.0013
4.5312	10.0000	0.0030	0.0015
10.0000	18.0000	0.0040	0.0020
18.0000	22.0000	0.0050	0.0025
22.0000	26.0000	0.0055	0.0025
26.0000	28.0000	0.0060	0.0030
28.0000	34.0000	0.0070	0.0030
34.0000	38.0000	0.0080	0.0035
38.0000	44.0000	0.0090	0.0040



#### TAPERED THRUST

Bearing Bore Diameter		Spring Loaded Shaft Diameter Deviation from Bore Diameter (-)	
over	incl	high	low
0.0000	6.8750	0.0000	0.0010
6.8750	7.9999	0.0000	0.0010
7.9999	12.0000	0.0000	0.0015
12.0000	24.0000	0.0000	0.0020
24.0000	36.0000	0.0000	0.0025
36.0000	48.0000	0.0000	0.0030

Bearing Outside Diameter		Housing Diameter Deviation from Outside Diameter (+)	
over	incl	high	low
0.0000	10.5000	0.0025	0.001
10.5000	13.0000	0.003	0.001
13.0000	20.0000	0.004	0.002
20.0000	25.0000	0.0045	0.002
25.0000	30.0000	0.006	0.003
30.0000	35.0000	0.007	0.003

#### CRANE HOOK

Bearing	Hook Shank	Housing Diameter
CT-11	WCT-11	None specified
CT-16	WCT-16	
CT-17	WCT-17	
CT-19	WCT-19	
CT-20C	WCT-20C	
CT-20-B	WCT-20-B	
CT-23	WCT-23	
CT-24-A	WCT-24-A	
CT-27-A	WCT-27-A	
CT-27-C	WCT-27-C	
CT-27-B	WCT-27-B	
CT-28-A	WCT-28-A	
CT-34-A	WCT-34-A	
CT-35-A	WCT-35-A	
CT-38-A	WCT-38-A	
CT-39-A	WCT-39-A	
CT-44-A	WCT-44-A	
CT-45-A	WCT-45-A	
CT-49-A	WCT-49-A	
CT-54	WCT-54	
CT-756-201	WCT-756	



**Standard Metric Journal Roller Bearings  
Shaft And Housing Fits**

Shaft Dimensions				
Bearing Bore	Shaft Diameter - inches		Resultant Fit	
Nominal - mm	Max	Min	Tight	Tight
25	0.9850	0.9845	0.0002	0.0011
30	1.1819	1.1814	0.0003	0.0012
35	1.3788	1.3783	0.0003	0.0013
40	1.5758	1.5752	0.0004	0.0015
45	1.7728	1.7722	0.0005	0.0016
50	1.9697	1.9691	0.0006	0.0017
55	2.1666	2.1660	0.0006	0.0018
60	2.3635	2.3628	0.0006	0.0019
65	2.5605	2.5598	0.0007	0.0020
70	2.7574	2.7566	0.0007	0.0021
75	2.9544	2.9536	0.0008	0.0022
80	3.1512	3.1504	0.0008	0.0022
85	3.3482	3.3474	0.0009	0.0025
90	3.5450	3.5442	0.0009	0.0025
95	3.7420	3.7412	0.0010	0.0026
100	3.9389	3.9380	0.0010	0.0027
110	4.3328	4.3318	0.0011	0.0029
120	4.7266	4.7256	0.0012	0.0030
130	5.1204	5.1194	0.0013	0.0033
140	5.5142	5.5131	0.0013	0.0034
150	5.9080	5.9069	0.0014	0.0035
160	6.3019	6.3007	0.0015	0.0037
170	6.6957	6.6944	0.0015	0.0038
180	7.0895	7.0882	0.0016	0.0039
200	7.8770	7.8757	0.0017	0.0042
220	8.6644	8.6631	0.0017	0.0042

Housing Dimensions				
Bearing OD.	Housing Bore - Inches		Resultant Fit	
Nominal - mm	Max	Min	Tight	Tight
62	2.4419	2.4409	0.0010	0.0005
72	2.8357	2.8346	0.0011	0.0005
80	3.1508	3.1496	0.0012	0.0005
85	3.3478	3.3465	0.0013	0.0006
90	3.5446	3.5432	0.0013	0.0007
100	3.9384	3.9369	0.0014	0.0007
110	4.3322	4.3306	0.0015	0.0007
120	4.7260	4.7243	0.0016	0.0007
125	4.9229	4.9212	0.0016	0.0009
130	5.1197	5.1179	0.0016	0.0010
140	5.5135	5.5116	0.0017	0.0010
150	5.9073	5.9053	0.0018	0.0010
160	6.3011	6.2990	0.0019	0.0012
170	6.6948	6.6926	0.0019	0.0013
180	7.0886	7.0863	0.0020	0.0013
190	7.4824	7.4800	0.0021	0.0015
200	7.8762	7.8737	0.0022	0.0015
215	8.4669	8.4643	0.0023	0.0015
225	8.8606	8.8580	0.0023	0.0015
230	9.0574	9.0547	0.0023	0.0016
240	9.4512	9.4484	0.0024	0.0016
250	9.8450	9.8421	0.0025	0.0016
260	10.2388	10.2358	0.0026	0.0018
270	10.6326	10.6295	0.0027	0.0018
280	11.0263	11.0231	0.0027	0.0019
290	11.4201	11.4168	0.0028	0.0019
300	11.8138	11.8105	0.0028	0.0019
310	12.2076	12.2042	0.0029	0.0019
320	12.6013	12.5978	0.0029	0.0022
340	13.3888	13.3852	0.0030	0.0022
380	14.9637	14.9599	0.0031	0.0023

## LUBRICATION

Proper lubrication is essential to achieving desired bearing life. Each roller bearing application creates individually different requirements for adequate lubrication. To assist in selecting the lubricant and lubrication method, the following information is furnished as a guide. Generally, the assistance of a qualified engineering representative from a lubricant company should be enlisted. If specific recommendations are required for a particular application, consult the ROLLWAY engineering department.

### Lubricants are used:

- a. To reduce friction
- b. To prevent wear
- c. To prevent adhesion
- d. To aid in distributing the load
- e. To cool the moving elements
- f. To prevent corrosion

Adequate lubrication is necessary in the rolling-contact areas, on contacts between roller and retainer, on contacts between the roller end and flange and on other areas where sliding takes place. Lubrication is required to prevent galling, adhesion, wear, corrosion, scuffing, welding and pitting. Of primary importance is adequate lubrication of the roller (Hertzian) contacts to avoid reduction of bearing fatigue life. These heavily loaded areas between the rollers and raceways impose the most critical requirement on the lubricant and its properties.

Lubricants of too low an initial viscosity or those too sensitive to temperature changes may induce shallow spalls under conditions of high slip (as in misalignment) and may induce plastic flow of the contacting surfaces.

Lubricants are often limited by their ability:

- a. To replenish themselves
- b. To dissipate frictional heat
- c. To resist high environmental temperatures
- d. To remain stable under operating conditions

One important purpose of a lubricant is to prevent corrosion of the bearing surfaces engaged in rolling (Hertzian) contact. Many applications involve environments which allow water to accumulate in the bearing cavity. Whether from direct intake or condensation, moisture is detrimental and a lubricant must be selected to disperse the water or to prevent its attack on the metal since corrosion drastically reduces bearing life. Applications involving heavy loads and high operating temperatures also require careful approaches. Here extreme pressure (EP) lubricants should be used. High shaft speeds generally dictate lubricant selection based on the need for cooling, the suppression of churning or aeration of conventional lubricant and, most important of all, the inherent speed limitations of certain bearing types.

## LUBRICATION RECOMMENDATIONS...

It has been ROLLWAY Bearings policy to not recommend any specific lubricant for a given application but instead to recommend the required viscosity of the lubricant at operating temperature to provide adequate lubrication. Below are the recommended viscosities by product type:

<b>Product</b>	<b>Viscosity @ Operating Temperature</b>
Cylindrical Radial Roller Bearing	110 SSU
Cylindrical Thrust Bearing	125 SSU
Tapered Thrust Bearing	160 SSU
Tandem Thrust Bearing	160 SSU

## OIL LUBRICATION

Oil lubrication is normally used when speeds and temperatures are high or when it is desired to have a central oil supply for the machine as a whole. Cooled oil is sometimes circulated through the bearing to carry off excess heat resulting from high speeds heavy loads. Oil for anti-friction bearing lubrication should be well refined with high film strength, good resistance to oxidation and good corrosion protection. Anti-oxidation additives are generally acceptable but are of significance only at higher operating temperatures (over 185°F). Anti-corrosion additives are always desirable.

### 1.Lubricating Oils

Lubrication oils are marketed with additives developed for particular applications. It is advisable to consult the engineering representative of a reputable lubricant company on the proper selection for the conditions under consideration.



#### 1. Lubricating Oils (Continued)

The following are the most common types of additives:

- a. Oxidation inhibitor.
- b. Viscosity index improver.
- c. Defoaming agent.
- d. Rust inhibitor.
- e. Boundary lubrication improver.
- f. Detergent-dispersant.
- g. Pour-point depressant.

Some additives are not stable over the entire temperature and shear-rate ranges considered acceptable for straight mineral oils. Additive oils must be carefully monitored to ensure that they are not continued in service after their principal capabilities have been diminished or depleted. The action of the detergent-dispersant additives (used to reduce and control degradation products which would otherwise deposit on the operating of parts and oil cavity walls) may cause an accelerated deposition rate of foaming when they have been degenerated by temperature or contamination. The ingestion of water by condensation or leakage can cause markedly harmful effects. Viscosity index improvers serve to modify oils by reducing their change in viscosity over the operating temperature range. These materials may be used to improve a heavy or light oil. However, the original stock may revert to its natural state when the additive has depleted or been degraded by exposure to high temperatures or shear rates normally encountered in the load zones of bearings. In heavy duty installations, it is advisable to select a heavier or a more highly refined oil.

#### 2. Applications of Lubricating Oils

Many oil selections result in excessive operating temperatures due to high initial viscosity which raises friction. Generally, the lightest weight oil capable of carrying the maximum load should be used. In many mechanisms, the thicker fluid may increase friction losses sufficiently to lower the operating viscosity into the range provided by an initially lighter fluid. Improved cooling, accomplished by increasing the oil flow, can improve the fluid properties in the load zone.

#### 3. Oil Lubrication Systems

The lubrication system must provide each roller bearing with a uniform, continuous supply of clean oil and must satisfy the cooling requirement of the bearing. Oil lubrication systems are also designed to meet the following needs:

- a. Adaptability to function over the range of variables encountered in the operating regime.
- b. Reliability in a given operating environment and over the length of the normal maintenance periods.
- c. Maintainability.
- d. Over-all ability to meet the requirements of the system application.
- e. Relative cost when compared to the cost of machine or application.

The table below provides a list of commonly used lubrication systems and shows some of the significant features that must be considered in their design and selection for roller bearing applications.

Lubrication System	Initial Cost	Required Maintenance	Oil Flow	Cooling	Reliability	Sensitivity to Environmental Changes	Sealing Requirements
Manual	Low	High	Variable and dependent on worker for continuity	Minimal and variable	Poor	Highly adaptable	Not Significant
Drip Feed	Low	Contingent upon type of service and location of lubrication points	May vary with time	Low	Average	May be affected by temperature variations	Not Significant
Splash	Dependent on design	Negligible	Dependent upon maintenance of oil level in housing	Fair	High	Sensitive to low temperature May accumulate moisture due to condensation	Generally critical
Wick Feed	Low to Medium	Medium	Uniform, filtered, continuous	Negligible	High, if wick is maintained	Sensitive to low temperature	Not Significant
Pressure Circulating System	High	Medium	Controlled and continuous Adding filtration ensures clean oil supply	Excellent, can include heat exchanger	High	May accumulate moisture due to condensation	Important
Air-Oil Mist	High	Medium	Positive, automatic delivery of regulated oil quantity, free of contamination	Excellent	High	Sensitive to low temperature	Important

## GREASE LUBRICATION

Rolling contact bearings are often grease lubricated because grease is easier to retain in the housing over a longer period than oil and grease acts, to some extent, as a seal against the entry of dirt and other contaminants into the bearing.

In bearing applications, care must be taken not to overfill the cavity. The bearing should have a practical quantity of grease worked into it, with the rolling elements thoroughly coated and the retainer covered, but the housing should be no more than 75% full; with soft grease, no more than 50%. Excessive packing is indicated by overheating, churning, aerating, and eventual purging with final failure due to insufficient lubrication. In grease lubrication, never add more than is actually required.

Grease is usually not a suitable lubricant for Dn factors over 300,000 (bore in mm times speed in rpm). For temperatures over 210°F, the grease renewal periods should be very short.

Normally, grease should not be allowed to remain in a bearing if any of the following are found at inspection:

- a. The oil content is less than 50%.
- b. The corrosion protection properties are diminished.
- c. The acidity has changed.
- d. Liquid or solid contaminants are present.
- e. Liquification has started.
- f. Significant color change.

### **1. Lubricating Greases**

Greases are applied where fluid lubricants cannot be used because of the difficulty of retention, re-lubrication or because of the danger of churning. Greases are usually made by using soap or inorganic compounds to thicken petroleum or synthetic oils. The thickener is used to immobilize the oil, acting as a reservoir to release the oil at a slow rate. Though the thickener may have lubrication properties itself, the oil bleeding from the bulk of the grease is felt to be the determining factor. When the oil has depleted to approximately 50% of the total weight of the grease, the lubricating ability of the grease becomes doubtful.

### **2. Grease Consistency Classifications**

Greases are divided into grades by the NLGI (National Lubricating Grease Institute), ranging from 0, the softest, up through 6, the stiffest. The grade is determined by testing a penetrometer, measuring the depth of penetration of a specific weighted cone. Most greases have thixotropic properties (they soften with working) and, as such, must be considered for their worked properties rather than in the "as-received" condition. Conversely, many greases are found to stiffen when exposed to high shear rates in automatic grease dispensing equipment.

To limit shock loads and settling, grease-lubricated bearing housings should have dividers to keep the bulk of the grease in place. Grease lubrication depends on a relatively small amount of mobile lubricant (the oil bled out of the bulk) to replenish that thrown out of the bearing during operation. If the space between the bulk of the grease and the bearing is too large, then a long delay (determined by the grease bleed rate and its temperature) will be encountered before lubricant in the bearing is resupplied. This delay may effect bearing life.

Grease is normally applied with the material in the cavity contacting the bearing in the lower quadrant for bearings mounted on horizontal shafts. The initial action of the bearing when rotated is to purge itself of excess grease and to clear a path for bleed oil to enter the bearing. Therefore, greases selected are often of grade 2 or 3 consistency, referred to as the "channeling" variety.



### **3. Types of Grease**

Most commonly used greases utilize lithium soaps or sodiums and some may use the modified-clay thickeners. In all-around use, the lithium soap greases are employed for moderate temperature applications (up to 225°F) while a number of sodium soap greases perform well up to 285°F.

Major lubricant suppliers offer different formulations for these temperature ranges, making it advisable for the user to consult with the suppliers' engineering representatives. Also, the volatility of the oil used affects the useful life of the bulk grease applied to the bearing cavity and the viscosity of the oil affects the load-carrying capacity of the grease. Both must be considered in the selection.

For use in roller bearings, grease must have the following properties:

- a. Freedom from chemically or mechanically active ingredients, such as disassociated metals or oxides, and similar mineral or solid contaminants.
- b. A very slow change in consistency, such as thickening, separation of oil, evaporation or hardening during operation.
- c. A drop-point and melting point considerably higher than the operating temperatures.

### **4. Temperature Effects on Grease Life**

Operating temperatures must be carefully considered and controlled to ensure adequate grease and bearing life. Grease is subject to the general rule that, above a critical temperature, each 15°F of rise in temperature cuts the oxidation life of the lubricant in half.

### **5. Relubricating with Grease**

Where bearings are inaccessible but sealed, grease may be replenished providing a re-lubrication method has been properly developed. A basic procedure similar to the following is recommended.

- a. Use the identical original grease.
- b. Clean the fittings to prevent contamination of the cavity.
- c. Remove the cap and the drain plug.
- d. Clean out the drain.
- e. Weigh the grease gun.
- f. Apply the specified quantity or fill until grease comes out the drain.
- g. Weigh the grease gun again to verify amount applied.
- h. Operate with the drain open long enough to permit purging and ensure safe temperature rise.

Samples of the purged material should be inspected to check for lubricant oxidation and for foreign material (that could be contamination) and for bearing particles indicative of incipient failure.

Cleaning and re-packing may be done by hand in designs where the bearing is accessible. When replacing the grease, it should be forced between the rollers with fingers, dismantling the bearing, if convenient. The available space inside the bearing should be filled completely and the bearing should then be turned slowly by hand. Any grease thrown out should be wiped off. The space on each side of the bearing in the housing should not be more than 50% filled. Too much grease will result in considerable churning, high bearing temperatures and the possibility of early failure.



To estimate conservative grease renewal periods, the equation below, may be used. Final determination of the grease renewal period for a specific application must be made experimentally. The assistance of a technical representative from a reliable lubricant company should be sought.

$$I_{\text{lub}} = \frac{1.67 y_1 y_2 y_3 y_4 \times 10^7}{n \times B^{0.5}}$$

Where  $I_{\text{lub}}$  = Lubrication interval-hours

$y_1$  = 1.5 for bearing with one piece broached, two piece drilled or segmented retainer  
 1.0 for bearing with stamped steel retainer  
 0.8 for full roller type

$y_2$  = 1.5 for bearing with bore < 50mm  
 1.0 for bore 50mm to < 200mm  
 0.5 for bore > 200mm

$y_3$  = 1.5 for operating temperature < 130°F  
 1.0 for 130°F <= operating temperature <= 200°F  
 0.5 for operating temperature > 200°F

$y_4$  = 1.5 for operating speed < 500 rpm  
 1.0 for 500 rpm <= operating speed < 3600rpm  
 0.5 for operating speed > 3600 rpm

$n$  = Bearing speed - rpm

$B$  = Bearing bore - mm

The following factors must be considered in determining the grease lubrication interval:

- a. The formula is recommended as a general guide only.
- b. The formula is valid up to the following maximum speeds:
  - 1" shaft diameter - 8600 rpm
  - 2" shaft diameter - 4300 rpm
  - 3" shaft diameter - 2850 rpm
  - 4" shaft diameter - 2150 rpm
  - 5" shaft diameter - 1725 rpm
  - 6" shaft diameter - 1425 rpm
- c. For lubrication interval where speeds are in excess of those indicated in (b), consult the ROLLWAY engineering department.

Normally, commercial grease should not be allowed to remain in a bearing for longer than 48 months. If the service is very light and temperatures are low, 60 months is the maximum, regardless of the number of hours of operation during that period, since oxidation and separation of the oil from the soap continue whether or not the bearing is in operation.

All sales are made on our STANDARD TERMS AND CONDITIONS OF SALE in effect at the time a customer's order is accepted. The current Terms and Conditions are set forth below:

## STANDARD TERMS AND CONDITIONS OF SALE (March 19, 1999)

These Terms and Conditions, the attendant quotation or acknowledgment and all documents incorporated by specific reference therein, will be the complete and exclusive statement of the terms of the agreement governing the sale of goods ("Goods") by **Emerson Power Transmission Corporation** and its divisions and subsidiaries ("Seller") to Customer ("Buyer"). Buyer's acceptance of the Goods will manifest Buyer's assent to these Terms and Conditions. If these Terms and Conditions differ in any way from the terms and conditions of Buyer's order, or other documentation, this document will be construed as a counteroffer and will not be deemed an acceptance of Buyer's terms and conditions which conflict herewith.

1. **PRICES:** Unless otherwise specified in writing by Seller, Seller's price for the goods shall remain in effect for thirty (30) days after the date of Seller's quotation or acknowledgment of Buyer's order for the Goods, whichever occurs first, provided an unconditional, complete authorization for the immediate shipment of the Goods is received and accepted by Seller within such time period. If such authorization is not received by Seller within such thirty (30) day period, Seller shall have the right to change the price for the Good to Seller's price for the Goods at the time of shipment.

2. **TAXES:** Any tax or governmental charge or increase in same hereafter becoming effective increasing the cost to Seller of producing, selling or delivering the Goods or of procuring material used therein, and any tax now in effect or increase in same payable by the Seller because of the manufacture, sale or delivery of the Goods, may at Seller's option, be added to the price.

3. **TERMS OF PAYMENT:** Subject to the approval of Seller's Credit Department, terms are net thirty (30) days from date of Seller's invoice in U.S. currency. If any payment owed to Seller is not paid when due, it shall bear interest, at a rate to be determined by Seller, which shall not exceed the maximum rate permitted by law, from the date on which it is due until it is paid. Seller shall have the right, among other remedies, either to terminate the Agreement or to suspend further performance under this and/or other agreements with Buyer in the event Buyer fails to make any payment when due. Buyer shall be liable for all expenses, including attorneys' fees, relating to the collection of past due amounts.

4. **SHIPMENT AND DELIVERY:** Shipments are made F.O.B. Seller's shipping point. Any claims for shortages or damages suffered in transit shall be submitted by the Buyer directly to the carrier. While Seller will use all reasonable commercial efforts to maintain the delivery date acknowledged or quoted by Seller, all shipping dates are approximate. Seller reserves the right to make partial shipments and to segregate "specials" and made-to-order Goods from normal stock Goods. Seller shall not be bound to tender delivery of any Goods for which Buyer has not provided shipping instructions.

5. **QUANTITY:** Buyer agrees to accept overruns of up to ten percent (10%) of the order on "made-to-order" Goods, including parts. Any such additional items shall be priced at the price per item charged for the specific quantity ordered.

6. **LIMITED WARRANTY:** Subject to the limitations of Section 7, Seller warrants that the Goods will be free from defects in material and workmanship under normal use, service and maintenance for a period of one year (unless otherwise specified by Seller in writing) from the date of shipment of the Goods by Seller. **THIS IS THE SOLE AND EXCLUSIVE WARRANTY GIVEN BY SELLER WITH RESPECT TO THE GOODS AND IS IN LIEU OF AND EXCLUDES ALL OTHER WARRANTIES, EXPRESS OR IMPLIED, ARISING BY OPERATION OF LAW OR OTHERWISE, INCLUDING WITHOUT LIMITATION, MERCHANTABILITY OR FITNESS FOR A PARTICULAR PURPOSE WHETHER OR NOT THE PURPOSE OR USE HAS BEEN DISCLOSED TO SELLER IN SPECIFICATIONS, DRAWINGS OR OTHERWISE, AND WHETHER OR NOT SELLER'S PRODUCTS ARE SPECIFICALLY DESIGNED AND/OR MANUFACTURED BY SELLER FOR BUYER'S USE OR PURPOSE.**

This warranty does not extend to any losses or damages due to misuse, accident, abuse, neglect, normal wear and tear, unauthorized modification or alteration, use beyond rated capacity, or improper installation, maintenance or application. To the extent that Buyer or its agents has supplied specifications, information, representation of operating conditions or other data to Seller in the selection or design of the Goods and the preparation of Seller's quotation, and in the event that actual operating conditions or other conditions differ from those represented by Buyer, any warranties or other provisions contained herein which are affected by such conditions shall be null and void. If within thirty (30) days after Buyer's discovery of any warranty defects within the warranty period, Buyer notifies Seller thereof in writing, Seller shall, at its option, repair or replace F.O.B. point of manufacture, or refund the purchase price for, that portion of the goods found by Seller to be defective. Failure by Buyer to give such written notice within the applicable time period shall be deemed an absolute and unconditional waiver of Buyer's claim for such defects. Goods repaired or replaced during the warranty period shall be covered by the foregoing warranty for the remainder of the original warranty period or ninety (90) days, whichever is longer. Buyer assumes all other responsibility for any loss, damage, or injury to persons or property arising out of, connected with, or resulting from the use of Goods, either alone or in combination with other products/components.

**SECTIONS 6 AND 7 APPLY TO ANY ENTITY OR PERSON WHO MAY BUY, ACQUIRE OR USE SELLER'S GOODS, INCLUDING ANY ENTITY OR PERSON WHO BUYS THE GOODS FROM SELLER'S DISTRIBUTOR AND SUCH ENTITY OR PERSON SHALL BE BOUND BY THE LIMITATIONS THEREIN.**

7. **LIMITATION OF REMEDY AND LIABILITY: THE SOLE AND EXCLUSIVE REMEDY FOR BREACH OF ANY WARRANTY HEREUNDER (OTHER THAN THE WARRANTY PROVIDED UNDER SECTION 13) SHALL BE LIMITED TO REPAIR, REPLACEMENT OR REFUND OF THE PURCHASE PRICE UNDER SECTION 6. SELLER SHALL NOT BE LIABLE FOR DAMAGES CAUSED BY DELAY IN PERFORMANCE AND IN NO EVENT, REGARDLESS OF THE FORM OF THE CLAIM OR CAUSE OF ACTION (WHETHER BASED IN CONTRACT, INFRINGEMENT, NEGLIGENCE, STRICT LIABILITY, OTHER TORT OR OTHERWISE), SHALL SELLER'S LIABILITY TO BUYER AND/OR ITS CUSTOMERS EXCEED THE PRICE TO BUYER OF THE SPECIFIC GOODS PROVIDED BY SELLER GIVING RISE TO THE CLAIM OR CAUSE OF ACTION. BUYER AGREES THAT IN NO EVENT SHALL SELLER'S LIABILITY TO BUYER AND/OR ITS CUSTOMERS EXTEND TO INCLUDE INCIDENTAL, CONSEQUENTIAL OR PUNITIVE DAMAGES. THE TERM "CONSEQUENTIAL DAMAGES" SHALL INCLUDE, BUT NOT BE LIMITED TO, LOSS OF**

### **ANTICIPATED PROFITS, LOSS OF USE, LOSS OF REVENUE, COST OF CAPITAL AND DAMAGE OR LOSS OF OTHER PROPERTY OR EQUIPMENT.**

It is expressly understood that any technical advice furnished by Seller with respect to the use of the Goods is given without charge, and Seller assumes no obligation or liability for the advice given, or results obtained, all such advice being given and accepted at Buyer's risk.

**GOODS AND/OR SERVICES SOLD HEREUNDER ARE NOT FOR USE IN ANY NUCLEAR AND RELATED APPLICATIONS.** Buyer accepts goods and/or services with the foregoing understanding, agrees to communicate the same in writing to any subsequent purchaser or users and to defend, indemnify and hold harmless Seller from any claims, losses, suits, judgments and damages, including incidental and consequential damages, arising from such use, whether the cause of action be based in tort, contract or otherwise, including allegations that the Seller's liability is based on negligence or strict liability.

8. **EXCUSE OF PERFORMANCE:** Seller shall not be liable for delays in performance or for non-performance due to acts of God, acts of Buyer, war, riot, fire, flood, other severe weather, sabotage, or epidemics; strikes or labor disturbances; governmental requests, restrictions, laws, regulations, orders or actions; unavailability of or delays in transportation; default of suppliers; or unforeseen circumstances or any events or causes beyond Seller's reasonable control. Deliveries may be suspended for an appropriate period of time as a result of the foregoing. If Seller determines that its ability to supply the total demand for the Goods, or to obtain material used directly or indirectly in the manufacture of the Goods, is hindered, limited or made impracticable due to causes addressed in this Section 8, Seller may allocate its available supply of the Goods or such material (without obligation to acquire other supplies of any such Goods or material) among itself and its purchasers on such basis as Seller determines to be equitable without liability for any failure of performance which may result therefrom. Deliveries suspended or not made by reason of this section may be canceled by Seller upon notice to Buyer without liability, but the balance of the agreement shall otherwise remain unaffacted.

9. **CANCELLATION:** The Buyer may cancel orders only upon written notice and upon payment to Seller of cancellation charges which include, among other things, all costs and expenses incurred and commitments made by the Seller and a reasonable profit thereon.

10. **CHANGES:** Buyer may request changes or additions to the Goods consistent with Seller's specifications and criteria. In the event such changes or additions are accepted by Seller, Seller may revise the price and delivery schedule. Seller reserves the right to change designs and specifications for the Goods without prior notice to Buyer, except with respect to Goods being made-to-order for Buyer.

11. **TOOLING:** Tool, die, and pattern charges, if any, are in addition to the price of the Goods and are due and payable upon completion of the tooling. All such tools, dies and patterns shall be and remain the property of Seller. Charges for tools, dies, and patterns do not convey to Buyer, title, ownership interests in, or rights to possession or removal, nor prevent their use by Seller for other purchasers, except as otherwise expressly provided by Seller and Buyer in writing with reference to this provision.

12. **ASSIGNMENT:** Buyer shall not assign its rights or delegate its duties hereunder or any interest therein or any rights hereunder without the prior written consent of the Seller, and any such assignment, without such consent, shall be void.

13. **PATENTS AND COPYRIGHTS:** Subject to Section 7, Seller warrants that the Goods sold, except as are made specifically for Buyer according to Buyer's specifications, do not infringe any valid U.S. patent or copyright in existence as of the date of delivery. This warranty is given upon the condition that Buyer promptly notify Seller of any claim or suit involving Buyer in which such infringement is alleged, and, that Buyer cooperate fully with Seller and permit Seller to control completely the defense or compromise of any such allegation of infringement. Seller's warranty as to use only applies to infringements arising solely out of the inherent operation (i) of such Goods, or (ii) of any combination of Goods in a system designed by Seller. In the event such Goods, singly or in combination, are held to infringe a U.S. patent or copyright in such suit, and the use of such Goods is enjoined, or in the case of a compromise by Seller, Seller shall have the right, at its option and expense, to procure for Buyer the right to continue using such Goods, or replace them with non-infringing Goods; or modify same to become non-infringing; or grant Buyer a credit for the depreciated value of such Goods and accept return of them.

14. **MISCELLANEOUS:** These terms and conditions set forth the entire understanding and agreement between Seller and Buyer, and supersede all other communications, negotiations and prior oral or written statements regarding the subject matter of these terms and conditions. No change, modification, rescission, discharge, abandonment, or waiver of these terms and conditions of Sale shall be binding upon the Seller unless made in writing and signed on its behalf by an officer of the Seller. No conditions, usage or trade, course of dealing or performance, understanding or agreement purporting to modify, vary, explain, or supplement these Terms and Conditions shall be binding unless hereafter made in writing and signed by the party to be bound, and no modification shall be affected by the acceptance of purchase orders or shipping instruction forms containing terms at variance with or in addition to those set forth herein. No waiver by Seller with respect to any breach or default or any right or remedy and no course of dealing, shall be deemed to constitute a continuing waiver of any other breach or default or of any other right or remedy, unless such waiver be expressed in writing and signed by the party to be bound. Seller is not responsible for typographical or clerical errors made in any quotation, orders or publications. All such errors are subject to correction. The validity, performance, and all other matters relating to the interpretation and effect of this contract shall be governed by the law of the state of New York.