

**BODINE**®

**ELECTRIC**

**COMPANY**

Catalog S-16

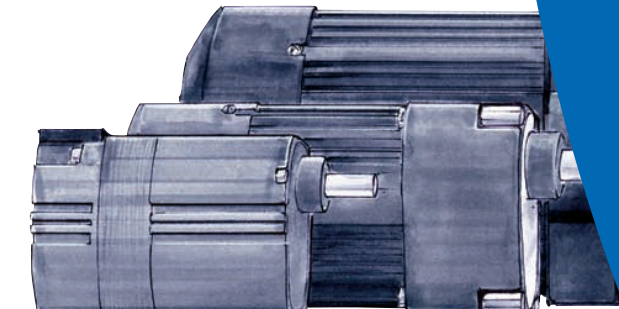
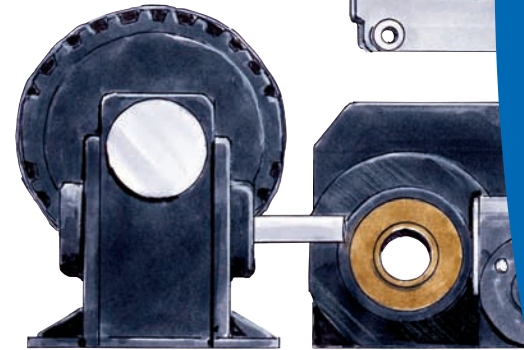
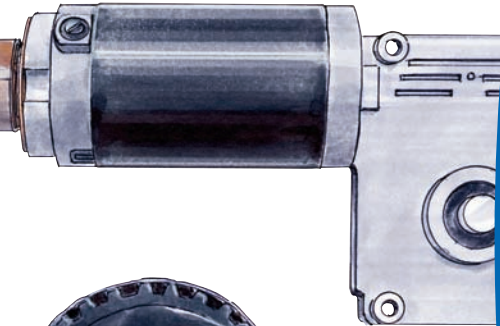
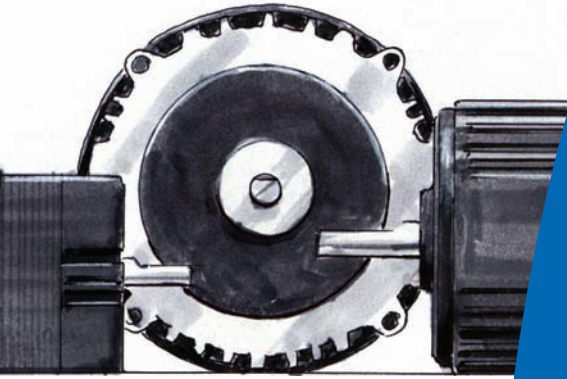
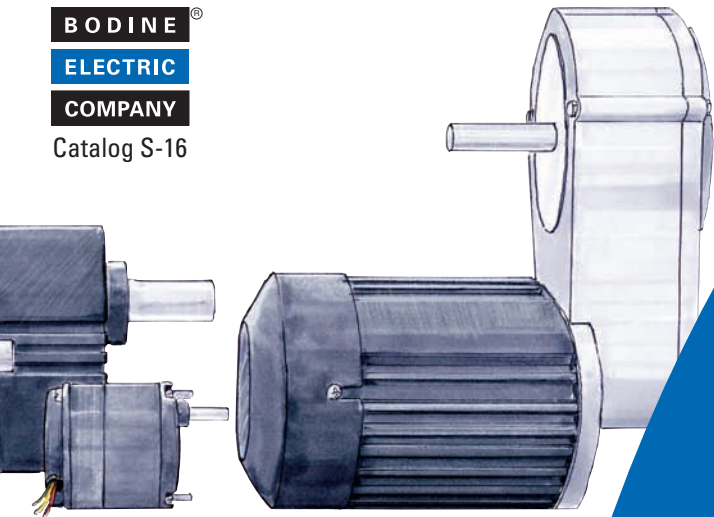

# ***BODINE***

*Electric Company*

*Small Motors | Gearmotors | Controls*

**1-800-7BODINE** [www.bodine-electric.com](http://www.bodine-electric.com)

## Table of Contents

● <b>What's New</b> .....	i
General Information.....	ii
President Message.....	iii
Zero Lead Time.....	iv
3D Models Online.....	v
Product Overview.....	vi
3RD Gearmotors.....	viii
Type "HG" Parallel Shaft Gearmotors.....	x
● <b>e-TORQ™ (BLDC), Servo Motors</b> .....	<b>4</b>
● <b>INTEGRAMotor™ (BLDC)</b> .....	<b>7</b>
● <b>Hollow Shaft Products</b> .....	<b>11</b>
● <b>Custom Solutions</b> .....	<b>20</b>
● <b>AC Products</b> .....	<b>23</b>
Pacesetter™ AC Inverter Duty Products.....	24
Technical Information.....	43
Torque Motors.....	44
Motors and Gearmotors.....	46
Accessories.....	62
Capacitors.....	63
Connection Diagrams.....	64
● <b>DC Products</b> .....	<b>65</b>
Technical Information.....	66
Motors, Gearmotors and Controls.....	67
Accessories.....	100
● <b>Brushless DC Products</b> .....	<b>103</b>
Technical Information.....	104
Electrical Connections.....	105
Motors, Gearmotors and Controls.....	106
Accessories.....	122
● <b>Model Number Index</b> .....	<b>123</b>
<b>Metric Information</b> .....	<b>127</b>
<b>Warranty</b> .....	<b>128</b>

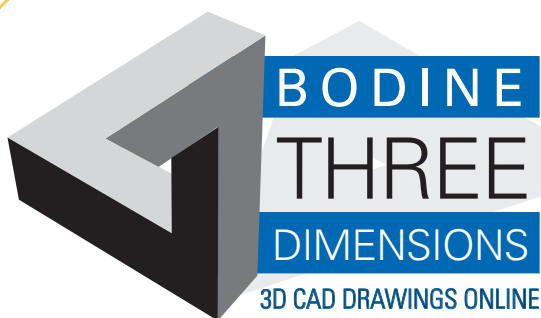

## Now Available Online

For more information, see Page v

Three dimensional CAD files of Bodine's motors, gearmotors and controls can now be instantly downloaded from ThomasNet.com and CADRegister. Engineers can now view, download and email three dimensional drawings for use in a wide range of CAD file formats.

## Ordering Information

### World-wide Distributor Network

Bodine products are sold through the industry's premier network of high-tech and power transmission distributors. Our extensive distributor network serves the United States, Canada, and targeted areas of Europe and Asia. To find the nearest distributor of Bodine products, call us at 1-800-7BODINE, or visit Bodine-Electric.com.

### Same Day Shipping

Bodine Electric has the industry's largest off-the-shelf offering of fractional horsepower motors, gearmotors and controls! Most are available for shipping the same day from any of our distributors, or our main warehouse.

### MotionPROs— at your service

When you have a question about how to choose and apply motion systems, look no further than the Bodine Electric MotionPRO. Backed by the most experienced engineering, application, testing and customer support group in the fractional horsepower motion field, Bodine MotionPROs are available to answer your questions or assist in your project. To find the nearest MotionPRO, call us at 1-800-7BODINE, or visit Bodine-Electric.com.

### Bodine-Electric.com is better than ever

Product locators, detailed specifications, complete operating instruction manuals, 2D and 3D CAD drawings are all available at the click of a mouse. Surf by to see the latest Bodine Electric product offerings, or visit our on-line Company Store to see what's being offered for sale this week.

### Call us at 1-800-7BODINE

Use this toll-free number to get more information about how to order products, determine the status of an order, and obtain general information. Outside the U.S., call us at **773-478-3515**.

## Contact Us

Phone..... 1-800-7BODINE

Fax..... (773) 478-3232

Mail..... Bodine Electric Company  
2500 West Bradley Place  
Chicago, IL 60618 U.S.A.

Email..... sales@bodine-electric.com

Visit us on-line and browse our several Web sites. There, you can find free technical product information, download the latest CAD drawings, or just request a copy of our latest literature. Get the answers you need right now!

Online..... Bodine-Electric.com  
Bodinegears.com

*There's a lot new at Bodine Electric. Whether it's totally new product lines, like the type HG and 3RD gearmotors, or extensions to existing product lines like the INTEGRAmotor, e-TORQ and hollow shaft right-angle gearmotors, Bodine Electric is always in motion.*



## INTEGRAmotor

See page 7

Our new **INTEGRAmotor™** Brushless DC products combine three Bodine strengths—motor design, gear manufacturing, and electronic control application—into one dynamite package that reduces wiring, panel space, assembly time, and cost. **Now models are available with digital (PWM) speed input.**



21 NEW BRUSHLESS MOTORS!

## e-TORQ

See page 4

Whether you call it detent torque, reluctance torque, or cogging, Bodine Electric's new e-TORQ brushless servomotors eliminate it. e-TORQ motors produce peak torques up to ten times rated torque, eliminating the need for gearboxes in many applications. And unlike some direct drive solutions that are limited by top speeds of several hundred rpm, e-TORQ offers a speed range from 1 to 6000+ rpm.



## Hollow Shaft Gearmotors

See page 11

**Now you can specify a hollow output shaft as an option on any right angle gearmotor.** With continuous output torques from 5.2 to 575 lb-in. and gear ratios from 5:1 to 3600:1, our hollow shaft right angle gearmotors offer output speeds from less than 1 rpm to over 500 rpm. Bodine offers a wide variety of mechanical details of the hollow bore from keyways to internal hexes or splines.



38 NEW GEARMOTORS!

## Type 3RD Gearmotors

See page viii

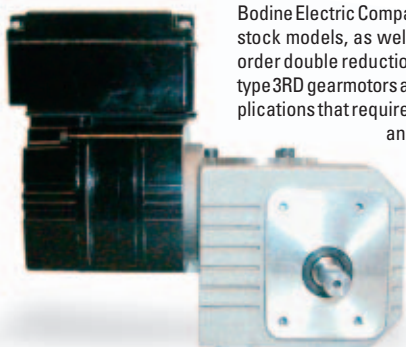

Bodine Electric Company now offers new stock models, as well as many built-to-order double reduction gearmotors. The type 3RD gearmotors are designed for applications that require very slow rotation and high torque.

30 NEW GEARMOTORS!

## Type HG Gearmotors

See page x

The HG gearhead provides flexible mounting and high torque in a small package. Typical applications include conveyor systems, food processing equipment, and factory automation.



24 NEW GEARMOTORS!

**New from Bodine**

# General Information

## How to Order

All stock items are available from Authorized Bodine Distributors. To order any stocked product just specify the model number. "N" model numbers require lead time and minimum quantities.

## Applications

Consistent performance, long life, and reliability are fundamental to Bodine designs. Since 1905 Bodine motors, gearmotors, and controls have been used in assembly equipment, conveyers, packaging equipment, copiers, lab instruments, photographic processors, medical and other scientific apparatus... wherever component size, weight, reliability and integrity are prime considerations.

If you need selection assistance, please contact your Representative or Distributor. To ensure proper selection and best service, please provide the following:

- Your application and ambient conditions
- Voltage and frequency
- Direction of rotation, reversing
- Maximum speed and speed range
- Starting torque and running load
- Duration of continuous run and rest periods
- Size, weight, and noise limitations
- Motor mounting position
- Life requirement
- Estimated annual requirements

For existing Bodine applications, please provide the Type and Serial No.—both on the nameplate.

## Safety and Installation Precautions

Bodine products are designed and manufactured to comply with applicable safety standards. Since even well-built apparatus can be installed or operated in a hazardous manner, it is important that safety considerations be observed by the user. With respect to the load and environment, the user must properly select, install, and use the apparatus.

It is the responsibility of the equipment manufacturer or the individual installing the apparatus to take diligent care in installing it. Local electrical and safety codes should be followed when installing the apparatus to reduce hazards to persons and property.

Bodine totally enclosed (IP-44) products are not explosion proof nor dust-ignition proof. Bodine does not offer products for locations which are exposed to flammable/explosive gas, vapor or dust. An approved explosion proof or dust-ignition proof product is recommended for hazardous locations.

For more safety information request Motor/Gearmotor Safety, Installation, Use and Maintenance Information PN 074 00045.

## Gearmotor Mounting Positions

The preferred mounting position for each gearmotor in this catalog is horizontal, as illustrated in their respective dimension diagrams. Gearmotor mountings other than shown are not recommended on some gearmotors due to (a) the possibility of gearhead lubricant leakage into the motor portion, (b) insufficient lubrication. By making the proper adjustments (normally done at the factory), mountings other than the preferred positions of gearmotors are possible.

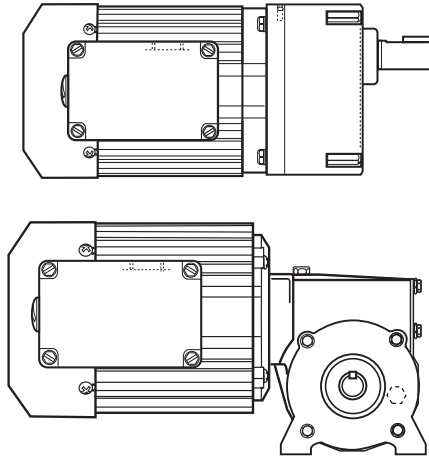

## Construction Recognition

Most Bodine products are "third party approved". The specific approvals for each product are shown on the appropriate pages.

Motors and gearmotors conform to U.L. standard 1004 and CSA standard C22.2 No. 100. They are contained in U.L. file number E47177 and CSA file number LR2797.

Electronic controls conform to U.L. standard 508 and CSA standard C22.2 No. 14. They are contained in U.L. file number E44529 and CSA file number LR26397.

Equipment for sale in Europe must meet the requirements of council Directive 72/23/EEC. The purpose of the EEC directive is to state minimum technical requirements common to all the member states within the European Union. These minimum technical requirements enhance safety levels both directly and

indirectly. Compliance with these specifications is indicated with a **CE** on the equipment.

Products in this catalog that show the CE mark on its dimensional page comply with the Machinery or Low Voltage Directives. The CE mark will be included on the motor rating nameplates. Depending on the application, the use of optional terminal boxes and terminal strips may be required. Drives, modules, or systems (including motors) supplied as part of a customer's machine are considered as components, and are not required to show the CE mark. It is the responsibility of the integrator or machine builder to gain acceptance of the entire machine.

Motors with U.S. and Canadian approval may carry the **UL** and **CSA** marks, or the **UL** mark alternatively.

## Bodine Handbook

Download the Bodine Handbook at [www.bodine-electric.com](http://www.bodine-electric.com) for the complete manual of fractional horsepower motors and gearmotors. The 244 page handbook is packed with valuable information including 25 pages of helpful articles, charts and a glossary of terms.



## Additional Product Information

For additional product information please visit our Web site.

© Copyright 2006. Catalog data subject to change without notice. Printed in U.S.A.

# A word from our President



I want to personally thank you for considering using Bodine products in your application. Should you decide to form a new relationship with us, or continue an existing one, we can be counted on to do two things well:

1. **Problem-solving**—We have the top design engineering team in the industry! They can solve your most demanding application challenges as well as design cost effective, high value, products.
2. **Quality/Craftsmanship**—We also have a manufacturing organization that does “all the right things” consistently. Once you’ve designed us in, you won’t have quality or delivery concerns going forward.

By paying attention to each small detail we create a superior product at a competitive price, ready to receive the Bodine label.

## Extensive Product Line

As you browse through this catalog or visit our website, [bodine-electric.com](http://bodine-electric.com), you’ll see that our product line is the most extensive in the fractional horsepower motor market. We have Brushless, A.C. and D.C. products ranging from 1/1600 HP up to about 1 HP, as well as matching electronic controls. This variety allows you to select exactly what you need with a minimum of com-

promises. We can also produce variations on any of our standard models or add functionality and features where needed. We have the capability to give you EXACTLY what you want at a very competitive price.

This large selection of standard products also makes it possible to turn samples around rapidly. We want to help you solve problems. Involve us early in the design process, and don’t hesitate to challenge us. That’s what Bodine Electric is all about!

## Family Owned for Over 100 Years

Bodine Electric celebrated its 100th anniversary in 2005. We plan to continue as a family-owned and operated organization. We enjoy our work, and because our name is on the product, we are passionate about the quality and value we offer to customers.

We continuously improve our organization: we achieve nearly perfect on-time delivery, and we continually reduce our lead times. New opportunities are addressed quickly and professionally. At Bodine Electric our goal is to not only build the best products, but also provide the best service.

## Environmentally Responsible

Bodine Electric cares about the environment and has taken the necessary action to insure that our products don’t have an adverse effect on it. Early in 2006, Bodine Electric started manufacturing many of our products in compliance with the European Directive 2002/95/EC on the Restriction of Hazardous Substances (RoHS). By the end of 2006, all but a few of the products in this catalog will be manufactured in compliance with the RoHS directive and will be marked as such.





# Zero Lead Time

It's Money In The Bank, Not Your Warehouse

We offer ready access from over 611 local distribution outlets, as well as Kanban, Safety-Stock and many other inventory management programs. They all ensure you pay only for what you use, when you use it. And if that isn't enough, we'll design a new delivery system for what you do need. Because at Bodine we not only believe in making motors that last, we think your budgets should too. Here are seven ways Bodine can help you achieve Zero Lead Time.

## Your Local Authorized Bodine Electric Distributor

The simplest way to achieve Zero Lead Time is to purchase stock products from your local Bodine Electric Company distributor. Simply visit [bodine-electric.com](http://bodine-electric.com) and enter your ZIP code in our Distributor Locator to view a detailed listing of your local Bodine distributors.

## [www.bodine-electric.com](http://www.bodine-electric.com)

If your motor and control requirements are for only one or two units at a time, it's good to know that the Bodine Electric warehouse stocks over 10,000 AC, DC and brushless DC electric motors, gearmotors and system matched motion controls. Most orders ship same day (if order entered before 1:00 p.m. CST) or within 24 hours. Orders are shipped securely via UPS with order tracking (next day service is available and you can even have shipping charged to your own UPS account). International orders ship via UPS Worldwide Express with order tracking. Additionally, you can also order accessories (mounting brackets, terminal boxes, encoders, etc.) as well as replacement parts (brushes, springs, brush caps, etc.) using [bodine-electric.com](http://bodine-electric.com). Of course, for the best volume pricing, contact your authorized Bodine distributor or Bodine MotionPRO sales engineer. You can find them by using the convenient locators on our website at [www.bodine-electric.com](http://www.bodine-electric.com).

## Blanket Order with Scheduled Releases

If your motor requirements are fairly regular and predictable, a blanket order with

scheduled release dates and quantities is the simplest way to eliminate lead time, while letting you benefit from the volume discounts available with such a purchase.



## Kanban

Quite simply, Kanban is the Japanese word for "signal". A big benefit of Kanban delivery systems is that they limit inventory build up. Therefore, you tie up less cash and space, you do less handling, you reduce work-in-process inventory, and also reduce your own lead times. Kanban systems can also reduce your reliance on those ever-elusive forecasts. Bodine Electric has many years experience working with customers on effective Kanban delivery systems that reduce lead time to merely shipping time and ensure customers never run out of product. Your Bodine MotionPRO can work with you to tailor a Kanban delivery agreement meeting your needs. A purchase order and a forecast of your expected usage will help us determine the proper bin sizes for your requirements so that as soon as you take a Kanban shipment we begin building more inventory here to meet your future needs.

## Safety Stock

This works best when the customer purchases a minimum of 200 units per year of the same model and has a minimum of eight inventory turns per year. In this arrangement, we agree to maintain a mutually agreed upon amount of "safety stock" specifically for your needs. All it requires is a commitment from the customer in the form of a Purchase Order or Letter of Intent agreeing to ultimately purchase the safety stock should the customer's needs or specifications change.

## Flexible Delivery Program

Also known as our "Rolling Horizon" program, this Zero Lead Time tool is based on a signed agreement and annual blanket order with firm releases scheduled throughout the year. The releases are automatically shipped unless the customer notifies us 30 days before the scheduled shipment date. A deferred shipment will then be scheduled to one month after the last date scheduled in the one-year period.

## Vendor Managed Inventory

This Zero Lead Time tool is a hybrid of KanBan, Safety Stock, and Flexible Delivery. It works best when your annual motor requirements are in the thousands of units. Your Bodine MotionPRO and our Supply Chain experts will work closely with you to combine your visibility/forecast knowledge with the best lot sizes for your operations to ensure you always have the proper inventory levels for your immediate needs.

# Instantly Download Bodine 3D Models and CAD Drawings



Three dimensional models of Bodine motors, gearmotors and controls can now be instantly downloaded from [www.Bodine-electric.com](http://www.Bodine-electric.com) in conjunction with [ThomasNet.com](http://ThomasNet.com) and [CADRegister.com](http://CADRegister.com). Engineers can now view, download and e-mail three dimensional drawings for use in a wide range of CAD file formats.

## Designing with Bodine has never been easier

To access the complete library of Bodine stock products online, simply go to [www.bodine-electric.com](http://www.bodine-electric.com) and click on the CAD link in the product listing menu. A second window will open, which will allow you to choose from a variety of formats, including 3D models.

### Three Ways to Access Files From ThomasNet.com

- **Direct Insert**—Engineers can simply insert the image of the drawing directly from the web browser into their 3D software package. Most commonly used CAD programs are supported, including AutoCAD, Inventor, Mechanical Desktop, ProENGINEER, Solid Edge, Solid Works, Catia, TopSolid, TurboCAD, Think3 Designer, and Rebarc.
- **Download the files**—Bodine product drawings may also be downloaded directly to your hard drive in a variety of formats, including STEP, DXF 3D, ACIS SAT, IGES, and VDA-F.
- **E-mail the files**—The files may also be e-mailed directly from our website.



Model Number	Speed (RPM)	Motor HP (1/2-1)	Rated Torque (lb-in)	Gear Ratio	Mounting	Accuracy Class	View
6140	15	1/12	180	171.4	130V	NO	view
6147	8	1/12	175	312.4	130V	NO	view
6148	600	1/8	8	3.8	130V	NO	view
6149	450	1/8	12	3.8	130V	NO	view
6180	200	1/8	21	4.4	130V	NO	view
6181	180	1/8	21	13.0	130V	NO	view
6182	123	1/8	44	20.8	130V	NO	view
6190	84	1/8	88	20.7	130V	NO	view
6191	57	1/8	96	42.9	130V	NO	view
6192	30	1/8	182	40.8	130V	NO	view
6194	20	1/8	355	97.5	130V	NO	view
6647	8	1/12	175	312.4	24V	NO	view
6652	123	1/8	44	20.8	24V	NO	view
6654	57	1/8	96	42.9	24V	NO	view
6656	20	1/8	182	97.5	24V	NO	view
6658	15	1/12	180	171.4	130V	YES	view
6657	8	1/12	175	312.4	130V	YES	view
6659	600	1/8	8	3.8	130V	YES	view
6659	450	1/8	12	3.8	130V	YES	view
6659	200	1/8	21	4.4	130V	YES	view
6661	180	1/8	21	13.0	130V	YES	view



To access our most up-to-date CAD drawings and 3D models, go to [www.bodine-electric.com](http://www.bodine-electric.com), and (1) click on a CAD link, then (2) choose "view 3D Model." From the ThomasNet.com window you may directly insert the file directly into a 3D software tool, download a file to your computer desktop, or e-mail it.



MADE IN U.S.A.

New  
e-TORQ™  
INTEGRAMotor™  
Hollow Shaft  
Custom  
Pacesetter™ Inverter Duty  
AC Induction  
Permanent Magnet DC  
Brushless DC  
Index

# Bodine Products At A Glance

After you have determined the Bodine product that best fits your needs, visit [www.bodine-electric.com](http://www.bodine-electric.com). There you will find the most up-to-date specifications, 2-D and 3-D CAD drawings and models, list prices and ordering information for all of the over 1,000 stock and standard products we offer.

## Motors Without Gearing

- For direct drive applications
- For high speed applications
- Ball bearings
- Totally enclosed construction
- Balanced rotors or armatures
- Models with NEMA mountings
- Models with metric mountings
- 126 models available

## Parallel Shaft Gearmotors

- High efficiency gearing
- Fits in places where right angle gearmotors don't
- Unvented gearhousings for multiple mounting positions
- Lubricated for life of gearmotor, without maintenance
- Up to five stages of gearing for very slow speeds
- Seals on input shaft and output shaft
- 484 models available

## AC Induction

- Available with most common AC winding types:
  - Pacemaker™, 3-phase, inverter duty models
  - Permanent split capacitor, 1-phase; (impedance protected and torque winding models available in most frame sizes)
  - Split-phase models, 1-phase with starting switch
- Totally enclosed construction; fan cooled and non-fan cooled models
- UL recognized, CSA certified, and with CE mark

**Horsepower**  
1/600-3/4

**Speed Ranges (rpm)**  
120-3,600

**Torque (oz-in.)**  
1.1-445

**Horsepower**  
1/2000-3/4

**Speed (rpm)**  
0.9-340

**Torque (lb-in.)**  
8.9-1,000



## Permanent Magnet DC

- Low cost
- 24, 90/130, and 180 volt models in stock
- Adjustable speed and high starting torque
- Linear speed/torque curve
- Totally enclosed construction
- Replaceable brushes
- Different voltage and speed ratings available
- Dynamic braking
- UL recognized, CSA certified, and with CE mark
- Models with accessory shaft for mounting a brake or encoder

**Horsepower**  
1/50-1/2

**Speed Ranges (rpm)**  
100-11,500

**Torque (oz-in.)**  
8-180

**Horsepower**  
1/29-1/2

**Speed (rpm)**  
5.6-660

**Torque (lb-in.)**  
3.3-700



## Brushless DC

- For detailed information about e-TORQ or the 24VDC, INTEGRAMotor products, please see pages 4-10
- 24VDC and 130VDC models in stock
- Ideal for continuous duty applications
- Adjustable speed and high starting torque
- Linear speed/torque curve
- Totally enclosed construction
- Zero Maintenance, longest life
- Dynamic braking
- 22B and 34B models UL recognized, and CSA certified
- Models with accessory shaft for mounting a brake or encoder
- 60° built-in commutation standard (120° available with OEM products)
- Optional built-in encoder for custom models

**Horsepower**  
1/16-2

**Speed Ranges (rpm)**  
100-10,000

**Torque (oz-in.)**  
20-151

**Horsepower**  
1/16-3/8

**Speed (rpm)**  
8-500

**Torque (lb-in.)**  
5.8-350

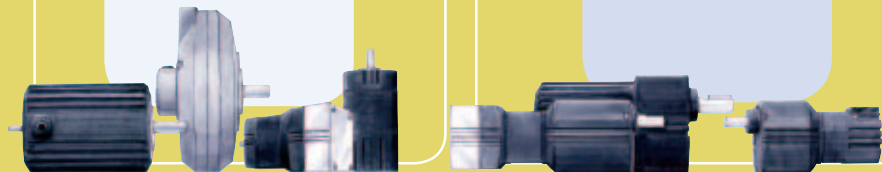



### Right angle gearmotors

- **Hollow shaft models available** in all right angle products
- Quiet worm gearing
- Worm gearing resists shock loads
- Many gear ratios are self-locking
- Fits in places where parallel shaft gearmotors don't
- Unvented gearhousing for multiple mounting positions
- Lubricated for life of gearmotor, without maintenance
- Seals on input shaft and output shaft
- 322 models available

### Matched Electronic Speed Controls

- Models for each motor type:
  - Permanent Magnet DC
  - Three-phase AC Induction (inverter-duty)
  - Brushless DC
- Models with NEMA enclosures
- Open chassis models
- 2 year warranty when purchased with Bodine motors
- 50 models available

#### Horsepower

1/17-3/4

#### Speed (rpm)

5.9-340 rpm

#### Torque (lb-in.)

8-380

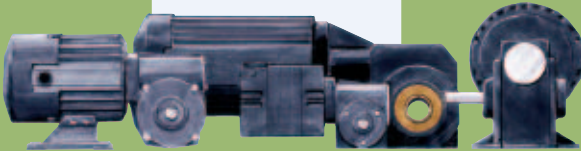

#### Horsepower

1/2-1

#### Voltage

supply: 115, 230, 115/230  
output: 0-230, 3Ø

#### Current (Amps)

2.4-4.0

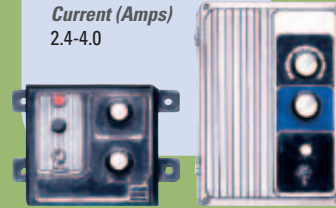

Page 23

#### Horsepower

1/29-1/2

#### Speed (rpm)

0.7-500

#### Torque (lb-in.)

5.2-380



#### Horsepower

1/17-7/16

#### Voltage

supply: 115, 115/230  
output: 0-90, 0-130, 0-180

#### Current (Amps)

0.50-5.0

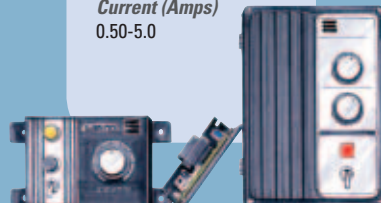

Page 65

#### Horsepower

1/8-3/8

#### Speed (rpm)

42-500

#### Torque (lb-in.)

11-109



#### Horsepower

1/6-3/8

#### Voltage

supply: 24VDC, 115VAC  
output: 0-24, 0-90, 0-130

#### Current (Amps)

3.0-22



Page 103

# Double-Reduction Gearmotor Provides High Torque At Low Speeds

Up to 148 lb-in. continuous

Bodine Electric Company now offers new stock models, as well as many built-to-order double reduction gearmotors. The type 3RD gearmotors are designed for applications that require very slow rotation and high torque. Typical applications include conveyor systems, food processing equipment, medical equipment and factory automation.

The type 3RD gearmotors are available with Bodine's 30R AC, 24A DC, and 22B brushless DC motors. The double-reduction design provides gear ratios from 200:1 up to 3600:1, allowing a relatively small motor to produce

up to 148 lb-in. torque. The gearheads are offered with outputs ranging from 0.4 to 12.5 rpm. The 3RD models are unvented with bronze and hardened steel worm gears for low maintenance and long life. The gearmotor is offered with a variety of built-to-order shaft options, including single, double or hollow shaft configurations. Hollow shaft units can be connected directly to the driven load, which saves space and eliminates unnecessary parts that are bulky and present alignment issues. The gearhousing was designed for maximum flexibility. These gearmotors can be face-mounted on the drive-shaft side, or can be mounted from the bottom.



## AC Induction Gearmotors

Speed (rpm)	Torque (lb-in.)	Motor (HP)	V	Frequency (Hz)	Ph	A (Amps)	Gear Ratio	Radial Load	Length XH (in.)	Wt. (Ref. lbs.)	Connection Diagram	Capacitor P/N	Product Type	Model Number <sup>1</sup>
<b>TYPE 30R-3RD (Permanent Split Capacitor, Non-Sync, Double Reduction, Right-Angle Gearmotors, TENV)</b>														
0.4	95	1/30	115	60	1	0.47	3600	160	8.16	9	074 10296	494 01015	30R2BECI-3RD	N8536
1.1	121	1/30	115	60	1	0.47	1400	160	8.16	9	074 10296	494 01015	30R2BECI-3RD	N8514
2.7	148	1/20	115	60	1	0.59	600	160	8.66	10.5	074 10296	494 01015	30R4BECI-3RD	N8506
5.3	101	1/20	115	60	1	0.59	300	160	8.66	10.5	074 10296	494 01015	30R4BECI-3RD	N8503
8.0	88	1/20	115	60	1	0.59	200	160	8.66	10.5	074 10296	494 01015	30R4BECI-3RD	N8502
<b>TYPE 30R-3RD (Inverter Duty, Three-Phase, Non-Sync, TENV; SOA<sup>2</sup> Frequency Range: 10-90 Hz) PACESETTER™</b>														
0.5	95	1/25	230	60	3	0.38	3600	160	8.16	9	074 10296	494 01015	30R2BEPP-3RD	N8036
1.2	121	1/25	230	60	3	0.38	1400	160	8.16	9	074 10296	494 01015	30R2BEPP-3RD	N8014
2.8	148	1/17	230	60	3	0.48	600	160	8.66	10.5	074 10296	494 01015	30R4BEPP-3RD	<b>8006</b>
5.7	146	1/17	230	60	3	0.48	300	160	8.66	10.5	074 10296	494 01015	30R4BEPP-3RD	N8003
8.5	141	1/17	230	60	3	0.48	200	160	8.66	10.5	074 10296	494 01015	30R4BEPP-3RD	N8002

## Permanent Magnet DC Gearmotors

Speed (rpm)	Torque (lb-in.)	A (Amps)		Peak Torque (lb-in.)	Motor HP	Form Factor	Gear Ratio	Radial Load	Length XH (in.)	Wt. (lbs.)	Product Type	Model No.	
		24V	130V									24V	130V
<b>TYPE 24A-3RD</b>													
0.7	95	1.8	—	—	1/25	1.0	3600	160	8.07	7.9	24A2BEPM-3RD	N4336	—
0.7	95	—	0.3	—	1/29	1.0	3600	160	8.07	7.9	24A2BEPM-3RD	—	N4036
1.8	121	1.8	—	—	1/25	1.0	1400	160	8.07	7.9	24A2BEPM-3RD	N4314	—
1.8	121	—	0.3	—	1/29	1.0	1400	160	8.07	7.9	24A2BEPM-3RD	—	N4014
4.2	147	2.6	0.48	—	1/17	1.0	600	160	8.82	8.4	24A4BEPM-3RD	N4306	N4006
8.3	108	2.6	0.48	—	1/17	1.0	300	160	8.82	8.4	24A4BEPM-3RD	N4303	<b>4003</b>
12.5	92	2.6	0.48	—	1/17	1.0	200	160	8.82	8.4	24A4BEPM-3RD	N4302	N4002

## Brushless DC Gearmotors

Speed (rpm)	Torque (lb-in.)	A (Amps)		Peak Torque (lb-in.)	Motor HP	Gear Ratio	Radial Load	Length XH (in.)	Wt. (Ref. lbs.)	Product Type	Model Number	
		24V	130V								24V	130V
<b>TYPE 22B-3RD (non-Integra models)</b>												
0.7	95	2.8	0.48	—	1/16	3600	160	8.17	6.75	22B2BEBL-3RD	N5336	N5036
1.8	121	2.8	0.48	—	1/16	1400	160	8.17	6.75	22B2BEBL-3RD	<b>5314</b>	N5014
4.2	147	2.8	0.48	—	1/16	600	160	8.17	6.75	22B2BEBL-3RD	N5306	N5006
8.3	144	5.9	0.89	—	1/8	300	160	9.13	7.75	22B4BEBL-3RD	N5303	N5003
12.5	140	5.9	0.89	—	1/8	200	160	9.13	7.75	22B4BEBL-3RD	N5302	N5002

<sup>1</sup> NOTE: Model numbers shown with an N require lead-time, and minimum order quantities apply.

<sup>2</sup> SOA: Contact the factory for detailed speed/torque information (Safe Operating Area). See page 37.

# Double Reduction Right Angle AC, DC, and Brushless DC Gearmotors

Up to 148 lb-in. continuous

**NEW!**

**30R-3RD Right Angle AC Gearmotor** (photo shown with optional terminal box, model 5982)

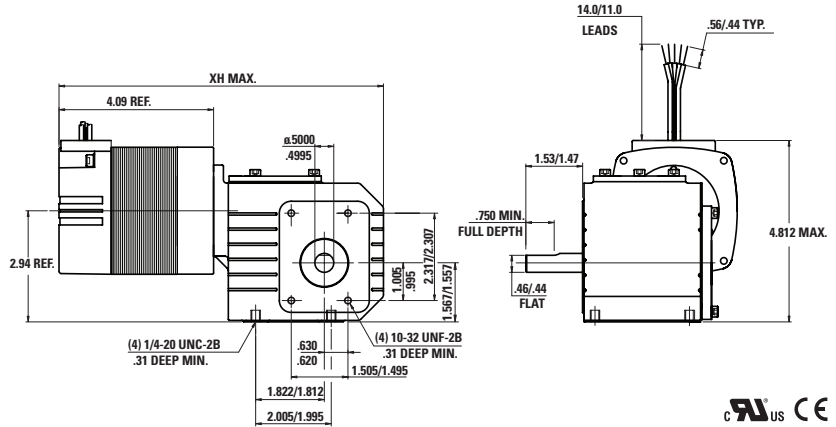
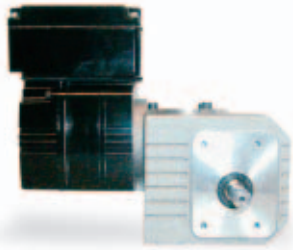

**24A-3RD Right Angle DC Gearmotor** (custom model shown in photo)

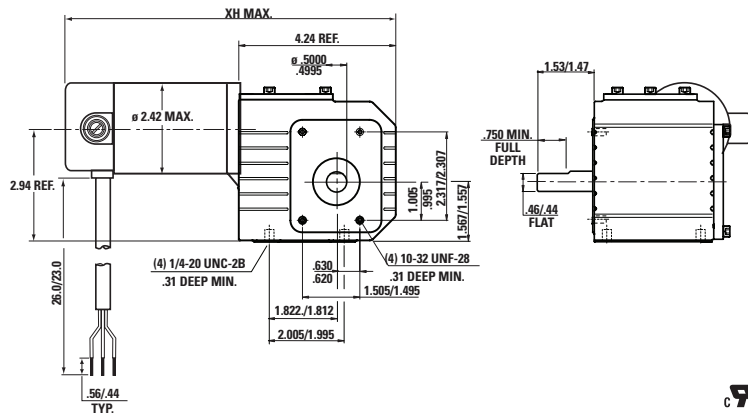

**22B-3RD Right Angle Brushless DC Gearmotor** (custom model shown in photo)

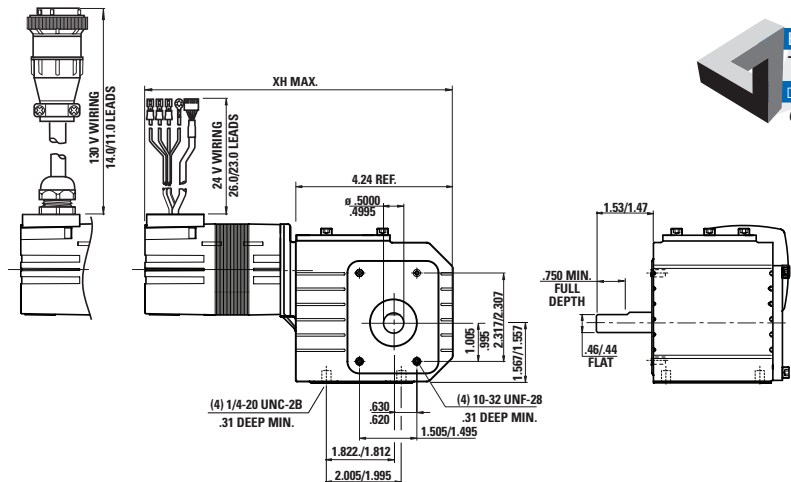
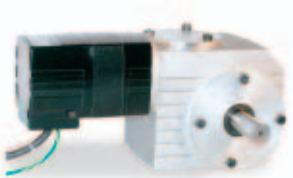

**MADE IN U.S.A.**

NEW!  
 e-TORQ™  
 INTEGRAmotor™  
 Hollow Shaft  
 Custom  
 Pacesetter™ Inverter Duty  
 AC Induction  
 Permanent Magnet DC  
 Brushless DC  
 Index

# Type HG Parallel Shaft AC and DC Gearmotors

Up to 1,000 lb-in. continuous

The HG gearhead provides flexible mounting and high torque in a small package. Typical applications include conveyor systems, food processing equipment, and factory automation.

The type HG gearmotors are available with Bodine's 42R AC induction, and 33A permanent magnet DC. Brushless models are available as built-to-order models. This new gearmotor design utilizes three-stages of gearing, providing gear ratios from 27:1 to 108:1. The gearmotor produces up to 1,000 lb-in. continuous torque and outputs from 16 to 93 rpm. For increased radial load capacity and long life,

the HG gearheads are unvented with needle bearings for the intermediate gear stages, and large ball bearings on the output shaft. They also feature selectively hardened helical and spur gearing for quietness and high output-to-size ratio. The gearmotors are offered with a variety of built-to-order shaft options, including single, double or hollow shaft configurations. Hollow shaft units can be connected directly to the driven load, which saves space and eliminates unnecessary parts that are bulky and present alignment issues. Type HG, integral gearmotors can be face-mounted from either side for maximum flexibility in mounting configurations.



## Offset Parallel Shaft AC Induction Gearmotors

Speed (rpm)	Rated Torque (lb-in.)	Power (HP)	V	Frequency (Hz)	Ph	A (Amps)	Gear Ratio	Radial Load (lbs.)	Connection Diagram	Capacitor	Wt. (lbs.)	Product Type	Model Number <sup>1</sup>
<b>Permanent Split Capacitor, Non-Sync, TEFC</b>													
16	599	1/5	115	60	1	2.7	108	350	074 10297	494 01090	20	42R6BFCEI-HG	N5255
30	310	1/5	115	60	1	2.7	56	350	074 10297	494 01090	20	42R6BFCEI-HG	<b>5257</b>
38	250	1/5	115	60	1	2.7	45	350	074 10297	494 01090	20	42R6BFCEI-HG	N5258
63	150	1/5	115	60	1	2.7	27	350	074 10297	494 01090	20	42R6BFCEI-HG	N5259
<b>Inverter Duty, Three-Phase, Non-Sync, TEFC, SOA<sup>2</sup> Frequency Range: 10-90 Hz, (PACESETTER™)</b>													
16	1,000 <sup>2</sup>	3/8	230	60	3	1.9	108	350	074 10007	—	20	42R6BFPP-HG	<b>2245</b>
30	600 <sup>2</sup>	3/8	230	60	3	1.9	56	350	074 10007	—	20	42R6BFPP-HG	N2247
38	480 <sup>2</sup>	3/8	230	60	3	1.9	45	350	074 10007	—	20	42R6BFPP-HG	N2248
63	289 <sup>2</sup>	3/8	230	60	3	1.9	27	350	074 10007	—	20	42R6BFPP-HG	<b>2249</b>

## Offset Parallel Shaft DC Gearmotors

Speed (rpm)	Rated Torque (lb-in.)	Rated Current (Amps)	HP	Form Factor	Gear Ratio	Radial Load	Wt. (lbs.)	Product Type	Model Number <sup>1</sup>	
									Acc'y Shaft	No Acc'y Shaft
<b>24V Models With Class F Ratings</b>										
23	680	12	1/6 / 1/3	—	108	350	16	33A7BEPH-HG	N6823	N6423
45	353	12	1/6 / 1/3	—	56	350	16	33A7BEPH-HG	<b>6845</b>	N6445
56	284	12	1/6 / 1/3	—	45	350	16	33A7BEPH-HG	N6856	<b>6456</b>
93	170	12	1/6 / 1/3	—	27	350	16	33A7BEPH-HG	N6893	N6493
<b>90V / 130V Models With Class F Ratings</b>										
16 / 23	481 / 680	1.8 / 2.4	1/6 / 1/3	1.4 / 1.0	108	350	16	33A7BEPH-HG	N6323	<b>6023</b>
31 / 45	249 / 353	1.8 / 2.4	1/6 / 1/3	1.4 / 1.0	56	350	16	33A7BEPH-HG	<b>6345</b>	N6045
38 / 56	200 / 284	1.8 / 2.4	1/6 / 1/3	1.4 / 1.0	45	350	16	33A7BEPH-HG	N6356	N6056
64 / 93	120 / 170	1.8 / 2.4	1/6 / 1/3	1.4 / 1.0	27	350	16	33A7BEPH-HG	N6393	<b>6093</b>

<sup>1</sup> NOTE: Model numbers shown in bold type are in stock. "N" model numbers require lead time and minimum quantities.

<sup>2</sup> SOA: Contact the factory for detailed speed/torque information (Safe Operating Area). See page 37.

# Type HG Parallel Shaft AC and DC Gearmotors

Up to 1,000 lb-in. continuous

**NEW!**

## 42R-HG Parallel shaft AC Gearmotor

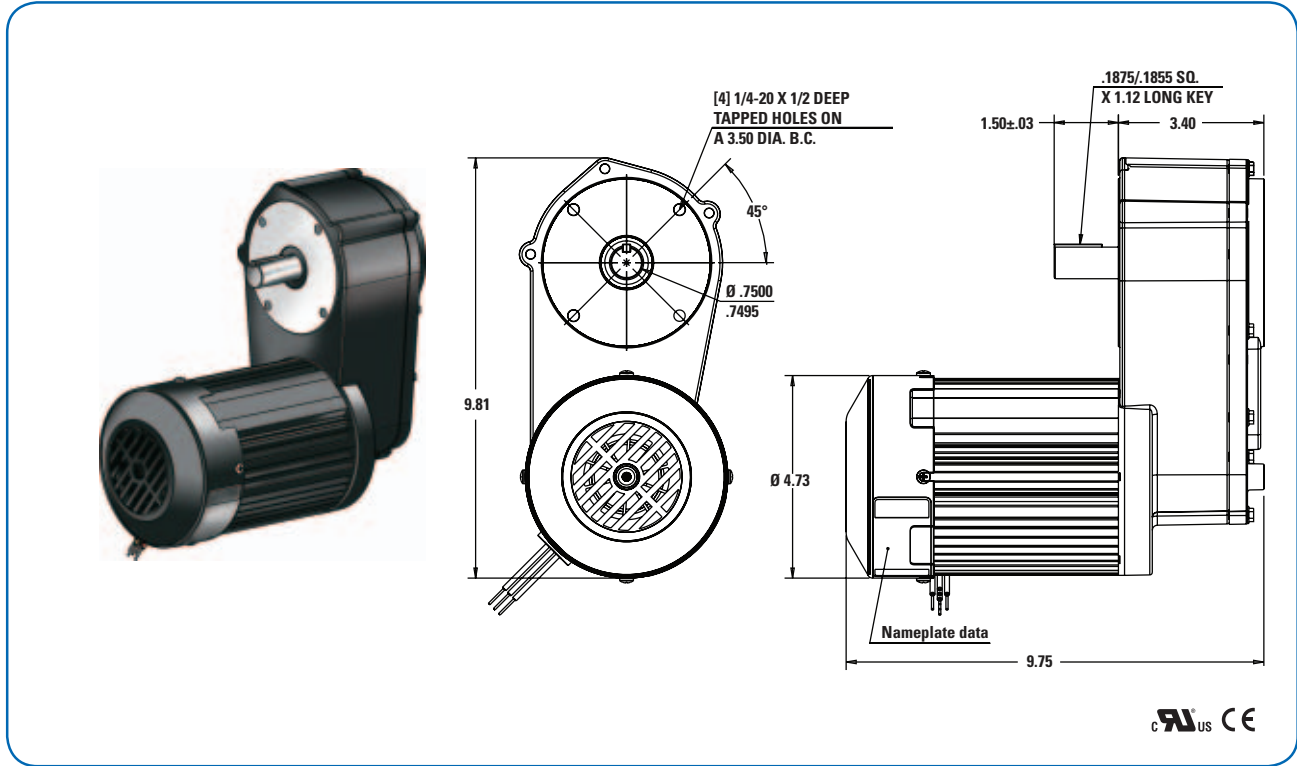

## 33A-HG Parallel shaft DC Gearmotor

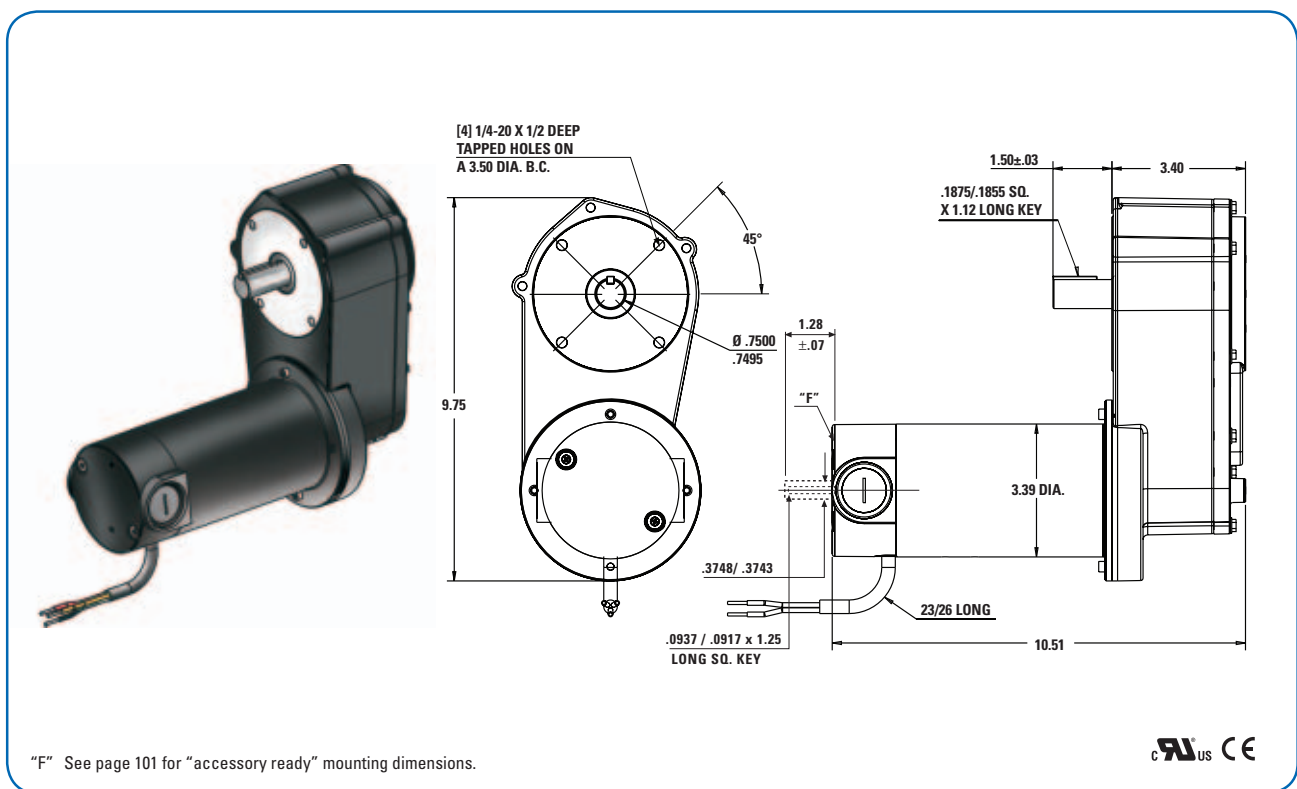

# e-TORO™

Introducing the new standard e-TORO models.

The e-TORO motor design was developed using the Lorentz-force principles to improve efficiency, minimize size and maximize torque. Imagine a gearless motor capable of developing very high torque in the most efficient manner. For more information, CAD drawings and detailed specifications, visit our website.

## What is e-TORQ™?

Unlike virtually all motors today, which are based on electro-magnetic principles first described by Faraday, the e-TORQ™ motor is based on the principles developed by H. A. Lorentz. While motors based on Faraday's principles are the most common today, they may not be the most efficient due to the interaction of the magnetic and mechanical forces inherent in the design.

Both, Lorentz and Faraday's motors use the electromagnetic properties to create mechanical work, but the way the forces are applied in a Faraday motor means the motor is always trying to "reshape" itself. By contrast, the e-TORQ™ motor's design allows the maximum application of electromagnetic forces with almost no mechanical energy losses.

## Why you should be using an e-TORQ™ brushless DC Servo system

When combined with a high performance digital amplifier, the Bodine e-TORQ™ system becomes an easy-to-set-up, high performance motion control solution. e-TORQ™ motors can eliminate the need for a planetary gearhead, or other mechanical gear reduction methods.

Exploded view of 7" flange mount motor

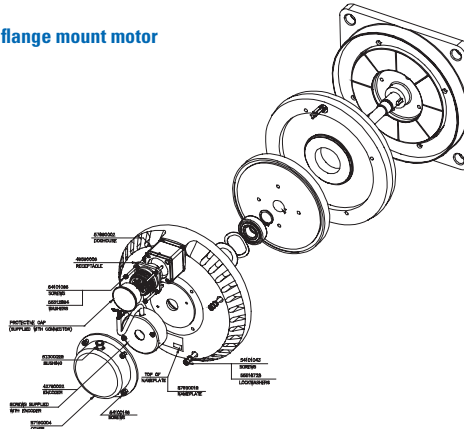

### e-TORQ™ motors provide:

- Zero cogging at slow speeds
- No maintenance
- No lubricants to leak
- High accuracy
- High torque
- High reliability
- Quiet operation
- Alternative to planetary gearmotors
- Wide variety of feedback options
- Custom solutions available
- Expert engineering support for motor and controls

### Available features:

- Two frame sizes 7" and 14"
- Up to 25 lb-in for 7" dia., up to 250 lb-in for 14" dia. motor
- Smooth operation without cogging & vibration
- Ironless stator design
- High torque linearity
- Multiple windings are possible at any voltages between 12v–300 Volts
- Patented technology

### To specify e-TORQ, answer these typical application questions:

- 1 What type of process is the motion being applied to?
- 2 What type of load is associated with the application?
- 3 Are heavy inertial loads involved?
- 4 Motion parameters, i.e. positioning accuracy, min/max speed, accel/decel rates, duty cycle?
- 5 Motion requirements: simple position or velocity? Multi-axis synchronized?
- 6 What type of feedback? Encoder? Resolver? Incremental or Absolute?
- 7 Mechanical Features? Shaft? Mounting? Connector? IP Rating?
- 8 Special Mods: Paint, surface finish, flanges, brackets, brakes, oversized bearings,...

## e-TORQ™ Amplifier Options

Bodine can offer a wide range of solutions for your motion control needs. Using our own proprietary designs or products that we have tested and selected from established suppliers of electronic drives, we can provide the right solution for your BLDC servo system. Our engineers can recommend an electronic solution for your application, or provide a turnkey drive system including a tuned amplifier, feedback device and cables for your specialized application

### Amplifier Type

<b>Trapezoidal PWM</b>	Analog regenerative amplifier with universal AC input voltage (115 to 230VAC) for general velocity control applications where low speed operation is not the primary concern and the system is more cost sensitive.
<b>Sinusoidal PWM</b>	Digital regenerative amplifier with universal AC input voltage for systems where low speed performance and motion quality is crucial. Programmable for motor parameters, commutation functions, input and output functions, gain parameters and feedback parameters. Provides the ultimate in consistency from system to system because digital application parameters can be optimized, stored and re-used on multiple systems. Communications capabilities can include RS-485/RS-232 or the CAN Open network protocol.





# e-TORQ

Up to 200 lb-in. continuous

## What makes the e-TORQ™ motor so unique:

The ironless stator of the e-TORQ™ motor eliminates the iron saturation common to most other types of motors, and allows the motor to run smoothly at extremely low speeds, even when powered by a standard drive.

In addition, the high peak torque capability can allow—in certain applications—the elimination of costly gear-boxes and the reduce the risk of lubricant leaks.

## Application Information

- Standard 7 inch motor supplied with 2048 PPR encoder
- Standard 14 inch motor supplied with 8192 PPR encoder
- Visit our website for CAD drawings and detailed specifications

## Standard Features

- Iron free stator eliminates motor cogging (Detent Torque) which improves low speed control
- No iron saturation for maximum torque linearity
- No lamination core losses that yields very high efficiency
- Ten times peak torque is available



DC Bus Voltage (VDC)	Continuous Rating				Peak Ratings			Motor Constants				Model Number <sup>1</sup>
	Speed (rpm)	Torque (lb-in.)	Current (Amps)	Power Output (Watts)	Speed (rpm)	Torque (lb-in.)	Current (A-rms)	Ke (V/krpm)	Kt (lb-in./Amp)	Resistance (Ohms)	Inductance (mH)	
<b>7 in. e-TORQ Motor, Flange Mount</b>												
130/260	2500/5000	20/19	5.5/5.3	590/1230	6000	200	45	42.50	3.88	2.16	1.5	N60501400
<b>7 in. e-TORQ Motor, Face Mount</b>												
130/260	2500/5000	20/16	5.5/4.6	590/1040	6000	200	45	42.50	3.88	2.16	1.5	N60501390
<b>14 in. e-TORQ Motor, Face Mount</b>												
130/260	1150	200	21	2700	2000	2000	200	96.1	8.22	0.119	0.090	N60500520

<sup>1</sup> NOTE: Model numbers shown in bold type are in stock. "N" model numbers require lead time and minimum quantities.

7-inch Flange Mount

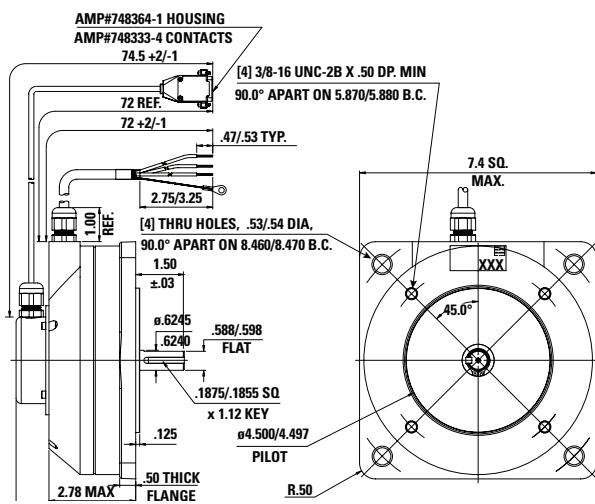

7-inch Face Mount

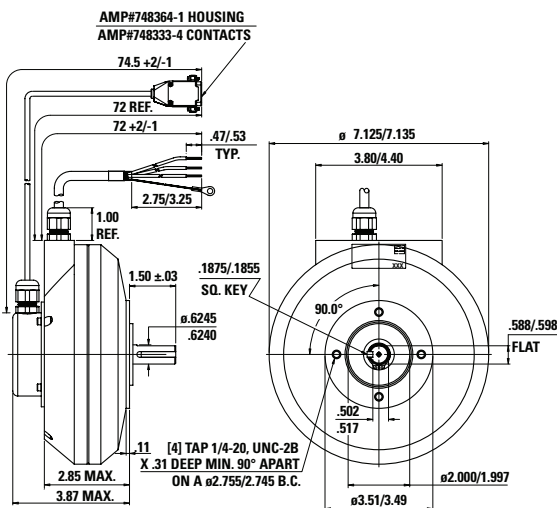



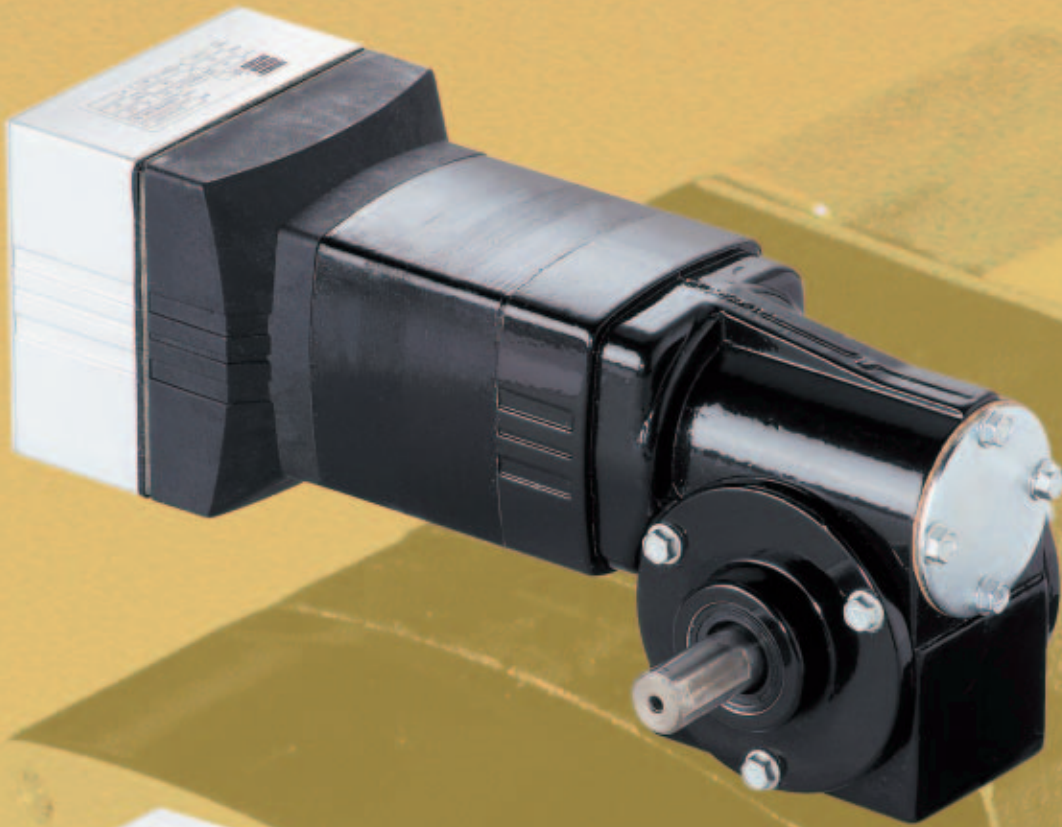

**Low Voltage  
24 VDC**

**BRUSHLESS DC MOTORS/  
GEARMOTORS WITH BUILT-IN  
CONTROLS**

Bodine Electric's Brushless DC *INTEGRAmotor*<sup>™</sup> products combine three Bodine strengths into one powerful package that reduces wiring, panel space, assembly time, and system cost.

Bodine has been manufacturing small motors for over 100 years and has long been acknowledged as the leader in manufacturing high quality, long-lasting small gearmotors. And Bodine has the engineering capability and the state-of-the-art automated assembly equipment for manufacturing modern electronic controls that are small and economical.

**INTEGRAmotors<sup>™</sup>**



22B/FV



# INTEGRAmotor™ Direct Drive Brushless DC Motors

1/16 - 1/8 HP

Bodine Electric's new **INTEGRAmotor™** Brushless DC products integrate three motion control components into one compact package. The perfect match of motor, speed control, and gearhead provide simplified wiring, reduced panel space, faster assembly times, and lower system costs.

### NEW! PWM Input Models

The new type 22B/FV models combine a 24VDC Brushless DC Motor with a built-in, open loop, voltage mode PWM controller. They accept PWM input from an external motion or speed controller, and feature amplifier enable, direction input, dynamic braking, and a built-in, 256 PPR, 2-channel encoder. These models are designed to be used in applications that would typically require more costly stepper or high-end servo motors. **Please visit our website for detailed information on the new 22B/FV series.**

### 22B/SR Features

- Integral control simplifies installation, minimizes EMI & reduces wiring cost
- Totally enclosed motor construction
- Single plug-in connector for power & logic
- Inputs for run, brake, speed, & direction
- 12 pulse/revolution tach output
- Dynamic braking for quick stops
- Current limit protects motor from overload
- Small size takes up minimal space
- cURus (UL recognized for USA and Canada), CE
- For our complete line of brushless products see page 103

Motor Output		Control Input			Length XH (inch)	Weight (lbs.)	Product Type	Model Number
Speed Range (rpm)	Torque (oz-in.)	HP	Volts (VDC)	Continuous Amps				
200-2500	25	1/16	24	4.0	4.7	2.5	22B2BEBL/SR	3802
200-2500	50	1/8	24	6.0	5.7	3.5	22B4BEBL/SR	3804

### 22B/SR and 22B/FV INTEGRAmotor™

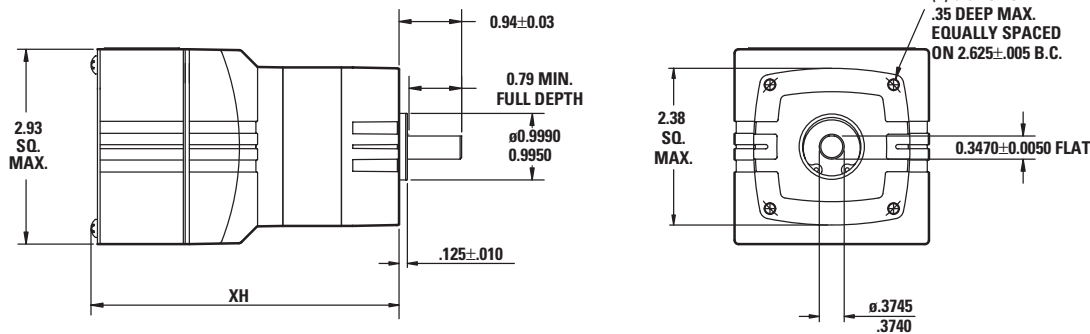

Note: all direct drive INTEGRAmotor models have the same mounting hole dimensions.



# INTEGRAmotor™ Parallel Shaft BLDC Gearmotors

Up to 100 lb-in. continuous

Bodine Electric's new **INTEGRAmotor™** Brushless DC products integrate three motion control components into one compact package. The perfect match of motor, speed control, and gearhead provide simplified wiring, reduced panel space, faster assembly times, and lower system costs.

### NEW! PWM Input Models

The new type 22B/FV models combine a 24VDC Brushless DC Motor with a built-in, open loop, voltage mode PWM controller. They accept PWM input from an external motion or speed controller, and feature amplifier enable, direction input, dynamic braking, and a built-in, 256 PPR, 2-channel encoder. These models are designed to be used in applications that would typically require more costly stepper or high-end servo motors. **Please visit our website for detailed information on the new 22B/FV series.**

### Same Features as 22B/SR Direct Drive Motors, PLUS:

- Integral gear reducer increases torque and reduces speed
- Helical & spur gearing for high efficiency
- Oil lubrication for long life
- Unvented gearhousing for universal, horizontal mounting
- High-strength thermoplastic input gear for quiet operation
- Output torque ratings chosen for long, reliable life
- For our complete line of brushless products see page 103

### Optional Accessories

- "L" bracket kit model 5968, see page 122



22B-D and 22B-Z



New e-TORQ™

INTEGRAmotor™

Motor Output			Control Input			Length XH (inch)	Weight (lbs.)	Product Type	Model Number <sup>1</sup>
Speed Range (rpm)	Torque (lb-in.)	Gear Ratio	HP	Volts (VDC)	Continuous Amps				
0.7-8	100	300:1	1/16	24	4.0	7.9	4.8	22B2BEBL/SR-Z4	N3864
0.7-8	40	300:1	1/16	24	4.0	6.7	3.8	22B2BEBL/SR-D5	N3837
1-14	100	180:1	1/16	24	4.0	7.9	4.8	22B2BEBL/SR-Z4	<b>3863</b>
1-14	40	180:1	1/16	24	4.0	6.7	3.8	22B2BEBL/SR-D4	<b>3836</b>
2-28	97	90:1	1/16	24	4.0	7.9	4.8	22B2BEBL/SR-Z4	N3862
2-28	40	90:1	1/16	24	4.0	6.7	3.8	22B2BEBL/SR-D4	N3835
3-42	95	60:1	1/11	24	5.0	8.4	5.3	22B3BEBL/SR-Z3	N3861
3-42	40	60:1	1/16	24	4.0	6.7	3.8	22B2BEBL/SR-D3	N3834
7-83	52	30:1	1/11	24	5.0	8.4	5.3	22B3BEBL/SR-Z3	<b>3860</b>
7-83	29	30:1	1/16	24	4.0	6.7	3.8	22B2BEBL/SR-D3	<b>3829</b>
11-139	31	18:1	1/11	24	5.0	7.4	5.3	22B3BEBL/SR-Z2	N3859
11-139	17	18:1	1/16	24	4.0	6.7	3.8	22B2BEBL/SR-D3	N3828
17-208	20	12:1	1/11	24	5.0	7.4	5.3	22B3BEBL/SR-Z2	N3858
17-208	12	12:1	1/16	24	4.0	6.7	3.8	22B2BEBL/SR-D3	<b>3827</b>
33-417	10	6:1	1/11	24	5.0	7.4	5.3	22B3BEBL/SR-Z2	<b>3857</b>
33-417	5.8	6:1	1/16	24	4.0	6.7	3.8	22B2BEBL/SR-D3	<b>3826</b>

<sup>1</sup> NOTE: Model numbers shown in bold type are in stock. "N" model numbers require lead time and minimum quantities.

### 22B-D and 22B-Z INTEGRAmotor™ (SR and /FV)

#### D gearhead shaft dimension

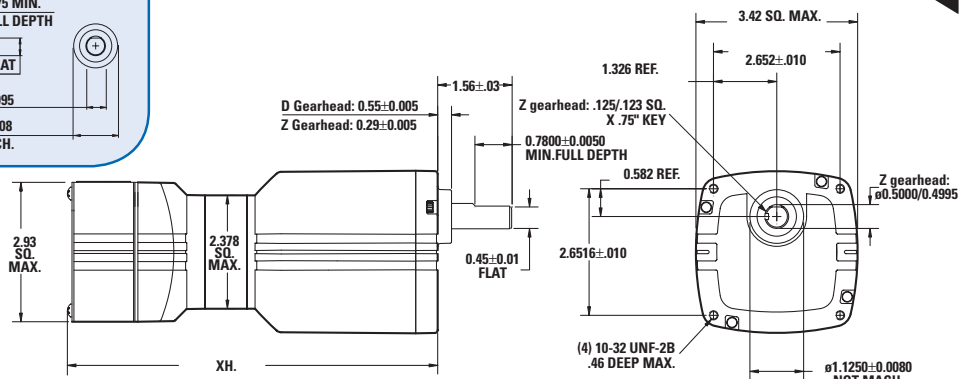
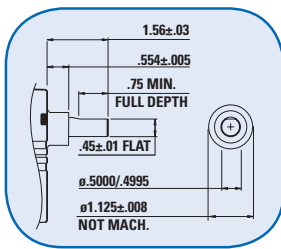

Note: all parallel shaft INTEGRAmotors models have the same mounting hole dimensions. Drive shaft and shaft hub dimensions vary between type D and Z gearheads.



Hollow Shaft

Custom

Pacesetter™ Inverter Duty

AC Induction

Permanent Magnet DC

Brushless DC

Index



22B-3N



# INTEGRAmotor™ Right Angle BLDC Gearmotors

Up to 37 lb-in. continuous

Bodine Electric's new **INTEGRAmotor™** Brushless DC products integrate three motion control components into one compact package. The perfect match of motor, speed control, and gearhead provide simplified wiring, reduced panel space, faster assembly times, and lower system costs.

### NEW! PWM Input Models

The new type 22B/FV models combine a 24VDC Brushless DC Motor with a built-in, open loop, voltage mode PWM controller. They accept PWM input from an external motion or speed controller, and feature amplifier enable, direction input, dynamic braking, and a built-in, 256 PPR, 2-channel encoder. These models are designed to be used in applications that would typically require more costly stepper or high-end servo motors. **Please visit our website for detailed information on the new 22B/FV series.**

### Same Features as 22B/SR Direct Drive Motors, PLUS:

- Integral gear reducer increases torque and reduces speed
- Worm gearing for high strength & quiet operation
- Higher gear ratios provide self-locking to hold load in place
- Grease lubrication for long life & flexible mounting positions
- Unvented gearhousing
- Output torque ratings chosen for long, reliable life
- For our complete line of brushless products see page 103
- Hollow shaft configurations are available. See page 19 for mounting and shaft details. These models require lead time and minimum quantities.

### Optional Accessories

- Baseplate kit model 0967, see page 122

Motor Output			Control Input			Length XH (inch)	Weight (lbs.)	Product Type	Model Number <sup>1</sup>
Speed Range (rpm)	Torque (lb-in.)	Gear Ratio	HP	Volts (VDC)	Continuous Amps				
3-42	37	60:1	1/8	24	6.0	8.79	5.4	22B4BEBL/SR-3N	N3865
5-62	37	40:1	1/8	24	6.0	8.79	5.4	22B4BEBL/SR-3N	<b>3866</b>
10-125	35	20:1	1/8	24	6.0	8.79	5.4	22B4BEBL/SR-3N	N3867
20-250	22	10:1	1/8	24	6.0	8.79	5.4	22B4BEBL/SR-3N	<b>3868</b>
40-500	11	5:1	1/8	24	6.0	8.79	5.4	22B4BEBL/SR-3N	N3869

<sup>1</sup> NOTE: Model numbers shown in bold type are in stock. "N" model numbers require lead time and minimum quantities.

### 22B-3N IntegrAmotor™

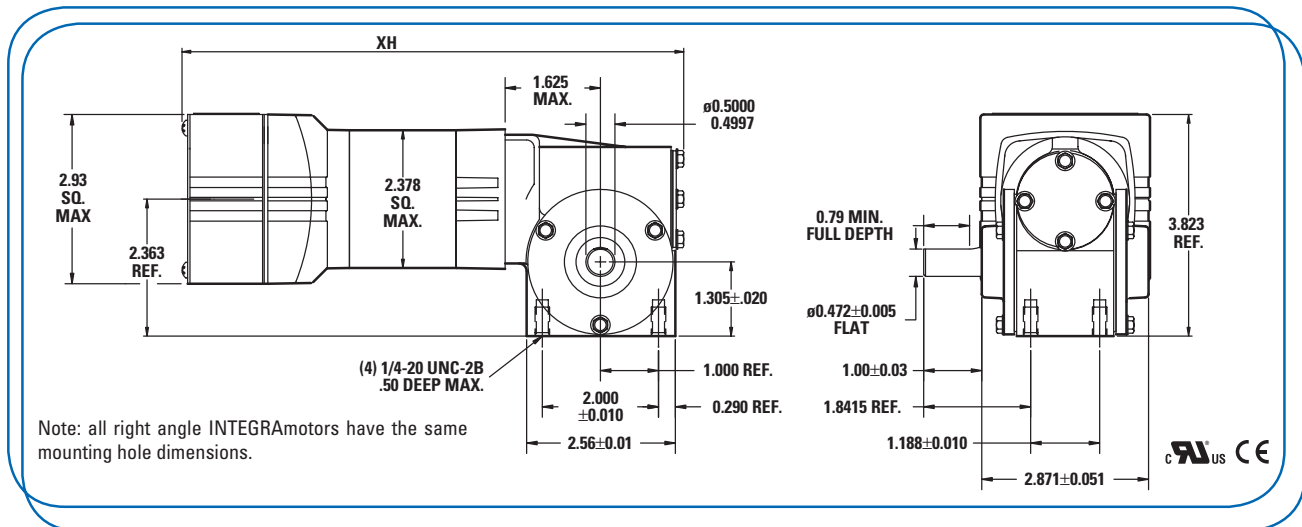

Note: all right angle INTEGRAmotors have the same mounting hole dimensions.

### ELECTRICAL CONNECTIONS FOR ALL 22B/SR INTEGRAmotors

(visit our website for 22B/FV connections and pin-out information)

Rear View of INTEGRAmotor

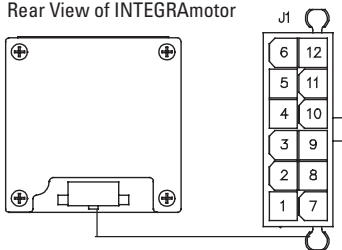

Mating Connector Housing is Molex P/N 39-01-2125

Power Pin No.	Description
1	24V Return (Common)
7	+24V

Mating Receptacle is Molex P/N 39-00-0039 (loose piece) for 18 – 24 AWG wire

Logic Pin No.	Description	Logic Pin No.	Description
2	Direction	8	Tach (12 PPR)
3	Enable (Active low)	9	Voltage Input (Speed)
4	Fault (Active low)	10	+5V (Use for speed pot only)
5	<b>New:</b> Direction Output	11	Brake (Active low)
6	Common	12	Common

Mating Receptacle is Molex P/N 39-00-0047 (loose piece) for 22 – 28 AWG wire

NOTE: Use Molex Hand Tool P/N 57026-5000 to crimp the receptacles to the wires.



- 38 stock or nonstock models available
- AC and DC and Brushless DC models available
- Motor ratings from 1/11-3/4 HP
- Gear ratios from 5:1 to 280:1
- Torque ratings from 8.2-380 lb-in.
- Bore sizes from 1/2" to 1" diameter
- Most of our stocked right-angle gearmotors can be ordered as special order hollow shaft versions. See our website for details

# Hollow Shaft Gearmotors

# Hollow Shaft AC Gearmotors

Up to 121 lb-in. continuous



42R-5L/H



### Standard Features

- Quinsulation™ 5-stage insulation system designed to meet NEMA MG 1-1993, Section IV, Part 31.
- Inverter-Grade magnet wire and Class "F" insulation system for increased protection against spikes and corona damage caused by the inverter.
- UL recognized, CSA certified, CE mark. Totally enclosed IP-20 rating.
- Fan cooled for high output power.
- Unvented gearhousing for universal horizontal mounting.
- Industrial lip type seals on motor and output shafts.
- Ball bearings on output shaft for quietness.
- Permanently lubricated gearing utilizing oil for long life.
- Bronze gear for high shock load capability.
- Hardened and ground worm for high strength and long life.
- A solid shaft version of this product is available

### Application Information

- Threaded mounting holes are located on both sides of gearhead.

### Optional Accessories

- Die cast terminal box kit model 0984,1984 achieves IP-44 rating.
- Stamped terminal box kit model 0982.

### Matching Controls

- We stock a full line of speed controls for our Pacesetter motors.

Fixed Speed Ratings					Variable Speed (SOA) Ratings <sup>2</sup>						XH (inch)	Wt. (lbs.)	Connection Diagram	Order Information	
Speed (rpm)	Torque (lb-in.)	Motor HP	V	Gear Ratio	Speed Range (rpm)	Frequ. (Hz)	Torque Type	Torque @						Product Type	Model No. <sup>1</sup>
								10 Hz (lb-in.)	60 Hz (lb-in.)	90 Hz (lb-in.)					
<b>Three-Phase, Inverter Duty, Non-Synchronous (TEFC)</b>															
23	121	3/8	230	75	2.4-31	10-90	variable	121	121	116	10.75	17.5	074 10007	42R6BFPP-5L/H	<b>N2470</b>
43	113	3/8	230	40	4.4-57	10-90	constant	109	109	109	10.75	17.5	074 10007	42R6BFPP-5L/H	<b>N2471</b>
57	109	3/8	230	30	5.9-77	10-90	constant	104	104	104	10.75	17.5	074 10007	42R6BFPP-5L/H	<b>N2475</b>
85	103	3/8	230	20	8.9-115	10-90	constant	98	98	98	10.75	17.5	074 10007	42R6BFPP-5L/H	<b>2472</b>
170	101	3/8	230	10	18-229	10-90	variable	66	105	101	10.75	17.5	074 10007	42R6BFPP-5L/H	<b>N2473</b>
340	54	3/8	230	5	35-458	10-90	variable	38	68	59	10.75	17.5	074 10007	42R6BFPP-5L/H	<b>N2474</b>

<sup>1</sup> NOTE: Model numbers shown in bold type are in stock. "N" model numbers require lead time and minimum quantities.

<sup>2</sup> SOA: Contact the factory for detailed speed/torque information (Safe Operating Area). See page 37.

### 42R-5L/H Hollow Shaft Gearmotor

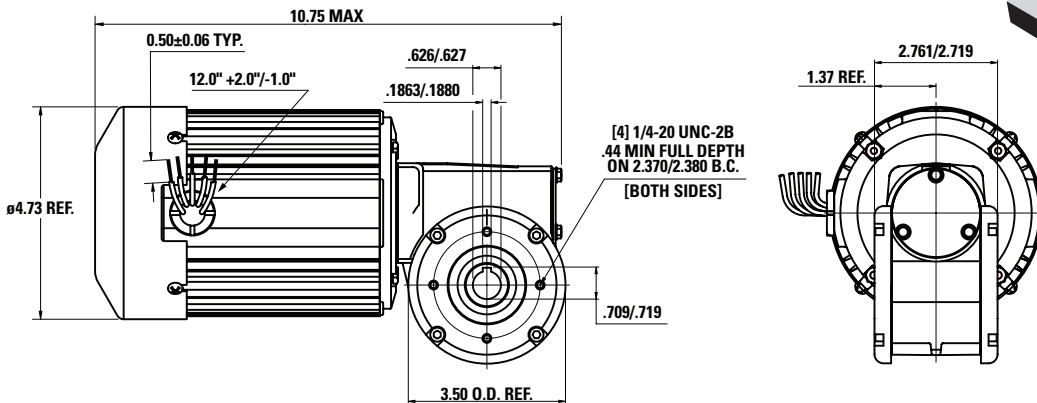

# Hollow Shaft AC Gearmotors

Up to 380 lb-in. continuous

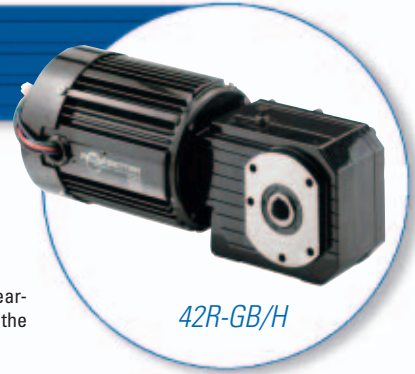

42R-GB/H

## Product Features

- Quintsulation™ 5-stage insulation system designed to meet NEMA MG 1-1993, Section IV, Part 31.
- Inverter-Grade magnet wire and Class "F" insulation system for increased protection against spikes and corona damage caused by the inverter.
- UL recognized, CSA certified, CE mark.
- Totally enclosed IP-20 rating.
- Fan cooled for high output power.
- Unvented gearhousing for universal horizontal mounting.
- Industrial lip type seals on motor and output shafts.
- Ball bearings on output shaft for quiet operation, increased radial load capacity, and long life.
- Hardened helical output gearing for quietness and high output torque.
- Permanently lubricated gearing utilizing oil for long life.

- Bronze gear for high shock load capability.
- Hardened and ground worm for high strength and long life.
- A solid shaft version of this product is available.

## Application Information

- 3-point mount, tapped holes on both sides of gearhead face, and four tapped mounting holes under the gearhead.

## Optional Accessories

- Die cast terminal box kit model 0984,1984 achieves IP-44 rating.
- Stamped terminal box kit model 0982.

## Matching Controls

- We stock a full line of speed controls for our Pacesetter motors.



Fixed Speed Ratings					Variable Speed (SOA) Ratings <sup>2</sup>						XH (inch)	Wt. (lbs.)	Connection Diagram	Order Information	
Speed (rpm)	Torque (lb-in.)	Motor HP	V	Gear Ratio	Speed Range (rpm)	Frequ. (Hz)	Torque Type	Torque @						Product Type	Model No. <sup>1</sup>
								10 Hz (lb-in.)	60 Hz (lb-in.)	90 Hz (lb-in.)					
<b>Three-Phase, Inverter Duty, Non-Synchronous (TEFC)</b>															
6	380	3/8	230	280	0.6-8.2	10-90	constant	380	380	380	12.1	19.5	074 10007	42R6BFPP-GB/H	<b>2336</b>
14	290	3/8	230	120	1.5-19	10-90	constant	290	290	290	12.1	19.5	074 10007	42R6BFPP-GB/H	N2337
28	230	3/8	230	60	3.0-38	10-90	constant	230	230	230	12.1	19.5	074 10007	42R6BFPP-GB/H	N2338

<sup>1</sup> NOTE: Model numbers shown in bold type are in stock. "N" model numbers require lead time and minimum quantities.

<sup>2</sup> SOA: Contact the factory for detailed speed/torque information (Safe Operating Area). See page 37.



42R-GB/H Hollow Shaft Gearmotor

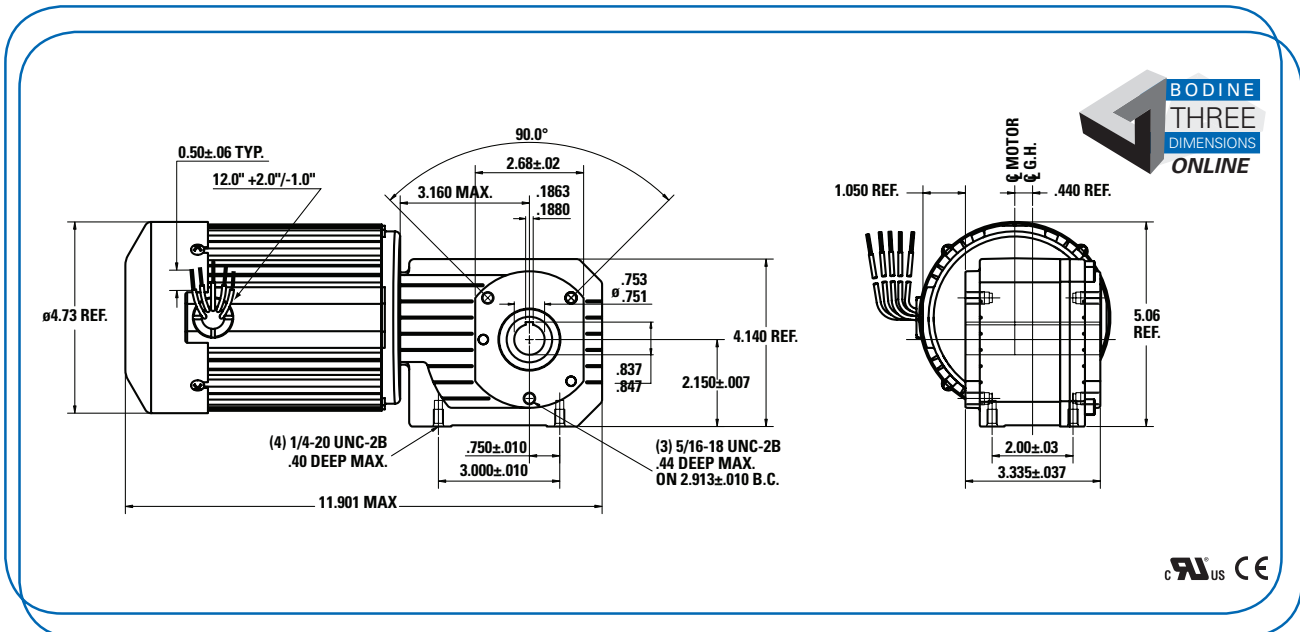

MADE IN U.S.A.

# Hollow Shaft DC Gearmotors

Up to 37 lb-in. continuous



24A-3F/H



## Standard Features

- 24A Motor provides high starting torque, adjustable speed, and predictable performance under a range of operating conditions.
- Industrial lip type seals on motor and output shafts.
- Ball bearing on output shaft for increased radial load capacity and long life.
- Permanently lubricated gearing utilizing semi-fluid grease lubrication for long life.
- Bronze gear for high shock load capability.
- Hardened and ground worm for high strength and long life.

## Application Information

- Performance ratings of 130V models are based on use with filtered controls.
- Gearmotors can be mounted via four tapped holes in bottom of the gearhead or via three tapped holes on the left or right side of the gearhead.

## Optional Accessories

- Encoder model 0940 (can be used only on models that have an accessory shaft).
- Baseplate kit model 0967.

## Matching Controls

- We stock a full line of speed controls for our PMDC motors.

Speed (rpm)	Rated Torque (lb-in.)	Rated Current (Amps)	Peak Torque (lb-in.)	HP	FF	Gear Ratio	Wt. (lbs.)	Product Type	Model Number <sup>1</sup>	
									Acc'y. Shaft	No Acc'y. Shaft
<b>24 V Models With Class F Ratings</b>										
250	14	3.7	—	1/13	—	10	5.3	24A4BEPM-3F/H	—	<b>N7694</b>
500	6.8	3.7	—	1/13	—	5	5.3	24A4BEPM-3F/H	N7893	—
<b>90V/130V Models With Class F Ratings</b>										
29/42	35 / 37	.56 / .81	—	1/23 / 1/11	1.4 / 1.0	60	5.3	24A4BEPM-3F/H	—	<b>7099</b>
43/63	29 / 37	.56 / .81	—	1/23 / 1/11	1.4 / 1.0	40	5.3	24A4BEPM-3F/H	—	<b>7098</b>
86/125	18 / 26	.56 / .81	—	1/23 / 1/11	1.4 / 1.0	20	5.3	24A4BEPM-3F/H	—	<b>7096</b>
173/250	10 / 16	.56 / .81	—	1/23 / 1/11	1.4 / 1.0	10	5.3	24A4BEPM-3F/H	—	<b>7094</b>
345/500	5.5 / 8.2	.56 / .81	—	1/23 / 1/11	1.4 / 1.0	5	5.3	24A4BEPM-3F/H	—	<b>7093</b>

<sup>1</sup> NOTE: Model numbers shown in bold type are in stock. "N" model numbers require lead time and minimum quantities.

## 24A-3F/H Hollow Shaft Gearmotor

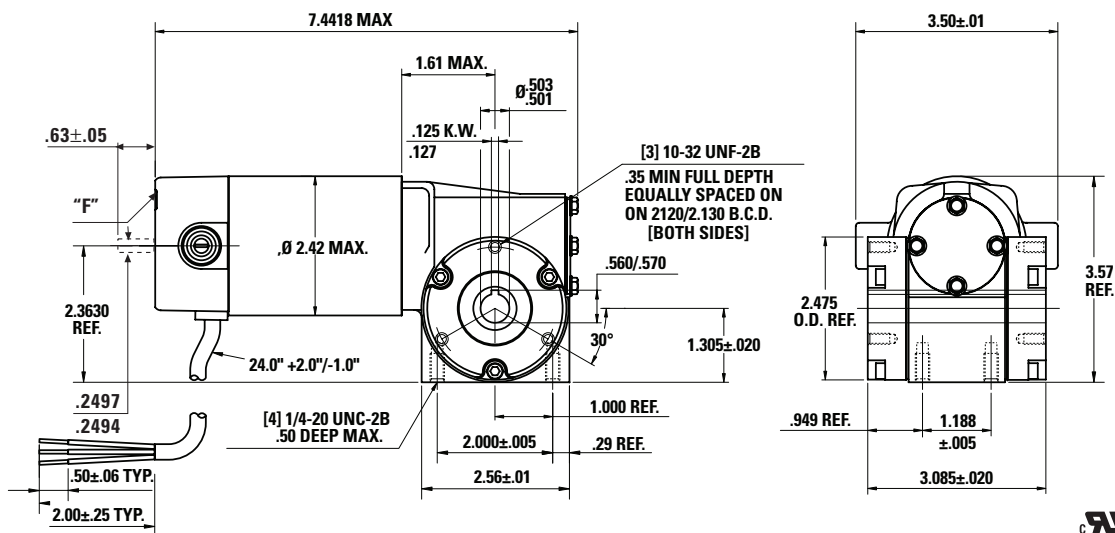

"F" See page 101 for "accessory ready" mounting dimensions.





# Hollow Shaft DC Gearmotors

Up to 109 lb-in. continuous



33A-5L/H



## Standard Features

- 33A Motor provides high starting torque, adjustable speed, and predictable performance under a range of operating conditions.
- Industrial lip type seals on motor and output shafts.
- Ball bearings on output shaft for quietness.
- Permanently lubricated gearing utilizing oil for long life.
- Bronze gear for high shock load capability.
- Hardened and ground worm for high strength and long life.
- Hollow driveshaft for flexibility in mounting.

## Application Information

- Threaded mounting holes are located on both sides of gearhead.
- A solid shaft version of this product is available

## Optional Accessories

- IP-44 achieved with terminal box model 0984 or 1984. Matching Controls
- We stock a full line of speed controls for our PMDC motors.

Speed (rpm)	Rated Torque (lb-in.)	Rated Current (Amps)	Peak Torque (lbs-in.)	HP	FF	Gear Ratio	Wt. (lbs.)	Product Type	Model Number
<b>90/130V Models, Class F</b>									
43/62	84/109	1.4 / 1.8	177	1/8 / 1/4	1.4 / 1.8	40	9.9	33A5BEPM-5L/H	N6738
58/83	75/100	1.4 / 1.8	169	1/8 / 1/4	1.4 / 1.8	30	9.9	33A5BEPM-5L/H	N6737
86/125	54/78	1.4 / 1.8	159	1/8 / 1/4	1.4 / 1.8	20	9.9	33A5BEPM-5L/H	N6736
173/250	31/42	1.4 / 1.8	91	1/8 / 1/4	1.4 / 1.8	10	9.9	33A5BEPM-5L/H	<b>6735</b>
345/500	17/22	1.4 / 1.8	49	1/8 / 1/4	1.4 / 1.8	5	9.9	33A5BEPM-5L/H	N6734

<sup>1</sup> NOTE: Model numbers shown in bold type are in stock. "N" model numbers require lead time and minimum quantities.

## 33A-5L/H Hollow Shaft Gearmotor

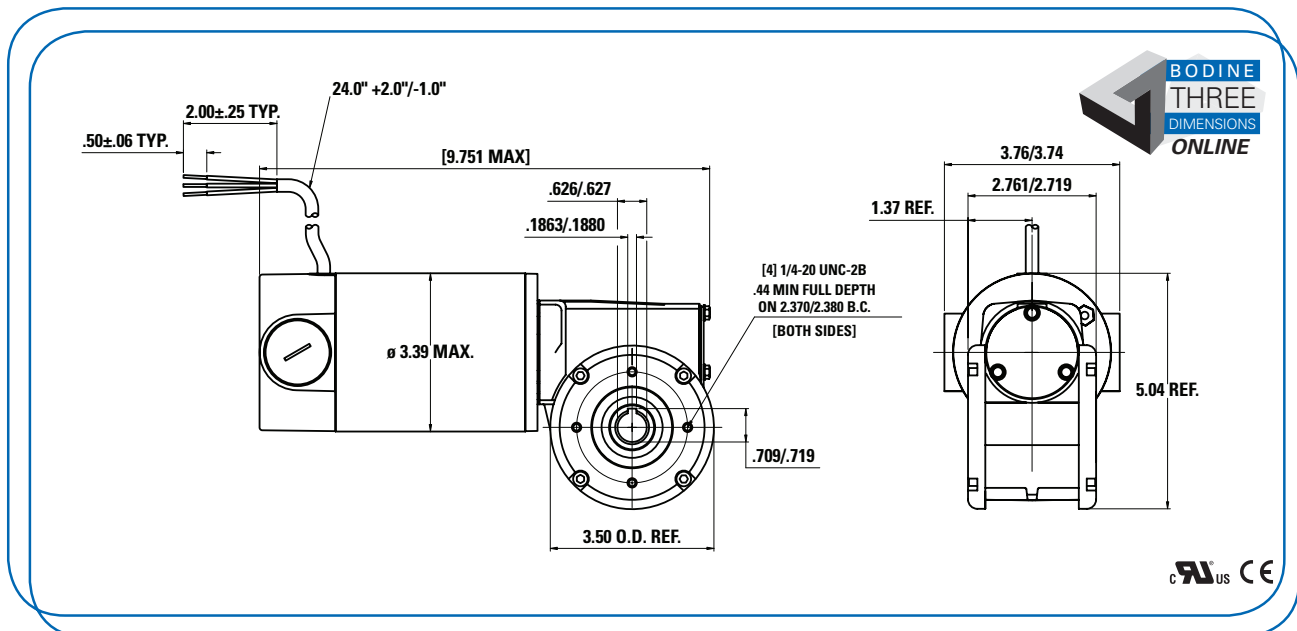



42A-5L/H



# Hollow Shaft DC Gearmotors

Up to 113 lb-in. continuous

### Standard Features

- 42A Motor provides high starting torque, adjustable speed, and predictable performance under a range of operating conditions.
- Industrial lip type seals on motor and output shafts.
- Ball bearings on output shaft for quietness.
- Permanently lubricated gearing utilizing oil for long life.
- Bronze gear for high shock load capability.
- Hardened and ground worm for high strength and long life.
- Hollow driveshaft for flexibility in mounting.

### Application Information

- Threaded mounting holes are located on both sides of gearhead.

### Optional Accessories

- IP-44 achieved with terminal box model 0984 or 1984.

### Matching Controls

- We stock a full line of speed controls for our PMDC motors.

Speed (rpm)	Rated Torque (lb-in.)	Rated Current (Amps)	Peak Torque (lbs-in.)	HP	FF	Gear Ratio	Wt. (lbs.)	Product Type	Model Number
<b>90/130V Models, Class F</b>									
29/42	113/113	2.2 / 2.7	177	1/5 / 3/8	1.4 / 1.0	60	14.3	42A5BEPM-5L/H	<b>7139</b>
43/62	109/109	2.2 / 2.7	177	1/5 / 3/8	1.4 / 1.0	40	14.3	42A5BEPM-5L/H	<b>7138</b>

42A-5L/H Hollow Shaft Gearmotor

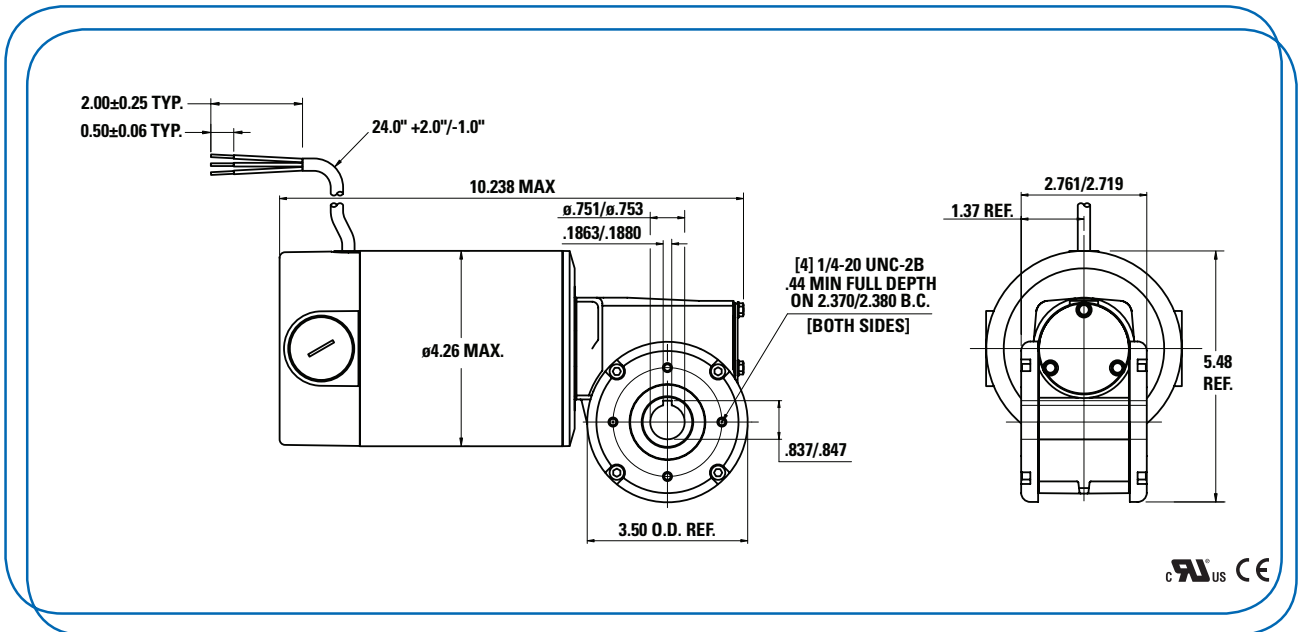

# Hollow Shaft DC Gearmotors

Up to 380 lb-in. continuous



33A-GB/H



## Standard Features

- 33A Motor provides high starting torque, adjustable speed, and predictable performance under a range of operating conditions.
- Unvented gearhousing.
- Industrial lip type seals on motor and output shafts.
- Ball bearing on output shaft for increased radial load capacity and long life.
- Permanently lubricated.
- Hardened helical output gearing for quietness and high output torque.
- Bronze primary worm gear for high shock load capability.
- Hardened and ground worm hobbled on the motor shaft for high strength and long life.

## Application Information

- Mounting is via four tapped holes under the gearhead or three tapped holes in the face of the gearhead.

## Optional Accessories

- IP-44 achieved with terminal box model 0984 or 1984.

## Matching Controls

- We stock a full line of speed controls for our PMDC motors.

Speed (rpm)	Rated Torque (lb-in.)	Rated Current (Amps)	Peak Torque (lbs-in.)	HP	FF	Gear Ratio	Wt. (lbs.)	Product Type	Model Number
<b>90/130V Models, Class F</b>									
6.2 / 8.9	380 / 380	1.4/1/8	600	1/8 / 1/4	1.4/1.0	280	13.6	33A5BEPM-GB/H	7066
9.1 / 13	358 / 375	1.4/1/8	600	1/8 / 1/4	1.4/1.0	190	13.6	33A5BEPM-GB/H	7064
14 / 21	251 / 290	1.4/1/8	464	1/8 / 1/4	1.4/1.0	120	13.6	33A5BEPM-GB/H	7062
29 / 42	151 / 200	1.4/1/8	368	1/8 / 1/4	1.4/1.0	60	13.6	33A5BEPM-GB/H	7060

## 33A-GB/H Hollow Shaft Gearmotor

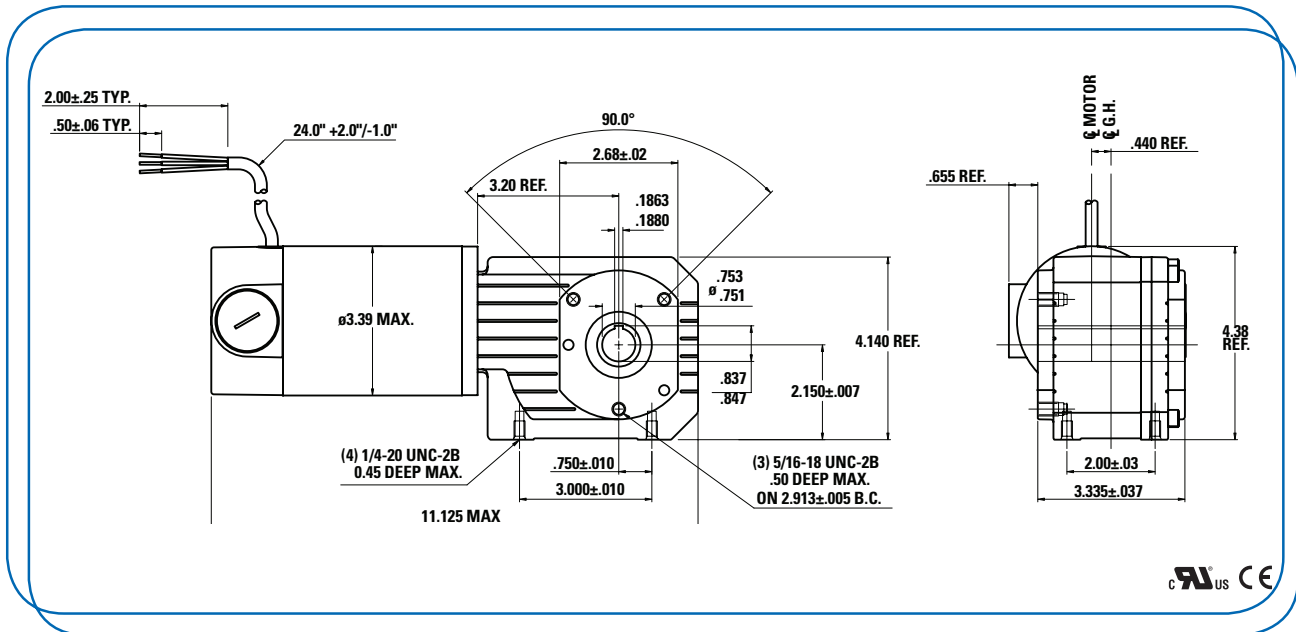

# Hollow Shaft DC Gearmotors

Up to 380 lb-in. continuous

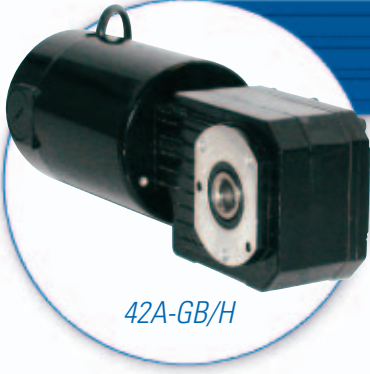

42A-GB/H



### Standard Features

- 42A Motor provides high starting torque, adjustable speed, and predictable performance under a range of operating conditions.
- Unvented gearhousing.
- Industrial lip type seals on motor and output shafts.
- Ball bearing on output shaft for increased radial load capacity and long life.
- Permanently lubricated gearing utilizing oil for long life.
- Hardened helical output gearing for quietness and high output torque.
- Bronze primary worm gear for high shock load capability.
- Hardened and ground worm hobbled on the motor shaft for high strength and long life.
- Hollow driveshaft for flexibility in mounting.

### Application Information

- Performance ratings of 130V models are based on use with filtered controls.
- 3-point mount, tapped holes on both sides of gear-head face, and four tapped mounting holes under the gearhead.

### Optional Accessories

- Encoder model 0941 (can be used only on models that have an accessory shaft).
- Brake model 0997 (can be used only on models that have an accessory shaft).
- IP-44 achieved with terminal box model 0984 or 1984.
- IP-44 achieved with boot kit model 0978.

### Matching Controls

- We stock a full line of speed controls for our PMDC motors.

Speed (rpm)	Rated Torque (lb-in.)	Rated Current (Amps)	Peak Torque (lbs-in.)	HP	FF	Gear Ratio	Wt. (lbs.)	Product Type	Model Number
<b>130V Models, Class B</b>									
8.9	380	1.8	600	1/4	1.0	280	13.6	42A5FPM-GB/H	7466

## 42A-GB/H Hollow Shaft Gearmotor

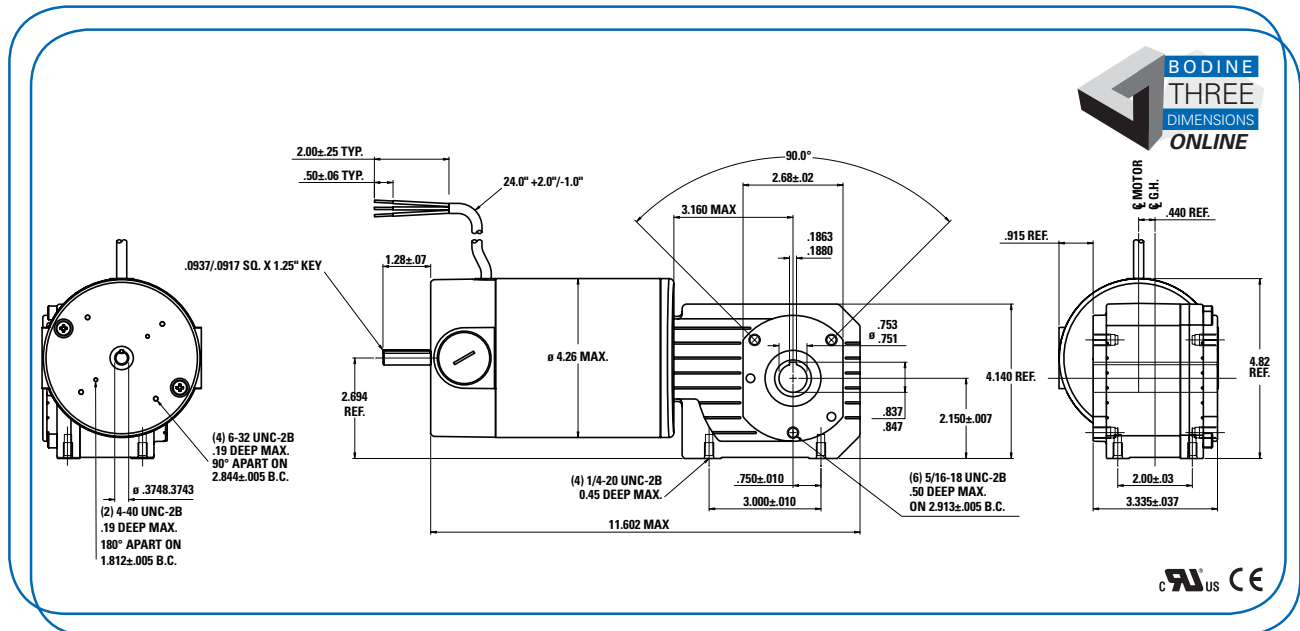

# INTEGRAmotor™ Hollow Shaft BLDC Gearmotors

Up to 37 lb-in. continuous

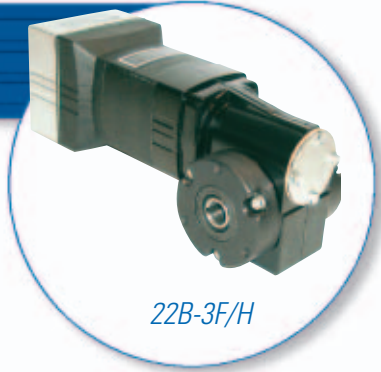

22B-3F/H



## Standard Features

- Integral control simplifies installation, minimizes EMI, and reduces wiring cost.
- Integral gear reducer increases torque and reduces speed.
- Higher gear ratios provide self-locking to hold load in place.
- Output torque ratings chosen for long, reliable life.
- Industrial lip type seals on motor and output shafts.
- Ball bearing on output shaft for increased radial load capacity and long life.
- Permanently lubricated gearing utilizing semi-fluid grease for long life and flexible mounting positions.
- Bronze gear for high shock load capability. Hardened and ground worm gear for high strength, long life, and quiet operation.
- Small size takes up minimal space.
- cURus, CE

## Application Information

- Gearmotors can be mounted via four tapped holes in bottom of the gearhead, or via three tapped holes on the left or right side of the gearhead.

## NEW! PWM Input Models

The new type 22B/FV models combine a 24VDC Brushless DC Motor with a built-in, open loop, voltage mode PWM controller. They accept PWM input from an external motion or speed controller, and feature amplifier enable, direction input, dynamic braking, and a built-in, 256 PPR, 2-channel encoder. These models are designed to be used in applications that would typically require more costly stepper or high-end servo motors. **Please visit our website for detailed information on the new 22B/FV series.**

Motor Output			Control Input			Length XH (inch)	Weight (lbs.)	Product Type	Model Number <sup>1</sup>
Speed Range (rpm)	Torque (lb-in.)	Gear Ratio	HP	Volts (VDC)	Continuous Amps				
<b>22B/SR-3R (Analog Input, 0-5V)</b>									
3-42	37	60:1	1/8	24	6.0	8.79	5.4	22B4BEBL/SR-3F/H	N8865
5-62	37	40:1	1/8	24	6.0	8.79	5.4	22B4BEBL/SR-3F/H	N8866
10-125	35	20:1	1/8	24	6.0	8.79	5.4	22B4BEBL/SR-3F/H	N8867
20-250	22	10:1	1/8	24	6.0	8.79	5.4	22B4BEBL/SR-3F/H	N8868
40-500	11	5:1	1/8	24	6.0	8.79	5.4	22B4BEBL/SR-3F/H	N8869
<b>22B/FV-3R (Digital Input, PWM)</b>									
1.3-42	37	60:1	1/8	24	6.0	8.79	5.4	22B4BEBL/FV-3F/H	N8765
2-62	37	40:1	1/8	24	6.0	8.79	5.4	22B4BEBL/FV-3F/H	N8766
4-125	35	20:1	1/8	24	6.0	8.79	5.4	22B4BEBL/FV-3F/H	N8767
7.5-250	22	10:1	1/8	24	6.0	8.79	5.4	22B4BEBL/FV-3F/H	N8768
15-500	11	5:1	1/8	24	6.0	8.79	5.4	22B4BEBL/FV-3F/H	N8769

<sup>1</sup> NOTE: Model numbers shown in bold type are in stock. "N" model numbers require lead time and minimum quantities.

## 22B/SR-3F/H and 22BFV-3F/H Hollow Shaft Gearmotor

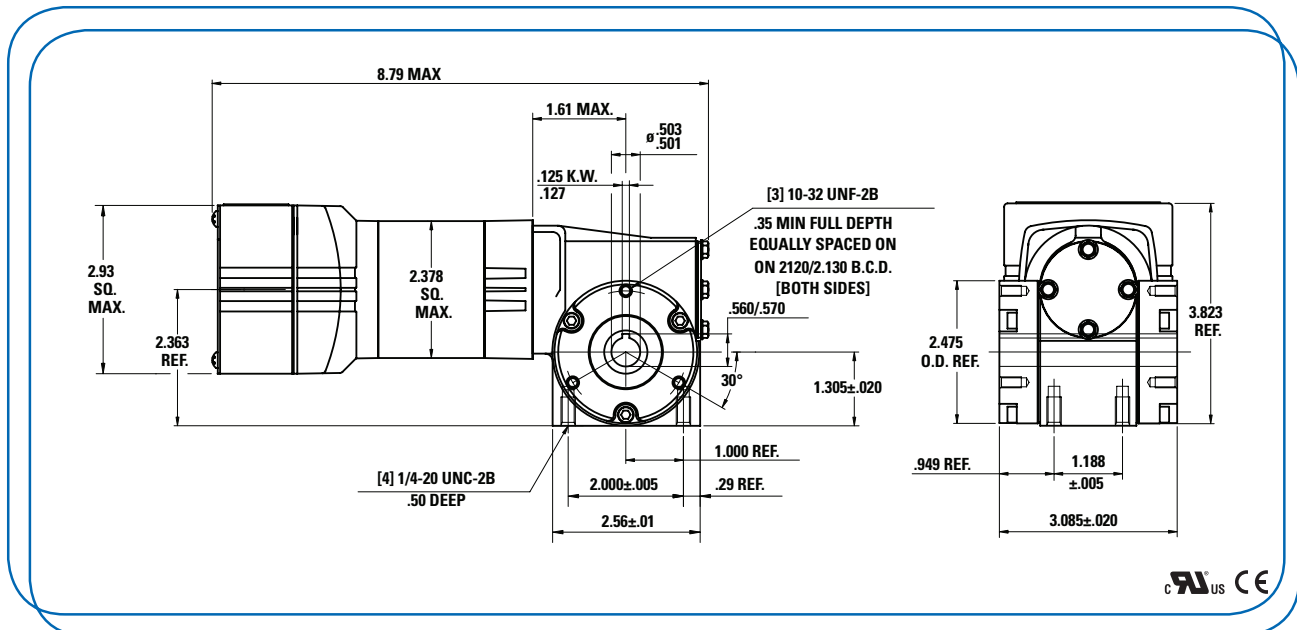



### Up to 1,000 lb-in.

**Bodine's type CG gearbox** is available with either AC or DC motors and has continuous torque ratings up to 1,000 lb-in in gear ratios up to 72:1.



### Low Cost 34B0 BLDC Motor and Gearmotor

for high-volume OEM applications. Matched-system BLDC controls available. Applications: Medical and laboratory equipment, blowers, and paper handling.

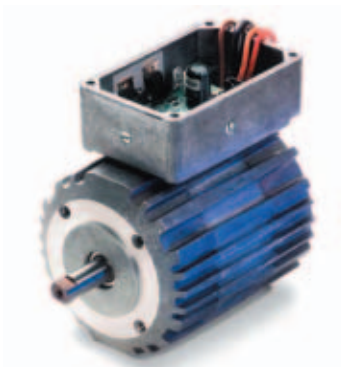

### Type 34B/FV BLDC motors and gearmotors with built-in custom speed controls.

Easy operation and connections, PWM speed signal, 24-36 VDC, 5 VDC logic signal, and tach pulse output.

# Bodine Custom Solutions

*Let us modify almost any AC, DC or Brushless DC product to perfectly fit your OEM application*

#### Controls:

When you use our built-to-order or stock controls, you'll get the best performance from your Bodine motors. A variety of enclosures, cables and interfaces are available for our AC, DC and Brushless products. For more information about our custom controls, see pages 22 and 102.

#### Cables

Choose from specially designed cables, connectors, and terminals, as well as custom terminal boxes, watertight strain relieves (PG fittings), and color-coded or labeled motor leads.

#### Add-On Options

Brakes and encoders mount to the end-shield. Or for economical 30PPR feedback we will supply internal encoders. Depending on the duty cycle, cooling fans can be added or omitted from most designs. And who says it must be black? Almost all Bodine products can be supplied either unpainted or with custom paint. We also offer special nameplates with your logo or part numbers.

#### Windings

Bodine stocks motors and gearmotors with all the typical voltage and frequency ratings for North American and International markets. Other ratings include inverter duty, intermittent duty, dual voltage, and dual frequency ratings with voltages ranging from 12VDC to 575VAC. We also offer custom winding designs for OEM application requirements and thermal overload protectors with manual and automatic reset.

#### Rotor/Armature

We offer an array of specially balanced, high-speed rotors and armatures and high-grade ball bearings. Ask about special bearings for high radial and axial load requirements.



For over 100 years of developing and designing motion control solutions, we not only know how to engineer an infinite variety of designs but very well may be tooled to build it.

If you get us involved early in the design or re-design process, we'll assist you in defining your requirements. We'll design a high value added, yet affordable, product specifically to meet your exact needs.

#### Mounting

Custom flange-, foot-, or base-mount designs are available. All motor and gearmotor designs can be provided with metric shafts, metric mounting holes and other metric features (terminal blocks, cables, nameplates, etc).

#### Gearing

Choose from a large selection of gears and gear ratios. Bodine gears provide high torque, quiet operation and long life. And because we make your prototypes in-house, you'll see your designs faster.

#### Gearboxes

Our parallel shaft or right angle, leak-free, integral, unvented gearhousings provide highest torque and the smallest possible package. Wide temperature-range synthetic lubricants are available, as are custom-placed vent-holes for non-standard mounting positions. We will even customize the gearhousing for high-volume OEM applications.

#### Output Shaft

Choose the material, the shape, the length and the diameter... Bodine driveshafts can be made just about any way you want. Here are just some of the options: steel, stainless steel, hardened, or fatigue proof materials; flats, slots, keyways, hex, double flats, cross-holes, retaining rings, and center holes. Many built-to-order hollow shafts, right-angle gearhead designs are available.

#### Seals

Tough environments demand tough seals. Our products already meet the highest leak protection requirements in the industry. Most Bodine gearheads are built with double helix, lip-type seals on motor and drive shafts and hardened seal journals for zero leakage. But if you demand even more protection, call us. We'll build it.

## Built-in Encoders

Encoders inside motors are protected from harsh environments and don't take up additional space. The magnetic encoders are powered by 4.5 – 12 volts and are available with one or two hall sensor output signals in resolutions of 2, 4, 8, and 30 pulses/revolution. They work with a digital tachometer or other electronic device to measure speed, distance, and direction. Bodine offers these built-in encoders as a custom option in our DC and Brushless DC motors. OEM applications include commercial ovens, guided vehicles, metering equipment, door openers, conveyors, and mobility equipment.

INcodermotor

**NEW**  
FROM BODINE!



## Liqui-Duty™ Motors and Gearmotors

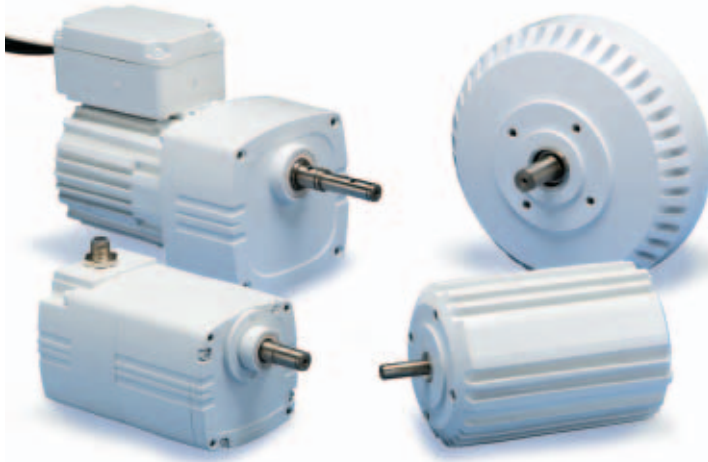

Our new built-to-order Liqui-Duty™ motors and gearmotors are custom engineered to meet unusual environmental challenges. While Liqui-Duty™ modifications vary from application to application, they include items such as: sealed bearings, specially sealed motor and gear housings, stainless steel shafts, special paint, cords, connectors, food-grade lubricants and many other customer-specified components. Bodine matched speed controls are also available.

## Custom Controls

Bodine understands that one size doesn't fit all. If our standard control enclosure doesn't suit an application, we design a custom one. We can put a different style switch, or knob, or fuse holder on the panel. We have created custom screen printed graphics. With our in-house electronics engineering capability, we can even create custom printed circuit boards for different voltage levels, or speed ranges, or higher output power. And we can tailor analog or digital interfaces to make our controls compatible with other devices.





# AC Products

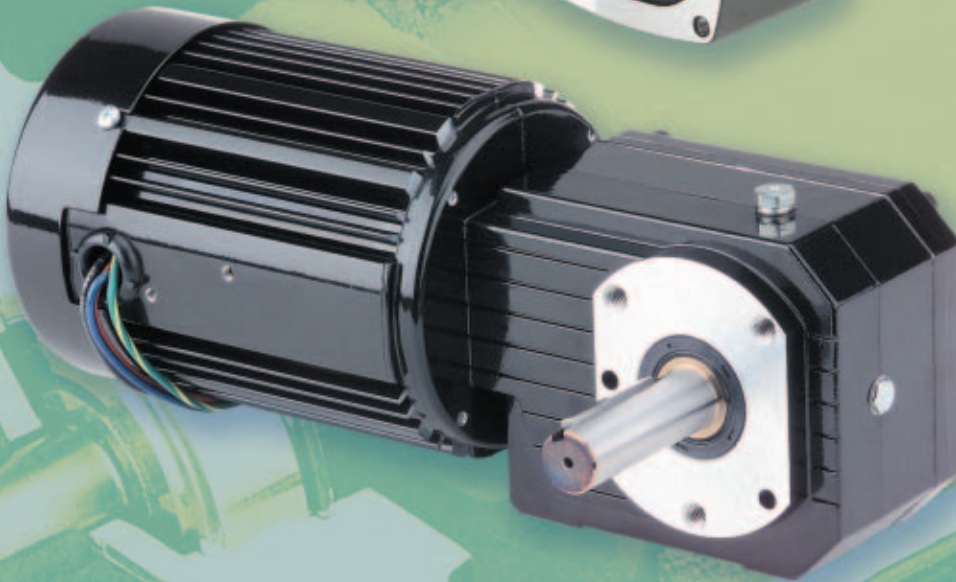

- Variable speed, inverter duty, three-phase motors and gearmotors with matched AC controls
- Permanent split capacitor motors are reliable, easy to install and ideal for fixed speed applications
- The best solution for continuous duty operation
- Torque motors for tensioning and holding



Bodine Electric’s extensive line of stock 3-phase, inverter duty, induction motors and gearmotors was designed with your application needs in mind. Bodine offers the widest selection of inverter duty, fractional horsepower (FHP) motors and gearmotors in the industry.

For over 100 years, optimized performance and highest output per frame size have been top priorities for the Bodine Electric design engineering team. The compact designs of our integral gearmotors can meet most of your tightest space requirements. The Bodine “Total System Approach” offers you superior motor and gearmotor products that are matched to reliable, high-performance inverter drives. Pacesetter™ inverter duty motors are reliable and cost effective alternatives to DC motor and control systems. They are more efficient and compact and don’t require time-consuming brush replacement or brush dust clean-up maintenance.

**PRODUCT FEATURES:**

- Quinsulation™, 5-stage insulation system designed to meet NEMA MG 1-1993, Section IV, Part 31
- 230VAC, 60 Hz, 3-phase and/or 230/460VAC, 60Hz, 3-phase for operation with a wide range of inverter products
- Inverter-Grade magnet wire and Class F insulation system for increased protection against spikes and corona damage caused by the inverter
- Optimized motor and gearhead combinations for maximum output power in the smallest package
- UL recognized for construction, CSA certified, and in compliance with the Low Voltage Directive “CE”

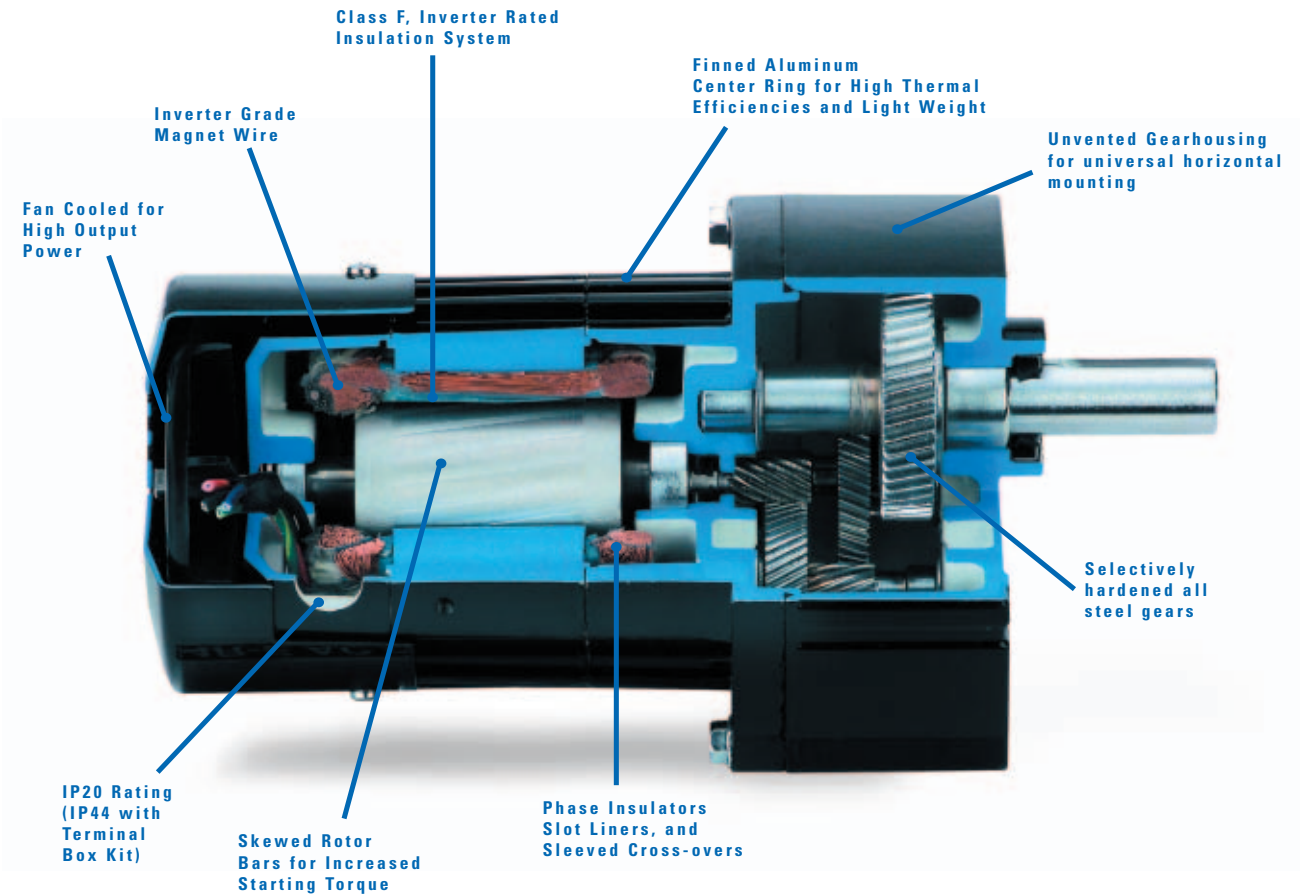

# Pacesetter AC Inverter Duty Motor

1/25 - 1/17 HP



30R Motor

## Inverter Duty Features

- Quintsulation™, 5-stage insulation system designed to meet NEMA MG 1-1993, Section IV, Part 31
- 230VAC, 60 Hz, 3-phase for operation with a wide range of inverter products
- Inverter-Grade magnet wire and Class F insulation system for increased protection against spikes and corona damage caused by the inverter
- UL recognized for construction, CSA certified, and in compliance with the Low Voltage Directive "CE"

## Standard Features

- Totally enclosed, non-ventilated IP-20 rating
- Class F insulation system for long life
- Aluminum endshields for high thermal efficiency and light weight
- Permanently lubricated, noise tested ball bearings
- Locked bearing design minimizes shaft endplay

## Application Information

- See page 64 for connection diagram
- Face mounting is standard

## Optional Accessories

- Die cast terminal box kit model 5982 achieves IP-44 rating, see page 62
- "L" bracket kit model 5968 permits base, ceiling, and sidewall mounting, see page 62

## Matching Controls

- Bodine stocks a full line of speed controls for Pacesetter motors. See pages 38-42



Fixed Speed Ratings				Variable Speed (SOA) Ratings <sup>2</sup>						XH (inch)	Wt. (lbs.)	Connection Diagram	Order Information	
Speed (rpm)	Torque (oz-in.)	Motor HP	V	Speed Range (rpm)	Frequ. Range (Hz)	Torque Type	Torque @						Product Type	Model No. <sup>1</sup>
							10 Hz (oz-in.)	60 Hz (oz-in.)	140 Hz (oz-in.)					
<b>Three-Phase, Inverter Duty, Non-synchronous Motor (TENV)</b>														
1700	24	1/25	230	220-3150	10-140	variable	20	56	27	3.7	4.5	074 10007	30R2BEPP	N2200
1700	35	1/17	230	133-3240	10-140	variable	45	66	35	4.2	6.2	074 10007	30R4BEPP	<b>2201</b>

<sup>1</sup> NOTE: Model numbers shown in bold type are in stock. "N" model numbers require lead time and minimum quantities.

<sup>2</sup> SOA: Contact the factory for detailed speed/torque information (Safe Operating Area). See page 37.

## 30R Motor

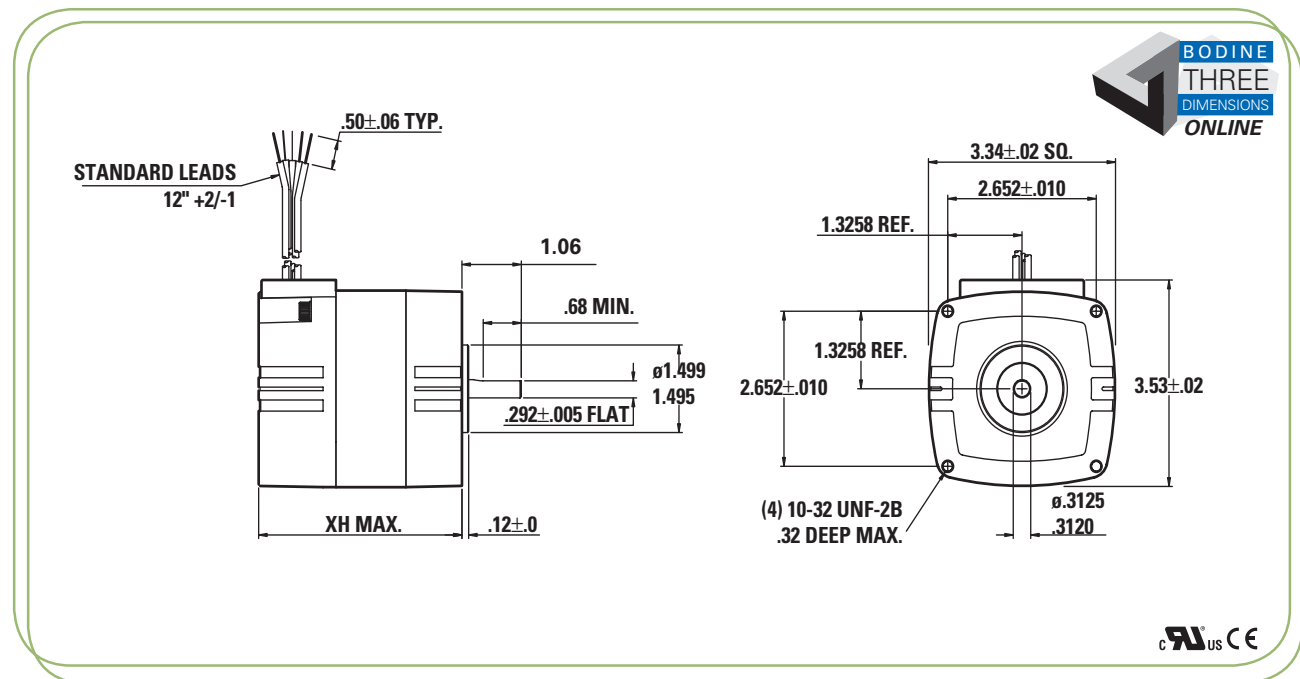

MADE IN U.S.A.

# Pacesetter AC Inverter Duty Motor

1/8 - 1/4 HP



34R Motor

### Inverter Duty Features

- Quinsulation™, 5-stage insulation system designed to meet NEMA MG 1-1993, Section IV, Part 31
- 230VAC, 60 Hz, 3-phase for operation with a wide range of inverter products
- Inverter-Grade magnet wire and Class F insulation system for increased protection against spikes and corona damage caused by the inverter
- UL recognized for construction, CSA certified, and in compliance with the Low Voltage Directive "CE"

### Standard Features

- Totally enclosed IP-20 rating
- Fan cooled for high output power
- Aluminum center ring and endshields for high thermal efficiency and light weight
- Permanently lubricated, noise tested ball bearings
- Locked bearing design minimizes shaft endplay

### Application Information

- See page 64 for connection diagram
- Face mounting is standard
- Dual voltage (230/460) models are available. These models require lead time and minimum quantities.

### Optional Accessories

- Die cast terminal box kit model 0984, 1984 achieves IP-44 rating, see page 62
- "L" bracket kit model 0979 permits base, ceiling, and sidewall mounting, see page 62
- Base kit model 0994 available, see page 62

### Matching Controls

- Bodine stocks a full line of speed controls for Pacesetter motors. See pages 38-42



Fixed Speed Ratings				Variable Speed (SOA) Ratings <sup>1</sup>						XH (inch)	Wt. (lbs.)	Connection Diagram	Order Information	
Speed (rpm)	Torque (oz-in.)	Motor HP	V	Speed Range (rpm)	Frequ. Range (Hz)	Torque Type	Torque @						Product Type	Model No.
							10 Hz (oz-in.)	60 Hz (oz-in.)	Max Hz (oz-in.)					
<b>Three-Phase, Inverter Duty, Non-synchronous Motor (TEFC)</b>														
1700	148	1/4	230	120-3650	10-140	variable	120	247	90	6.7	9	074 10007	34R6BFPP	2295
<b>Three-Phase, Inverter Duty, Synchronous Motor (TEFC)</b>														
1800	70	1/8	230	300-2400	10-80	variable	54	103	48	6.7	9	074 10007	34R6BFYP	2299

<sup>1</sup> SOA: Contact the factory for detailed speed/torque information (Safe Operating Area). See page 37.

## 34R Motor

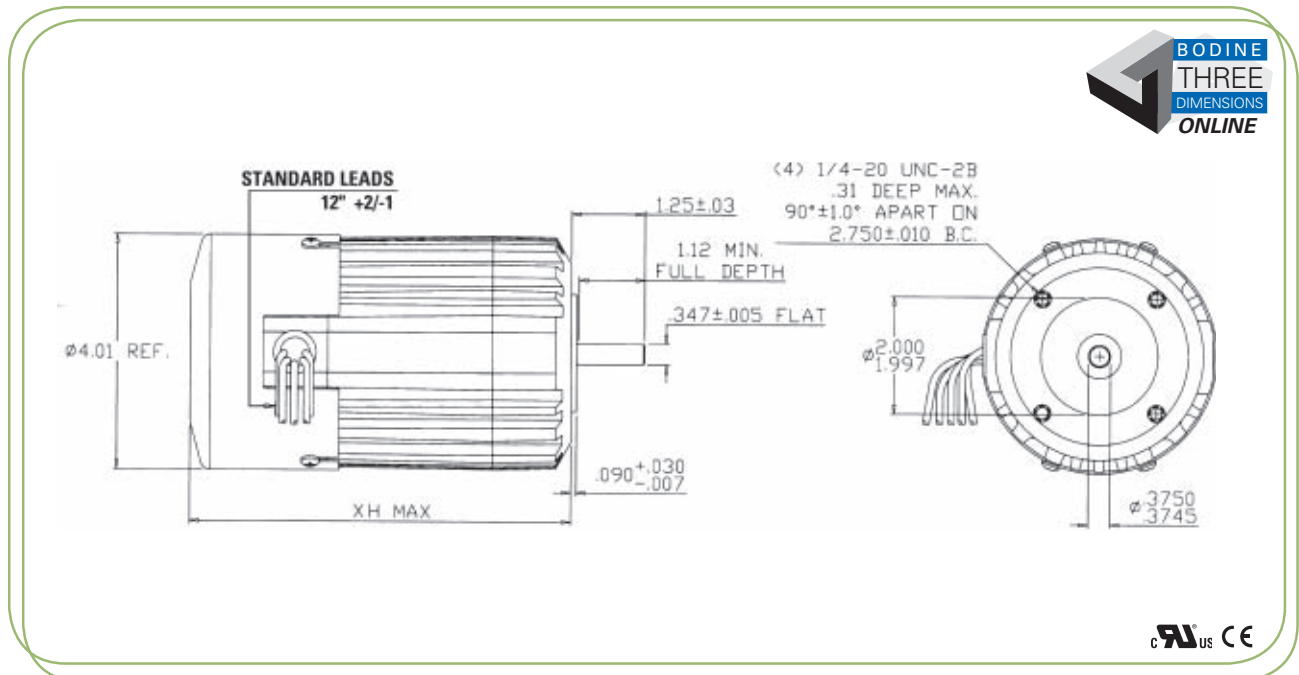

# Pacesetter AC Inverter Duty Motor

## 3/8 HP



### Inverter Duty Features

- Quintsulation™, 5-stage insulation system designed to meet NEMA MG 1-1993, Section IV, Part 31
- 230VAC, 60 Hz, 3-phase for operation with a wide range of inverter products
- Inverter-Grade magnet wire and Class F insulation system for increased protection against spikes and corona damage caused by the inverter
- UL recognized for construction, CSA certified, and in compliance with the Low Voltage Directive "CE"

### Standard Features

- Totally enclosed IP-20 rating
- Fan cooled for high output power
- Aluminum center ring and endshields for high thermal efficiency and light weight
- Permanently lubricated, noise tested ball bearings
- Locked bearing design minimizes shaft endplay

### Application Information

- See page 64 for connection diagram
- Base mounting or NEMA C face mounting is standard
- For lower cost, high volume applications, see 44C motors on page 18
- Dual voltage (230/460) models are also available. These models require lead time and minimum quantities.

### Optional Accessories

- Die cast terminal box kit model 0984,1984 achieves IP-44 rating, see page 62
- Steel terminal box kit model 0982 shown on page 62

### Matching Controls

- Bodine stocks a full line of speed controls for Pacesetter motors. See pages 38-42



Fixed Speed Ratings				Variable Speed (SOA) Ratings <sup>2</sup>						XH (inch)	Wt. (lbs.)	Connection Diagram	Order Information	
Speed (rpm)	Torque (oz-in.)	Motor HP	V	Speed Range (rpm)	Frequ. Range (Hz)	Torque Type	Torque @						Product Type	Model No. <sup>1</sup>
							10 Hz (oz-in.)	60 Hz (oz-in.)	140 Hz (oz-in.)					
<b>Three-Phase, Inverter Duty, Non-synchronous Motor (TEFC), Base Mount</b>														
1700	222	3/8	230	177-3500	10-140	variable	170	281	137	7.2	13	074 10007	42R6BFPP	<b>2235</b>
<b>Three-Phase, Inverter Duty, Non-synchronous Motor (TEFC), Face Mount</b>														
1700	222	3/8	230	177-3500	10-140	variable	170	281	137	7.2	13	074 10007	42R6BFPP	N2234

<sup>1</sup> NOTE: Model numbers shown in bold type are in stock. "N" model numbers require lead time and minimum quantities.

<sup>2</sup> SOA: Contact the factory for detailed speed/torque information (Safe Operating Area). See page 37.



NEMA C FACE MOUNT

42R Motor, Base Mount For NEMA C Face Mount dimensions, see page 49

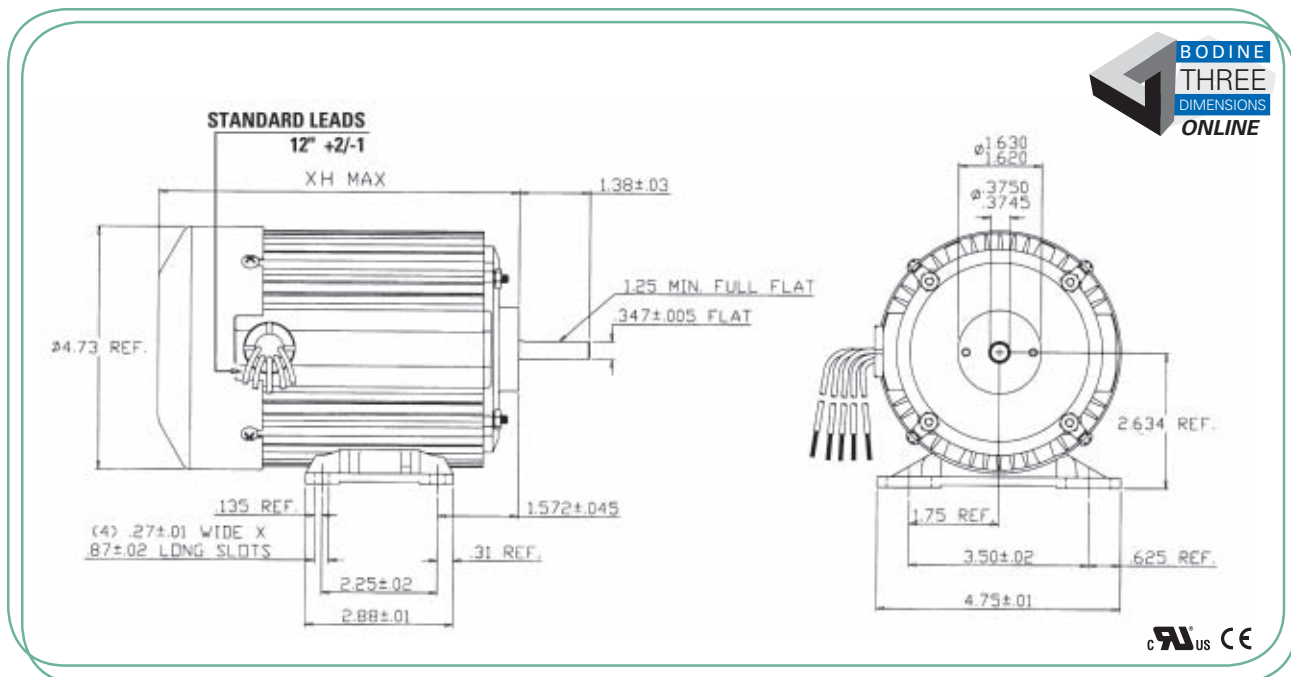

MADE IN U.S.A.

# Pacesetter AC Inverter Duty Motor

1/3 - 3/4 HP



48R Motor

### Inverter Duty Features

- Quinsulation™, 5-stage insulation system designed to meet NEMA MG 1-1993, Section IV, Part 31
- 230/460VAC, 60 Hz, 3-phase for operation with a wide range of inverter products
- Inverter-Grade magnet wire and Class F insulation system for increased protection against spikes and corona damage caused by the inverter
- UL recognized for construction, CSA certified, and in compliance with the Low Voltage Directive "CE"

### Standard Features

- Totally enclosed IP-20 rating
- Fan cooled for high output power
- Aluminum center ring and endshields for high thermal efficiency and light weight
- Permanently lubricated, noise tested ball bearings
- Locked bearing design minimizes shaft endplay

### Application Information

- See page 64 for connection diagram
- Base mounting and NEMA 56C face are standard

### Optional Accessories

- Die cast terminal box kit model 0984,1984 achieves IP-44 rating, see page 62
- Steel terminal box kit model 0982 shown on page 62

### Matching Controls

- Bodine stocks a full line of speed controls for Pacesetter motors. See pages 38-42



Fixed Speed Ratings				Variable Speed (SOA) Ratings <sup>1</sup>							XH (inch)	Wt. (lbs.)	Connection Diagram	Order Information	
Speed (rpm)	Torque (oz-in.)	Motor HP	V	Speed Range (rpm)	Frequ. Range (Hz)	Torque Type	Torque @			Product Type				Model No.	
							10 Hz (oz-in.)	60 Hz (oz-in.)	Max Hz (oz-in.)						
<b>Three-Phase, Inverter Duty, Non-synchronous Motor (TEFC)</b>															
1700	445	3/4	230/460	160-3600	10-140	variable	412	675	220	7.8	20.5	074 10012	48R6BFPP	2240	
<b>Three-Phase, Inverter Duty, Synchronous Motor (TEFC)</b>															
1800	185	1/3	230/460	300-2400	10-80	variable	220	262	125	7.31	17	074 10012	48R5BFYP	2244	

<sup>1</sup> SOA: Contact the factory for detailed speed/torque information (Safe Operating Area).

### 48R Motor

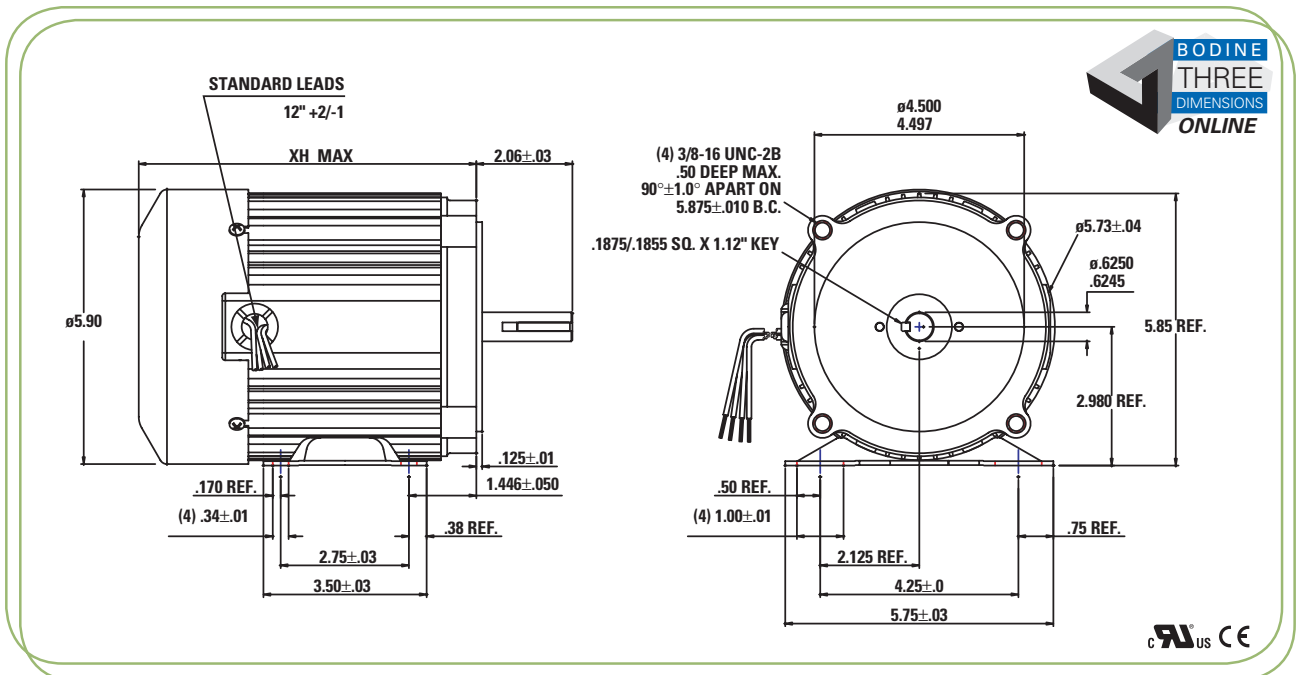

# Pacesetter Parallel Shaft AC Inverter Duty Gearmotor

Up to 40 lb-in. continuous



30R-D

## Inverter Duty Features

- Quinsulation™, 5-stage insulation system designed to meet NEMA MG 1-1993, Section IV, Part 31
- 230VAC, 60 Hz, 3-phase for operation with a wide range of inverter products
- Inverter-Grade magnet wire and Class F insulation system for increased protection against spikes and corona damage caused by the inverter
- UL recognized for construction, CSA certified, and in compliance with the Low Voltage Directive "CE"

## Standard Features

- Totally Enclosed, Non-Ventilated IP-20 rating
- Class F insulation system
- Aluminum endshields for high thermal efficiency and light weight
- Unvented gearhousing for universal horizontal mounting
- Industrial lip type seals on motor and output shafts
- Needle bearings on output shaft for increased radial load capacity and long life

- All steel gears
- Permanently lubricated with high-performance lubricant
- Helical pinion accurately cut on motor shaft for maximum strength and minimum noise

## Application Information

- See page 64 for connection diagram
- Face mounting is standard

## Optional Accessories

- Die cast terminal box kit model 5982, see page 62
- "L" bracket kit model 5968 permits base, ceiling and sidewall mounting, see page 62

## Matching Controls

- Bodine stocks a full line of speed controls for Pacesetter motors. See pages 38-42



Fixed Speed Ratings					Variable Speed (SOA) Ratings <sup>2</sup>						XH (inch)	Wt. (lbs.)	Connection Diagram	Order Information	
Speed (rpm)	Torque (lb-in.)	Motor HP	V	Gear Ratio	Speed Range (rpm)	Frequ. Range (Hz)	Torque Type	Torque @						Product Type	Model No. <sup>1</sup>
								10 Hz (lb-in.)	60 Hz (lb-in.)	90 Hz (lb-in.)					
<b>Three-Phase, Inverter Duty, Non-synchronous (TENV)</b>															
9	40	1/25	230	180	1.2-11.65	10-90	constant	40	40	40	5.5	6.3	074 10007	30R2BEPP-D4	<b>2210</b>
19	40	1/25	230	90	2.5-23	10-90	constant	40	40	40	5.5	6.3	074 10007	30R2BEPP-D4	N2212
28	40	1/25	230	60	3.7-35	10-90	constant	40	40	40	5.5	6.3	074 10007	30R2BEPP-D3	N2214
142	19	1/17	230	12	19-175	10-90	constant	19	19	19	6	7.5	074 10007	30R4BEPP-D3	<b>2216</b>

<sup>1</sup> NOTE: Model numbers shown in bold type are in stock. "N" model numbers require lead time and minimum quantities.

<sup>2</sup> SOA: Contact the factory for detailed speed/torque information (Safe Operating Area). See page 37.

## 30R-D Gearmotor

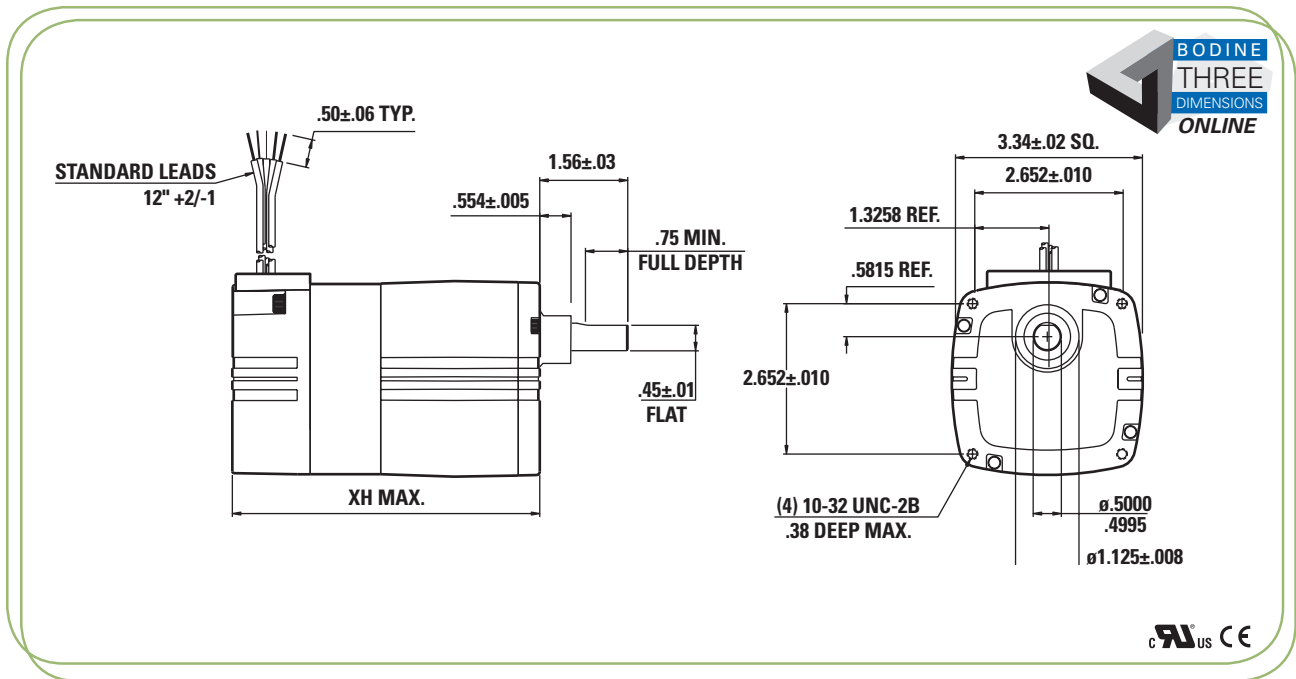

New e-TORQ™ INTEGRAmotor™ Hollow Shaft Custom Pacesetter™ Inverter Duty AC Induction Permanent Magnet DC Brushless DC Index

# Pacesetter Parallel Shaft AC Inverter Duty Gearmotor

Up to 120 lb-in. continuous



34R-Z



### Inverter Duty Features

- Quinsulation™, 5-stage insulation system designed to meet NEMA MG 1-1993, Section IV, Part 31
- 230VAC, 60 Hz, 3-phase for operation with a wide range of inverter products
- Inverter-Grade magnet wire and Class F insulation system for increased protection against spikes and corona damage caused by the inverter
- UL recognized for construction, CSA certified, and in compliance with the Low Voltage Directive "CE"

### Standard Features

- Totally enclosed IP-20 rating
- Aluminum center ring and endshields for high thermal efficiency and light weight
- Unvented gearhousing for universal horizontal mounting
- Industrial lip type seals on motor and output shafts
- Needle bearings on output shaft for increased radial load capacity and long life
- Permanently lubricated with high-performance lubricant

### All steel gears

- Helical pinion accurately cut on motor shaft for maximum strength and minimum noise

### Application Information

- See page 64 for connection diagram
- Face mounting is standard

### Optional Accessories

- Die cast terminal box kit model 0984,1984 achieves IP-44 rating, see page 62
- "L" bracket kit model 0980 permits base, ceiling, and sidewall mounting, see page 62

### Matching Controls

- Bodine stocks a full line of speed controls for Pacesetter motors. See pages 38-42

Fixed Speed Ratings					Variable Speed (SOA) Ratings <sup>2</sup>						XH (inch)	Wt. (lbs.)	Connection Diagram	Order Information	
Speed (rpm)	Torque (lb-in.)	Motor HP	V	Gear Ratio	Speed Range (rpm)	Frequ. Range (Hz)	Torque Type	Torque @						Product Type	Model No. <sup>1</sup>
								10 Hz (lb-in.)	60 Hz (lb-in.)	90 Hz (lb-in.)					
<b>Three-Phase, Inverter Duty, Non-synchronous (TENV)</b>															
9	120	1/6	230	180	0.9-13	10-90	constant	120	120	120	8.4	10.5	074 10007	34R6BEPP-Z4	<b>2220</b>
19	120	1/6	230	90	1.8-26	10-90	constant	120	120	120	8.4	10.5	074 10007	34R6BEPP-Z4	N2222
28	120	1/6	230	60	2.8-39	10-90	constant	120	120	120	8.4	10.5	074 10007	34R6BEPP-Z3	N2224
57	96	1/6	230	30	5.5-78	10-90	constant	96	96	96	8.4	10.5	074 10007	34R6BEPP-Z3	<b>2226</b>
94	39	1/6	230	18	16-43	10-90	constant	39	39	39	7.5	10.5	074 10007	34R6BEPP-Z2	N2227
283	21	1/6	230	6	28-391	10-90	constant	21	21	21	7.5	10.5	074 10007	34R6BEPP-Z2	N2228

<sup>1</sup> NOTE: Model numbers shown in bold type are in stock. "N" model numbers require lead time and minimum quantities.

<sup>2</sup> SOA: Contact the factory for detailed speed/torque information (Safe Operating Area). See page 37.

### 34R-Z Gearmotor

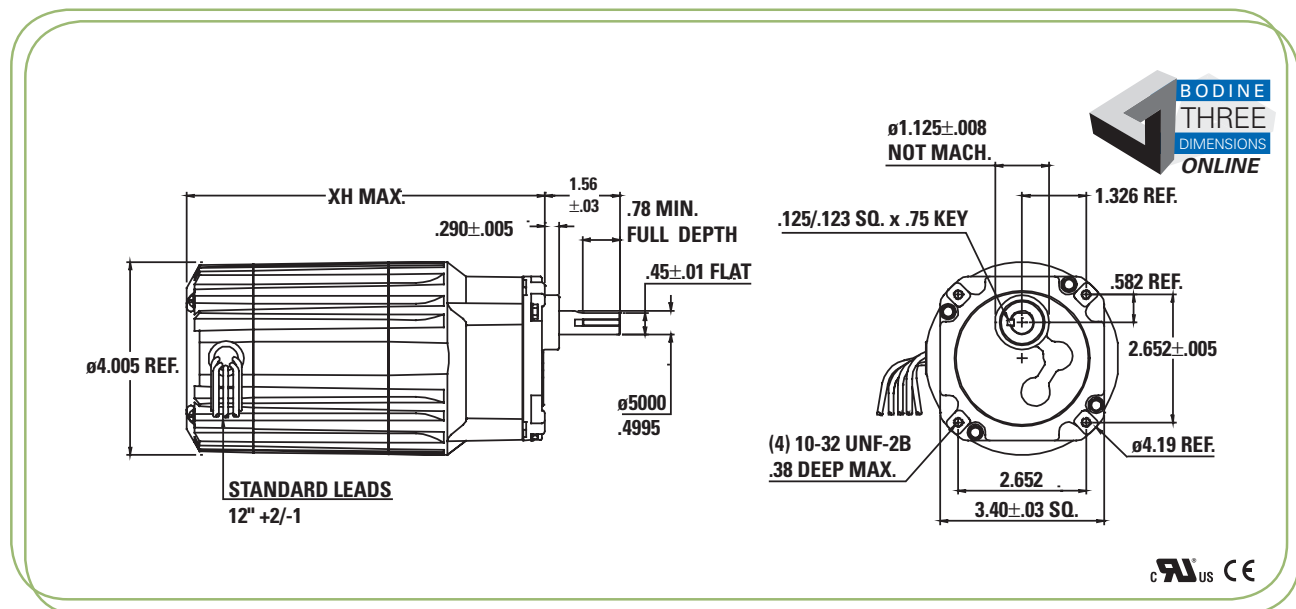



# Pacesetter Parallel Shaft AC Inverter Duty Gearmotor

Up to 341 lb-in. continuous

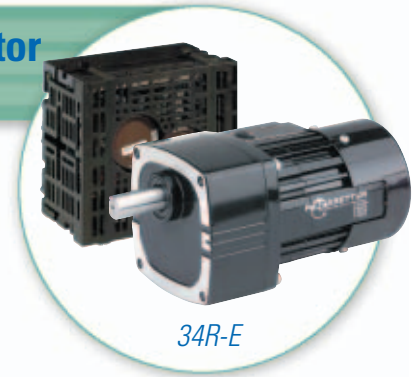

34R-E

## Inverter Duty Features

- Quinsulation™, 5-stage insulation system designed to meet NEMA MG 1-1993, Section IV, Part 31
- 230VAC, 60 Hz, 3-phase for operation with a wide range of inverter products
- Inverter-Grade magnet wire and Class F insulation system for increased protection against spikes and corona damage caused by the inverter
- All new optimized motor and gearhead combinations for maximum output power in the smallest package
- UL recognized for construction, CSA certified, and in compliance with the Low Voltage Directive "CE"

## Standard Features

- Unvented gearhousing for universal horizontal mounting
- Permanently lubricated with high-performance lubricant
- All steel gearing

## Application Information

- See page 64 for connection diagram
- Face mounting is standard
- Dual voltage (230/460) models are also available. These models require lead time and minimum quantities.

## Optional Accessories

- Die cast terminal box kit model 0984,1984 achieves IP-44 rating, see page 62
- Stamped terminal box kit model 0982 see page 62
- "L" bracket kit model 0969 permits base, ceiling, and sidewall mounting, see page 62
- Adapter plate kit model 0995 provides for drop-in replacement of competitive gearmotors, see page 62

## Matching Controls

- Bodine stocks a full line of speed controls for Pacesetter motors. See pages 38-42



Fixed Speed Ratings					Variable Speed (SOA) Ratings <sup>2</sup>						XH (inch)	Wt. (lbs.)	Connection Diagram	Order Information	
Speed (rpm)	Torque (lb-in.)	Motor HP	V	Gear Ratio	Speed Range (rpm)	Frequ. Range (Hz)	Torque Type	Torque @						Product Type	Model No. <sup>1</sup>
<b>Three-Phase, Inverter Duty, Non-synchronous (TEFC)</b>															
9.4	341	1/6	230	180	0.7-12	10-90	constant	341	341	341	8.8	11	074 10007	34R4BFPP-E4	<b>2250</b>
19	250	1/6	230	90	1.3-24	10-90	constant	250	250	250	8.8	11	074 10007	34R4BFPP-E4	<b>2251</b>
28	270	1/6	230	60	2.0-36	10-90	variable	250	270	270	8.8	11	074 10007	34R4BFPP-E3	<b>2252</b>
57	135	1/6	230	30	4.0-73	10-90	variable	124	135	135	8.8	11	074 10007	34R4BFPP-E3	N2253
170	45	1/6	230	10	12-218	10-90	variable	42	45	45	8.8	11	074 10007	34R4BFPP-E2	N2254
340	25	1/6	230	5	24-436	10-90	variable	22	25	25	8.8	11	074 10007	34R4BFPP-E1	N2255

<sup>1</sup> NOTE: Model numbers shown in bold type are in stock. "N" model numbers require lead time and minimum quantities.

<sup>2</sup> SOA: Contact the factory for detailed speed/torque information (Safe Operating Area). See page 37.

## 34R-E Gearmotor

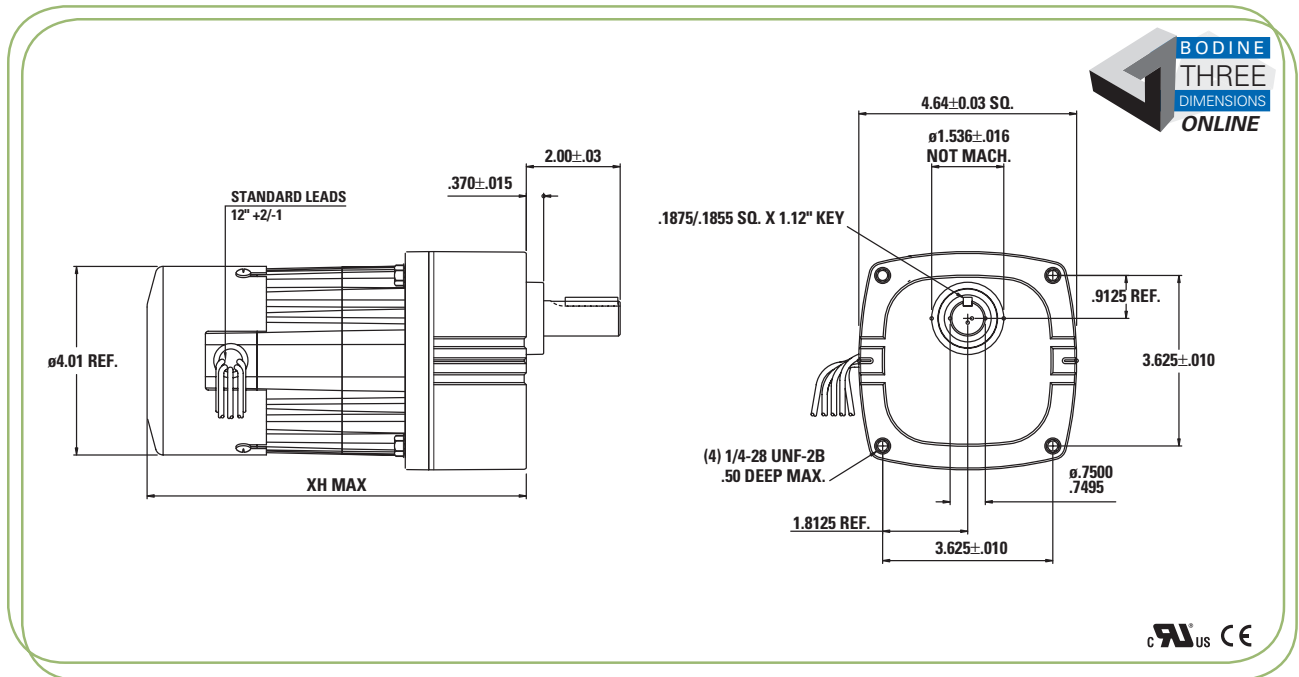

MADE IN U.S.A.

New e-TORQ™ INTEGRAMOTOR™ Hollow Shaft Custom Pacesetter™ Inverter Duty AC Induction Permanent Magnet DC Brushless DC Index



# Pacesetter Parallel Shaft AC Inverter Duty Gearmotor

Up to 250 lb-in. continuous

## Inverter Duty Features

- Quinsulation™, 5-stage insulation system designed to meet NEMA MG 1-1993, Section IV, Part 31
- 230VAC, 60 Hz, 3-phase for operation with a wide range of inverter products
- Inverter-Grade magnet wire and Class F insulation system for increased protection against spikes and corona damage caused by the inverter
- All new optimized motor and gearhead combinations for maximum output power in the smallest package
- UL recognized for construction, CSA certified, and in compliance with the Low Voltage Directive "CE"

## Standard Features

- Unvented gearhousing for universal horizontal mounting
- Industrial lip type seals on motor and output shafts
- Needle bearings throughout for increased radial load capacity and long life
- Permanently lubricated with high-performance lubricant
- Hardened helical gearing for quietness and high output to size ratio

## Application Information

- See page 64 for connection diagram
- Face mounting is standard
- Dual voltage (230/460) models are also available. These models require lead time and minimum quantities.

## Optional Accessories

- Die cast terminal box kit model 0984,1984 achieves IP-44 rating, see page 62
- Stamped terminal box kit model 0982 see page 62
- "L" bracket kit model 0969 permits base, ceiling, and sidewall mounting, see page 62
- Adapter plate kit model 0995 provides for drop-in replacement of competitive gearmotors, see page 62

## Matching Controls

- Bodine stocks a full line of speed controls for Pacemaker motors. See pages 38-42



Fixed Speed Ratings					Variable Speed (SOA) Ratings <sup>1</sup>						XH (inch)	Wt. (lbs.)	Connection Diagram	Order Information	
Speed (rpm)	Torque (lb-in.)	Motor HP	V	Gear Ratio	Speed Range (rpm)	Frequ. Range (Hz)	Torque Type	Torque @						Product Type	Model No.
								10 Hz (lb-in.)	60 Hz (lb-in.)	90 Hz (lb-in.)					
<b>Three-Phase, Inverter Duty, Non-synchronous (TEFC)</b>															
57	250	3/8	230	30	5.9-77	10-90	constant	250	250	250	9.58	16.5	074 10007	42R6BFPP-F3	2260
85	167	3/8	230	20	8.8-115	10-90	constant	167	167	167	9.58	16.5	074 10007	42R6BFPP-F3	2261
170	115	3/8	230	10	18-229	10-90	variable	92	115	115	9.58	16.5	074 10007	42R6BFPP-F2	2262
340	58	3/8	230	5	35-459	10-90	variable	48	58	58	9.58	16.5	074 10007	42R6BFPP-F1	2263

<sup>1</sup> SOA: Contact the factory for detailed speed/torque information (Safe Operating Area). See page 37.

## 42R-F Gearmotor

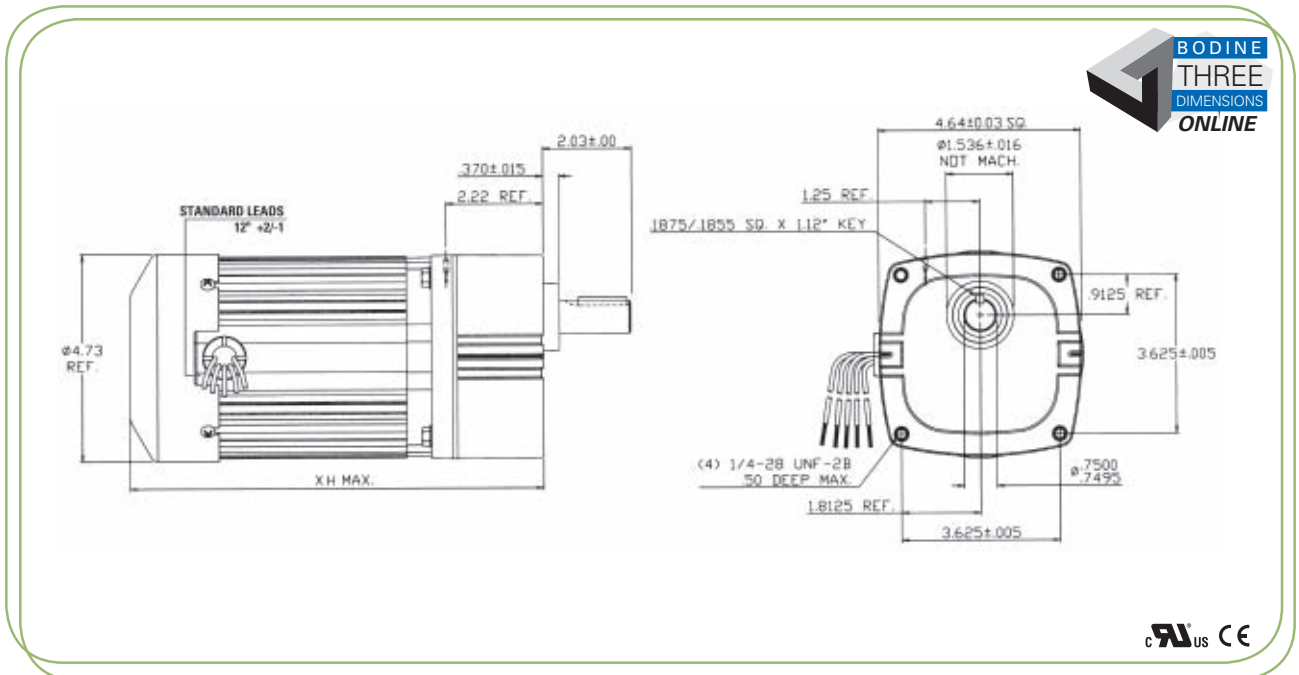

# Pacesetter Right Angle AC Inverter Duty Gearmotor

Up to 37 lb-in. continuous



30R-3N

## Inverter Duty Features

- Quinsulation™, 5-stage insulation system designed to meet NEMA MG 1-1993, Section IV, Part 31
- 230VAC, 60 Hz, 3-phase for operation with a wide range of inverter products
- Inverter-Grade magnet wire and Class F insulation system for increased protection against spikes and corona damage caused by the inverter
- All new optimized motor and gearhead combinations for maximum output power in the smallest package
- UL recognized for construction, CSA certified, and in compliance with the Low Voltage Directive "CE"

- Bronze gear for high shock load capability
- Hardened and ground worm for high strength and long life

## Application Information

- Mounting holes are on gearhousing
- See page 64 for connection diagram
- Hollow shaft configurations are available. See Web site for mounting and shaft details. These models require lead time and minimum quantities.

## Optional Accessories

- Baseplate kit model 0967, see page 62
- Die cast terminal box kit model 5982, see page 62

## Matching Controls

- Bodine stocks a full line of speed controls for Pacesetter motors. See pages 38-42

## Standard Features

- Industrial lip seals on motor and output shafts
- Needle bearings on output shaft for increased radial load capacity and long life
- Permanently lubricated with high-performance lubricant



Fixed Speed Ratings					Variable Speed (SOA) Ratings <sup>2</sup>						XH (inch)	Wt. (lbs.)	Connection Diagram	Order Information	
Speed (rpm)	Torque (lb-in.)	Motor HP	V	Gear Ratio	Speed Range (rpm)	Freq. Range (Hz)	Torque Type	Torque @						Product Type	Model No. <sup>1</sup>
								10 Hz (lb-in.)	60 Hz (lb-in.)	90 Hz (lb-in.)					
<b>Three-Phase, Inverter Duty, Non-synchronous (TENV)</b>															
28	37	1/17	230	60	2.2-36	10-90	constant	37	37	37	7.24	7.5	074 10007	<b>30R4BEPP-3N</b>	<b>N2290</b>
34	36	1/17	230	50	2.7-43	10-90	variable	33	37	37	7.24	7.5	074 10007	<b>30R4BEPP-3N</b>	<b>N2292</b>
43	37	1/17	230	40	3.3-54	10-90	constant	37	37	37	7.24	7.5	074 10007	<b>30R4BEPP-3N</b>	<b>N2293</b>
85	25	1/17	230	20	6.6-108	10-90	variable	24	36	36	7.24	7.5	074 10007	<b>30R4BEPP-3N</b>	<b>N2294</b>
170	14	1/17	230	10	13-216	10-90	variable	16	28	22	7.24	7.5	074 10007	<b>30R4BEPP-3N</b>	<b>N2296</b>
340	8	1/17	230	5	27-431	10-90	variable	9.0	15	12	7.24	7.5	074 10007	<b>30R4BEPP-3N</b>	<b>N2297</b>

<sup>1</sup> NOTE: Model numbers shown in bold type are in stock. "N" model numbers require lead time and minimum quantities.

<sup>2</sup> SOA: Contact the factory for detailed speed/torque information (Safe Operating Area). See page 37.

## 30R-3N Gearmotor

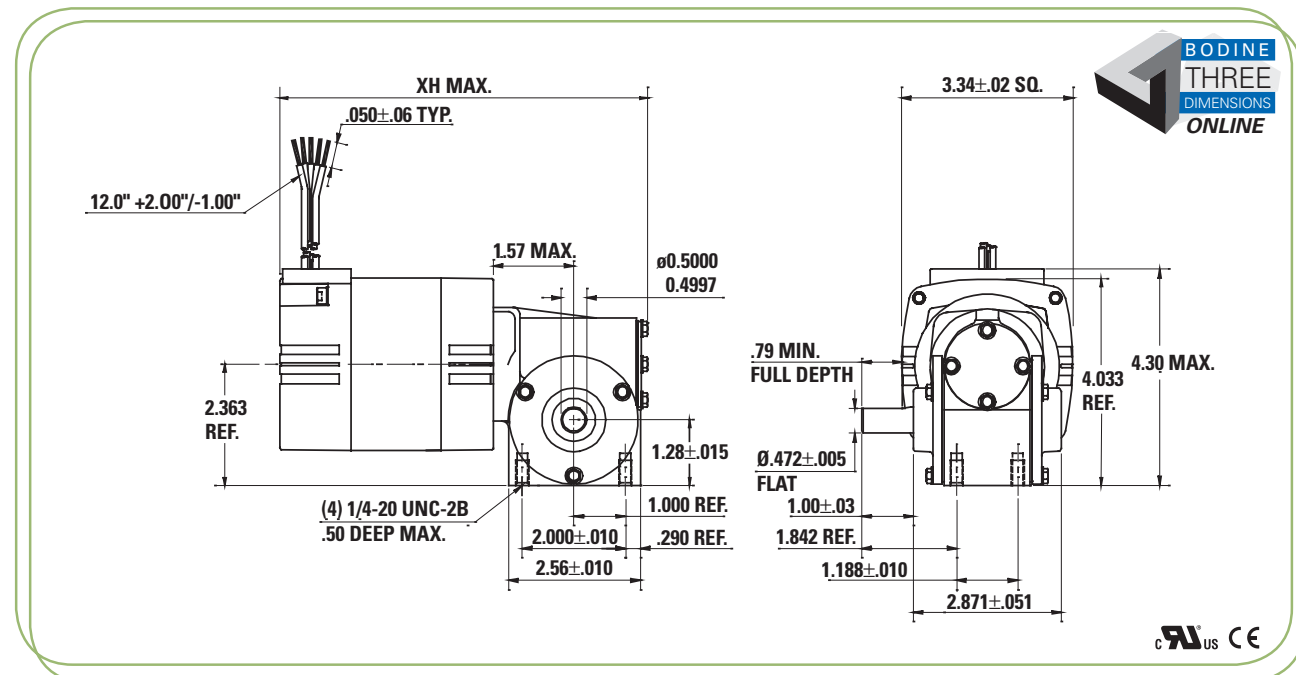

MADE IN U.S.A.



42R-5N

# Pacesetter Right Angle AC Inverter Duty Gearmotor

Up to 121 lb-in. continuous

### Inverter Duty Features

- Quinsulation™, 5-stage insulation system designed to meet NEMA MG 1-1993, Section IV, Part 31
- 230VAC, 60 Hz, 3-phase for operation with a wide range of inverter products
- Inverter-Grade magnet wire and Class F insulation system for increased protection against spikes and corona damage caused by the inverter
- All new optimized motor and gearhead combinations for maximum output power in the smallest package
- UL recognized for construction, CSA certified, and in compliance with the Low Voltage Directive "CE"

- Permanently lubricated with high-performance lubricant
- Bronze worm gear for high shock load capability
- Hardened and ground worm for strength and long life

### Application Information

- See page 64 for connection diagram
- Mounting feet are on the gearhead
- Hollow shaft configurations are available. See page 12 for mounting and shaft details. Some models require lead time and minimum quantities.
- Dual voltage (230/460) models are also available. These models require lead time and minimum quantities.



### Standard Features

- Totally enclosed IP-20 rating
- Fan cooled for high output power
- Aluminum center ring and endshields for high thermal efficiency and light weight
- Unvented gearhousing for universal horizontal mounting
- Industrial lip type seals on motor and output shafts
- Needle bearings throughout for increased radial load capacity and long life

### Optional Accessories

- Die cast terminal box kit model 0984,1984 achieves IP-44 rating, see page 62
- Stamped terminal box kit model 0982 shown on page 62

### Matching Controls

- Bodine stocks a full line of speed controls for Pacesetter motors. See pages 38-42

Fixed Speed Ratings					Variable Speed (SOA) Ratings <sup>2</sup>						XH (inch)	Wt. (lbs.)	Connection Diagram	Order Information	
Speed (rpm)	Torque (lb-in.)	Motor HP	V	Gear Ratio	Speed Range (rpm)	Frequ. Range (Hz)	Torque Type	Torque @						Product Type	Model No. <sup>1</sup>
								10 Hz (lb-in.)	60 Hz (lb-in.)	90 Hz (lb-in.)					
<b>Three-Phase, Inverter Duty, Non-synchronous (TEFC)</b>															
23	121	3/8	230	75	2.4-31	10-90	variable	121	121	116	10.75	17.5	074 10007	42R6BFPP-5N	<b>2270</b>
43	113	3/8	230	40	4.4-57	10-90	constant	109	109	109	10.75	17.5	074 10007	42R6BFPP-5N	<b>2271</b>
57	109	3/8	230	30	5.9-77	10-90	constant	104	104	104	10.75	17.5	074 10007	42R6BFPP-5N	N2275
85	103	3/8	230	20	8.9-115	10-90	constant	98	98	98	10.75	17.5	074 10007	42R6BFPP-5N	<b>2272</b>
170	101	3/8	230	10	18-229	10-90	variable	66	105	101	10.75	17.5	074 10007	42R6BFPP-5N	<b>2273</b>
340	54	3/8	230	5	35-458	10-90	variable	38	68	59	10.75	17.5	074 10007	42R6BFPP-5N	<b>2274</b>

<sup>1</sup> NOTE: Model numbers shown in bold type are in stock. "N" model numbers require lead time and minimum quantities.

<sup>2</sup> SOA: Contact the factory for detailed speed/torque information (Safe Operating Area).

### 42R-5N Gearmotor

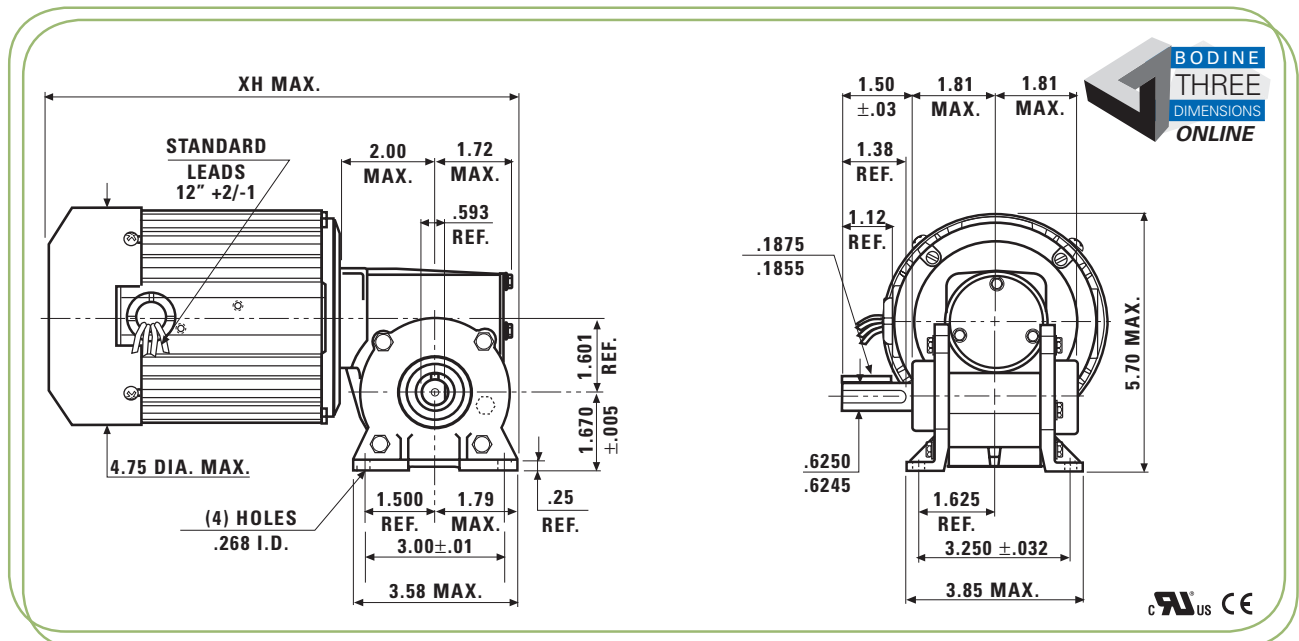

# Pacesetter Right Angle AC Inverter Duty Gearmotor

Up to 380 lb-in. continuous



42R-GB

## Inverter Duty Features

- Quinsulation™, 5-stage insulation system designed to meet NEMA MG 1-1993, Section IV, Part 31
- 230VAC, 60 Hz, 3-phase for operation with a wide range of inverter products
- Inverter-Grade magnet wire and Class F insulation system for increased protection against spikes and corona damage caused by the inverter
- All new optimized motor and gearhead combinations for maximum output power in the smallest package
- UL recognized for construction, CSA certified, and in compliance with the Low Voltage Directive "CE"

## Standard Features

- Totally enclosed IP-20 rating
- Fan cooled for high output power
- Aluminum center ring and endshields for high thermal efficiency and light weight
- Unvented gearhousing for universal horizontal mounting
- Industrial lip type seals on motor and output shafts
- Ball bearings throughout for increased radial load capacity and long life
- Permanently lubricated with high-performance lubricant

- Hardened helical output gearing for quietness and high output torque
- Bronze worm gear for high shock load capability
- Hardened and ground worm hobbled on the motor shaft for high strength and long life

## Application Information

- See page 64 for connection diagram
- Mounting is via four tapped holes under the gearhead or three tapped holes in the face of the gearhead
- Hollow shaft configurations are available. See page 13 for mounting and shaft details. Some models require lead time and minimum quantities.
- Dual voltage (230/460) models are also available. These models require lead time and minimum quantities.

## Optional Accessories

- Die cast terminal box kit model 0984,1984 achieves IP-44 rating see page 62
- Stamped terminal box kit model 0982 shown on page 62

## Matching Controls

- Bodine stocks a full line of speed controls for Pacesetter motors. See pages 38-42



Fixed Speed Ratings					Variable Speed (SOA) Ratings <sup>2</sup>						XH (inch)	Wt. (lbs.)	Connection Diagram	Order Information	
Speed (rpm)	Torque (lb-in.)	Motor HP	V	Gear Ratio	Speed Range (rpm)	Frequ. Range (Hz)	Torque Type	Torque @						Product Type	Model No. <sup>1</sup>
								10 Hz (lb-in.)	60 Hz (lb-in.)	90 Hz (lb-in.)					
<b>Three-Phase, Inverter Duty, Non-synchronous (TEFC)</b>															
6	380	3/8	230	280	0.6-8.2	10-90	constant	380	380	380	12.1	19.5	074 10007	42R6BFPP-GB	N2236
14	290	3/8	230	120	1.5-19	10-90	constant	290	290	290	12.1	19.5	074 10007	42R6BFPP-GB	<b>2237</b>
28	230	3/8	230	60	3.0-38	10-90	constant	230	230	230	12.1	19.5	074 10007	42R6BFPP-GB	N2238

<sup>1</sup> NOTE: Model numbers shown in bold type are in stock. "N" model numbers require lead time and minimum quantities.

<sup>2</sup> SOA: Contact the factory for detailed speed/torque information (Safe Operating Area). See page 37.

## 42R-GB Gearmotor

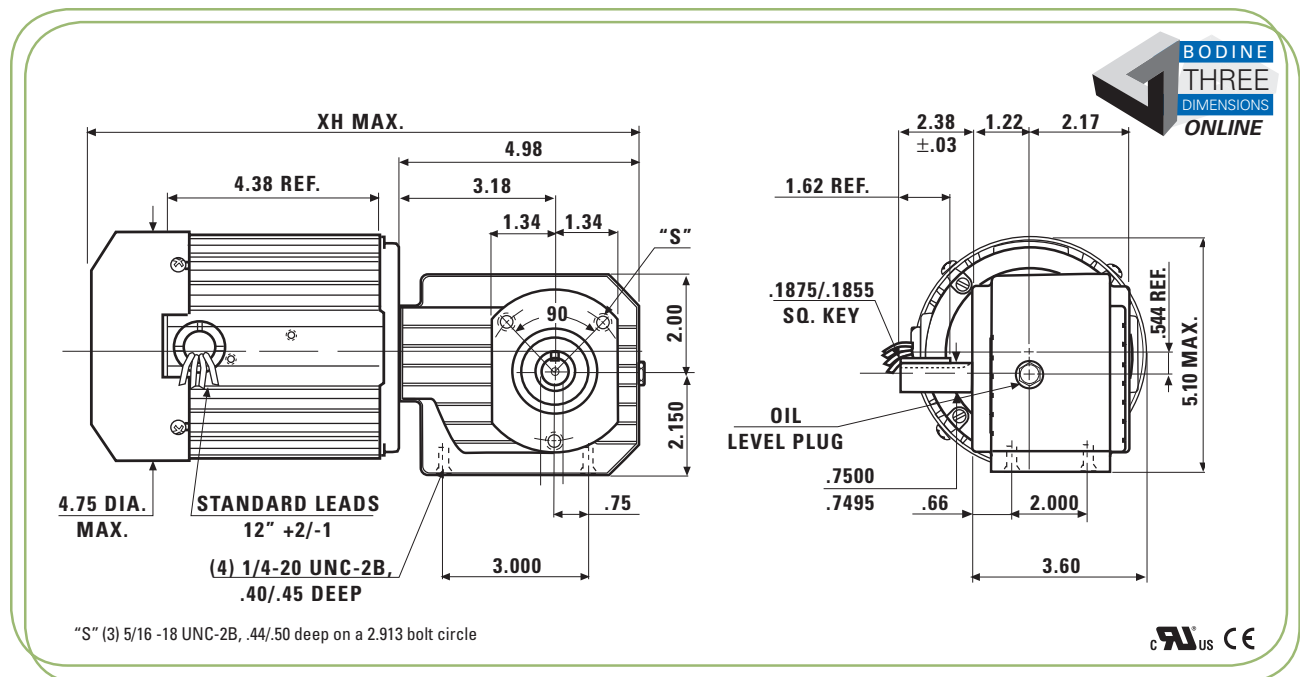

MADE IN U.S.A.



48R-5H

# Pacesetter Right Angle AC Inverter Duty Gearmotor

Up to 296 lb-in. continuous

### Inverter Duty Features

- Quinsulation™, 5-stage insulation system designed to meet NEMA MG 1-1993, Section IV, Part 31
- 230/460VAC, 60Hz, 3-phase for operation with a wide range of inverter products
- Inverter-Grade magnet wire and Class F insulation system for increased protection against spikes and corona damage caused by the inverter
- All new optimized motor and gearhead combinations for maximum output power in the smallest package
- UL recognized for construction, CSA certified, and in compliance with the Low Voltage Directive "CE"

- Permanently lubricated with high-performance lubricant
- Bronze gear for high shock load capability
- Hardened and ground worm for strength and long life

### Application Information

- See page 64 for connection diagram
- Mounting feet are located on gearhead

### Optional Accessories

- Die cast terminal box kit model 0984, 1984 achieves IP-44 rating, see page 62

### Matching Controls

- Bodine stocks a full line of speed controls for Pacesetter motors. See pages 38-42



### Standard Features

- Rugged gearhead designed for heavy continuous loads with ample strength for shock loads
- Industrial lip type seals on motor and output shaft
- Ball bearing on output shaft for high radial and axial load capacity

Fixed Speed Ratings					Variable Speed (SOA) Ratings <sup>2</sup>						XH (inch)	Wt. (lbs.)	Connection Diagram	Order Information	
Speed (rpm)	Torque (lb-in.)	Motor HP	V	Gear Ratio	Speed Range (rpm)	Frequ. Range (Hz)	Torque Type	Torque @						Product Type	Model No. <sup>1</sup>
								10 Hz (lb-in.)	60 Hz (lb-in.)	90 Hz (lb-in.)					
<b>Three-Phase, Inverter Duty, Non-synchronous (TEFC)</b>															
35	296	3/4	230/460	48	3.3-48	10-90	constant	272	272	272	13.4	40	074 10012	48R6BFPP-5H N2280	
47	285	3/4	230/460	36	4.4-63	10-90	constant	262	262	262	13.4	40	074 10012	48R6BFPP-5H <b>2281</b>	
94	256	3/4	230/460	18	8.9-127	10-90	constant	234	234	234	13.4	40	074 10012	48R6BFPP-5H N2282	
170	178	3/4	230/460	10	16-228	10-90	variable	152	210	180	13.4	40	074 10012	48R6BFPP-5H N2283	

<sup>1</sup> NOTE: Model numbers shown in bold type are in stock. "N" model numbers require lead time and minimum quantities.

<sup>2</sup> SOA: Contact the factory for detailed speed/torque information (Safe Operating Area). See page 37.

### 48R-5H Gearmotor

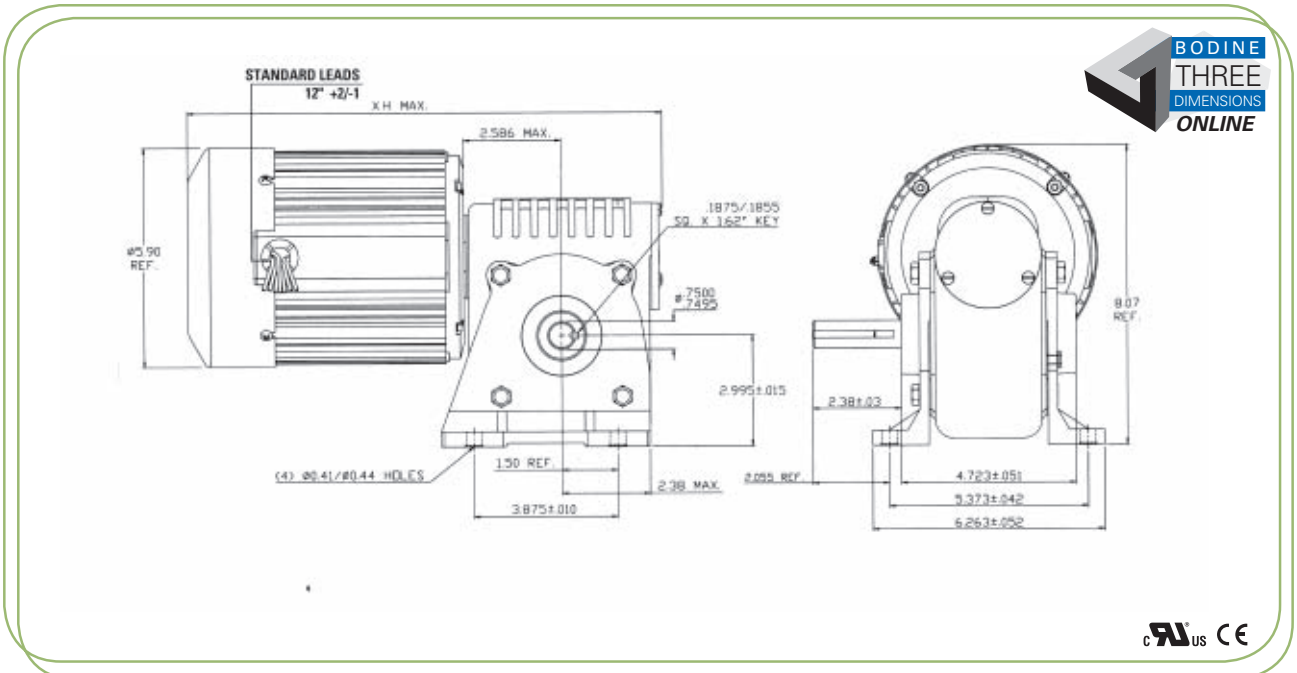

# Pacesetter Safe Operating Area (SOA) Data for Motors and Gearmotors

The Safe Operating Area (SOA) graphs below were generated using standard programmable settings found in most adjustable speed drives (inverters). The base frequency was set to 60 Hz, and the PWM switching frequency (carrier frequency) was set at 14 kHz.

### Safe Operating Torque and Speed Area (SOA)

Rated Torque is either the value of torque which corresponds to nameplate output power and speed at 60 Hz, or it is the maximum torque at gear strength limits (rated torque can be either motor limited or gear-limited).

SOA Torque is defined as the maximum torque at which the motor still operates within Class F thermal limits, or as the maximum torque of a gearmotor when it is gear-limited. Continuous duty

operation must be limited to the area below the SOA or gear-limited torque curves. The SOA torque for synchronous motors is close to the pull-in torque; that is, the motor will pull out of synchronism if the required torque exceeds the SOA torque.

The SOA speed of Bodine's Pacesetter™ non-synchronous motors is BELOW rated speed. For example, MOD#2295, 34R6BFPP has a rated torque of 148 oz-in. at a rated speed of 1700 rpm (60 Hz), but only a SOA speed of 1572 rpm (60 Hz) at 247 oz-in. SOA torque. The higher SOA torque will be produced at the trade-off of motor speed.

The starting currents listed in the **Figure 1** were measured with the motor connected to a three-phase power source. Starting currents may be

different when the motors or gearmotors are operated with an inverter drive.

The SOA Graphs for Bodine Electric inverter duty, three-phase, AC induction motors and gearmotors were generated by performance-testing all new designs over the full rated speed/frequency range. The SOA graphs will provide the data needed to successfully apply these new products. Optimized performance and highest output per frame size have always been the top priorities for the Bodine Electric design engineering team.

Please contact our Technical Support staff in Chicago if you have any further questions regarding the installation or operation of our Pacesetter™ inverter duty motors and gearmotors.

**Figure 1:** Starting Currents

Type	Speed (rpm)	Power HP	Phases	Voltage (V)	Frequency (Hz)	Starting Current Amps (trms)
34R4BFPP	1700	1/6	3	230	60	3.08
34R6BFPP	1700	1/4	3	230	60	4.13
34R6BFYP	1800	1/8	3	230	60	4.08
42R6BFPP	1700	3/8	3	230	60	6.72
48R6BFPP	1700	3/4	3	230/460	60	12.7/6.2
48R5BPYP	1800	1/3	3	230/460	60	12.07/5.85

Contact the factory for 30R starting current information.

**Figure 2:** Examples of typical "SOA" Graphs. Contact our technical support staff for specific SOA information.

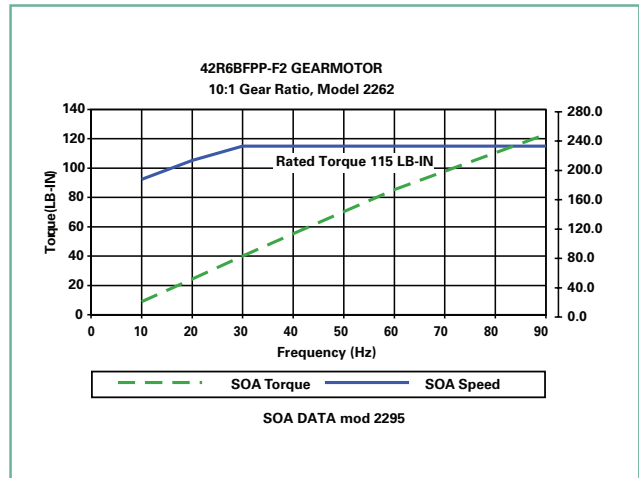
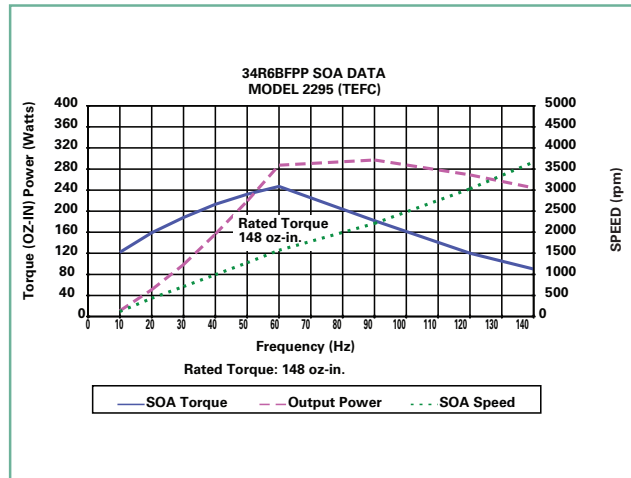

# AC Motor Controls

A variety of  
**products**  
to fit  
a variety of  
**applications**



## NEMA 4 Enclosures

See page 40

### Pacesetter NEMA 4

For superior environmental protection against spraying water and windblown dust



## Open Chassis Controls

See page 39

### Pacesetter OEM

For lowest cost and when an enclosure is already available



## NEMA 1 Enclosures

see page 41

### Pacesetter NEMA 1

With a convenient user interface and basic environmental protection





# Three-Phase AC Motor Speed Control

## OEM "Bare & Basic"

### Application Information

- Open chassis construction for installation into OEM machinery
- Speed control via external speed pot or external 0-5 VDC analog signal (isolation required)
- Trim pots for adjusting current limit, max. speed, min. speed, decel. time, accel. time, and slip compensation.

- Output frequency range selectable between 0-60 Hz and 0-120 Hz.
- Connector for remote direction control
- Connector for remote momentary start switch
- Protection against overload, overvoltage, undervoltage, and short circuit
- UL Listed, CE

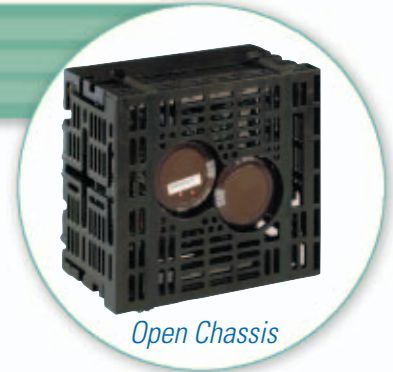

Open Chassis

1/2 HP Model Shown



Three-Phase AC Output Power				Single-Phase AC Input Power		Model Number
Motor HP	Motor Voltage	Motor Amps	Hz	Volts	Hz	
1/2	230	2.4	0 - 120	115	50 / 60	2982
1/2	230	2.4	0 - 120	230	50 / 60	2983
1/2	230	2.4	0 - 120	115 / 230	50 / 60	2984
1	230	4.0	0 - 120	115 / 230	50 / 60	2987

Models 2982, 2983, 2984

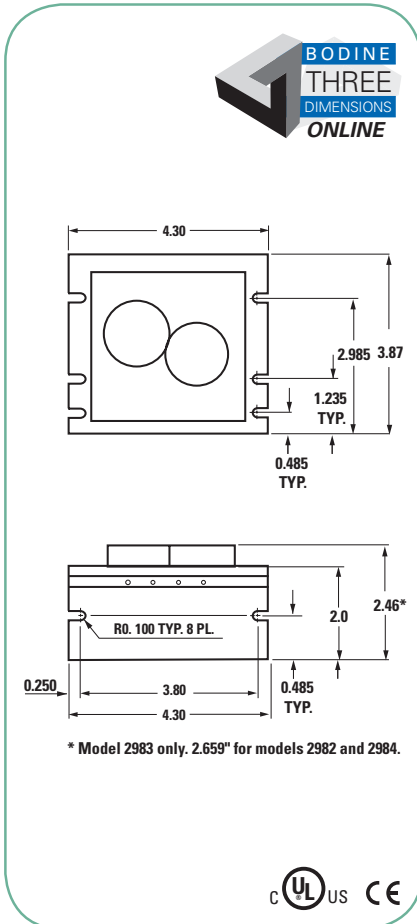

Models 2987

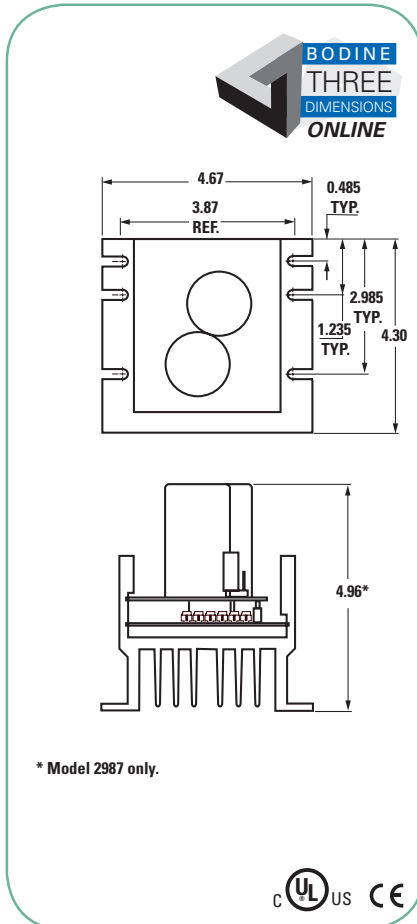

Connection Diagram

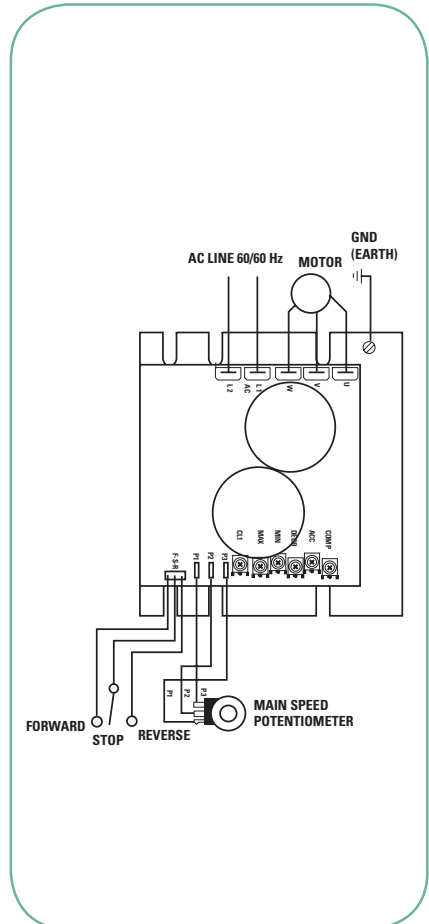

New  
e-TORQ™  
INTEGRAmotor™  
Hollow Shaft  
Custom  
PacEsetter™ Inverter Duty  
AC Induction  
Permanent Magnet DC  
Brushless DC  
Index

# Three-Phase AC Motor Speed Control

## NEMA 4 "Rough & Ready"



Waterproof Enclosure

### Application Information

- Type 4 enclosure for protection against windblown dust and spraying water
- Speed control via speed pot on front panel
- 11 functions adjustable via trim pots or dip switches inside enclosure
- 2 selectable Volts/Hz patterns for each input frequency (50/60 Hz)
- Forward-Stop-Reverse switch on front panel
- 1 dedicated logic output
- Dynamic braking
- Protection against overload, over voltage, under voltage, overheating, and motor short circuit
- Dimensions only 6.16" x 8.44" x 3.94"
- UL, cUL, CE



Three-Phase AC Output Power				Single-Phase AC Input Power		Model Number
Motor HP	Motor Voltage	Motor Amps	Hz	Volts	Hz	
1/2	230	2.4	0 – 120	115 / 230	50 / 60	2995



### Dimensions

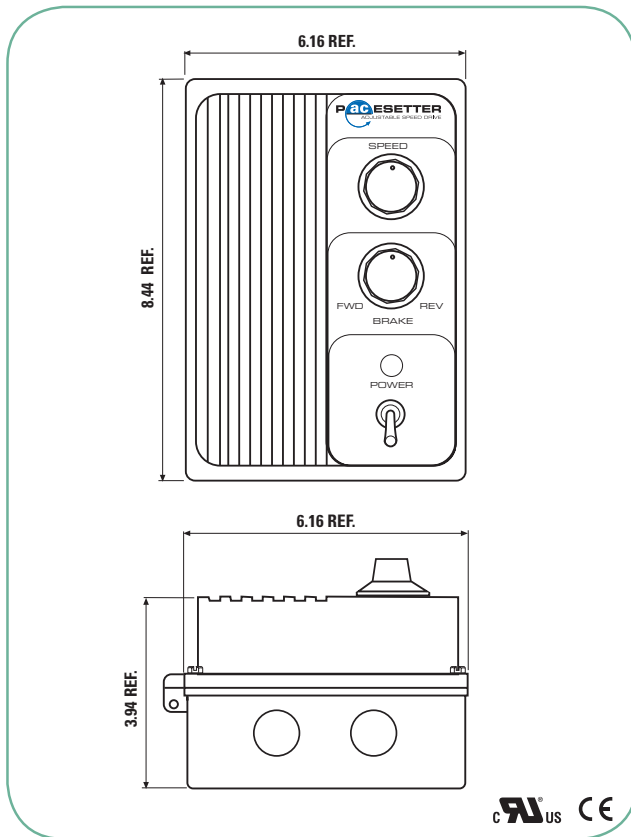

### Connection Diagram

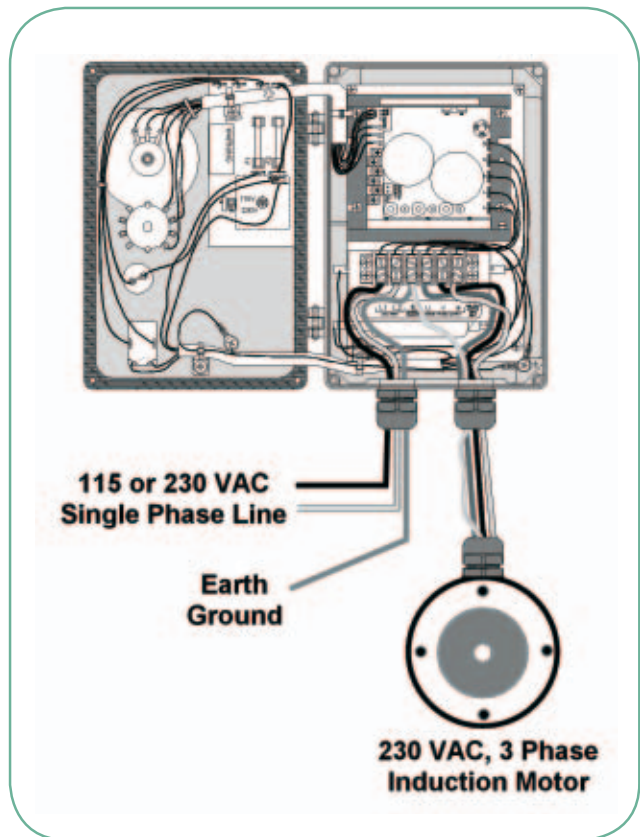

# Three-Phase AC Motor Speed Control

## NEMA 1

### Standard Features

- Operates from 115 Volt AC line with plug-in cord
- NEMA 1 enclosure to protect from bumps, drips, and falling objects
- Trim pots on PC board to adjust current limit, minimum speed limit, maximum speed limit, acceleration time, and deceleration time
- Speed can be adjusted manually using speed pot on front of enclosure
- Line fuse holder accessible from outside enclosure
- Toggle switch on front panel to turn AC power on/off
- Lamp on enclosure indicates when power is on
- Model 2996 has a direction switch

### Application Information

- Rated for continuous operation in 40° C ambient
- Drives Bodine 230 Volt 3-phase Induction Motors, or similar motors made by other manufacturers



IP-20 Enclosure



New

INTEGRAMOTOR™

Three-Phase AC Output Power				Single-Phase AC Input Power		Model Number
Motor HP	Motor Voltage	Motor Amps	Hz	Volts	Hz	
1/2	230	2.4	0 - 120	115	50 / 60	2996



Hollow Shaft

Custom

### Dimensions

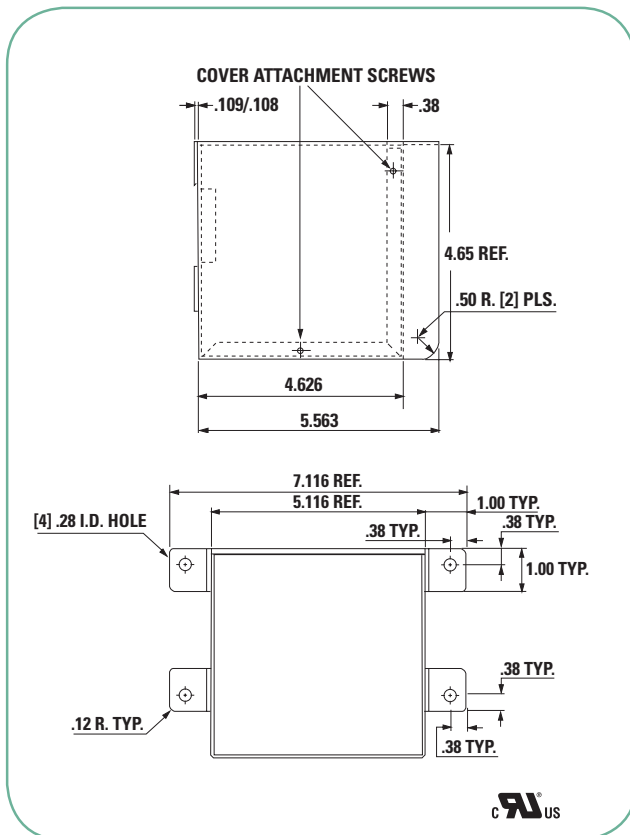

### Connection Diagram

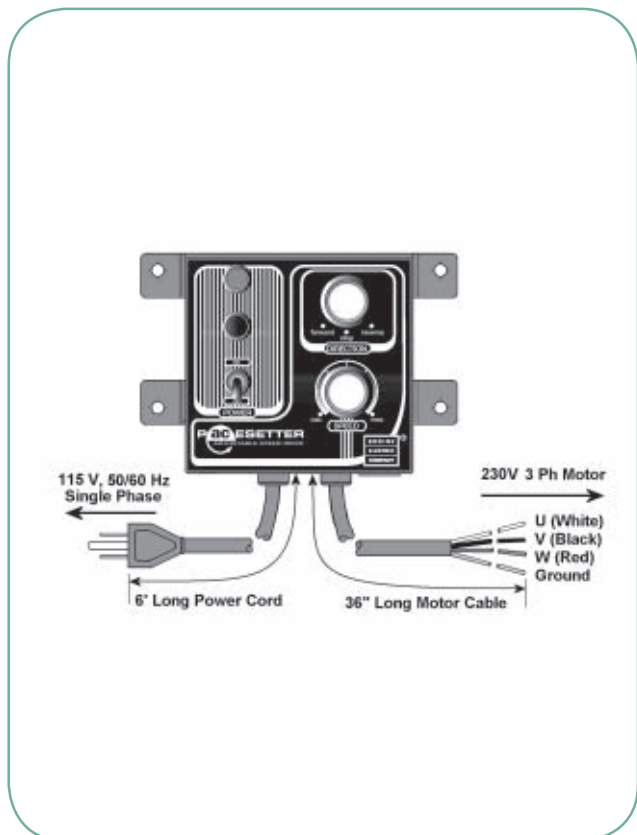

PacEsetter™ Inverter Duty

AC Induction

Permanent Magnet DC

Brushless DC

Index

# Three-Phase AC Motor Speed Controls

## Selection Table

Motor Model No. <sup>1</sup>	Bodine Motor Type	Rated HP	Rated Current (RMS)	Variable Speed (SOA) Ratings					Matching Control Models <sup>1,2</sup>				
				Speed (Rpm) Amps)	Freq. (Hz)	Torque @			OEM (New)			NEMA 1	NEMA 4
						10	60	Max	115	230	115/230	115	115/230
						Hz	Hz	Hz	V, CE	V, CE	V, CE	V	V, CE
Motor Torque In oz-in.													
<b>Non-synchronous Motors</b>													
<b>N2200</b>	30R2BEPP	1/25	0.38	220-3400	10-140	20	56	27	<b>2982</b>	<b>2983</b>	<b>2984</b>	<b>2996</b>	<b>2995</b>
<b>2201</b>	30R4BEPP	1/17	0.48	133-3240	10-140	45	66	35	<b>2982</b>	<b>2983</b>	<b>2984</b>	<b>2996</b>	<b>2995</b>
<b>2295</b>	34R6BFPP	1/4	1.2	120-3650	10-140	120	247	90	<b>2982</b>	<b>2983</b>	<b>2984</b>	<b>2996</b>	<b>2995</b>
N2234	34R6BFPP	1/4	1.2	120-3650	10-140	120	247	90	<b>2982</b>	<b>2983</b>	<b>2984</b>	<b>2996</b>	<b>2995</b>
<b>2235</b>	42R6BFPP	3/8	1.9	177-3500	10-140	170	281	137	<b>2982</b>	<b>2983</b>	<b>2984</b>	<b>2996</b>	<b>2995</b>
<b>2240</b>	48R6BFPP	3/4	2.7 (@ 230V)	160-3600	10-140	412	675	220	<b>2987</b>	<b>2987</b>	<b>2987</b>	–	–
<b>Synchronous Motors</b>													
<b>2299</b>	34R6BFYP	1/8	1.4	300-2400	10-80	54	103	48	<b>2982</b>	<b>2983</b>	<b>2984</b>	<b>2996</b>	<b>2995</b>
<b>2244</b>	48R5BFYP	1/3	2.4 (@ 230V)	300-2400	10-80	220	262	125	<b>2982</b>	<b>2983</b>	<b>2984</b>	<b>2996</b>	<b>2995</b>
<b>Gearmotor Torque In lb-in.</b>													
<b>Non-synchronous Parallel Shaft Gearmotors</b>													
<b>2210</b>	30R2BEPP-D4	1/25	0.38	1.6-14.7	10-90	40	40	40	<b>2982</b>	<b>2983</b>	<b>2984</b>	<b>2996</b>	<b>2995</b>
N2212	30R2BEPP-D4	1/25	0.38	2.6-28.7	10-90	40	40	40	<b>2982</b>	<b>2983</b>	<b>2984</b>	<b>2996</b>	<b>2995</b>
N2214	30R2BEPP-D3	1/25	0.38	3.1-41.6	10-90	40	40	40	<b>2982</b>	<b>2983</b>	<b>2984</b>	<b>2996</b>	<b>2995</b>
<b>2216</b>	30R4BEPP-D3	1/17	0.38	24-198	10-90	19	19	19	<b>2982</b>	<b>2983</b>	<b>2984</b>	<b>2996</b>	<b>2995</b>
<b>2220</b>	34R6BEPP-Z4	1/6	0.73	1.7-14.9	10-90	120	120	120	<b>2982</b>	<b>2983</b>	<b>2984</b>	<b>2996</b>	<b>2995</b>
N2222	34R6BEPP-Z4	1/6	0.73	2.6-28.7	10-90	120	120	120	<b>2982</b>	<b>2983</b>	<b>2984</b>	<b>2996</b>	<b>2995</b>
N2224	34R6BEPP-Z3	1/6	0.73	2.8-39	10-90	120	120	120	<b>2982</b>	<b>2983</b>	<b>2984</b>	<b>2996</b>	<b>2995</b>
<b>2226</b>	34R6BEPP-Z3	1/6	0.73	9.9-89.3	10-90	96	96	96	<b>2982</b>	<b>2983</b>	<b>2984</b>	<b>2996</b>	<b>2995</b>
N2227	34R6BEPP-Z2	1/6	0.73	16-143	10-90	39	39	39	<b>2982</b>	<b>2983</b>	<b>2984</b>	<b>2996</b>	<b>2995</b>
N2228	34R6BEPP-Z2	1/6	0.73	33-433	10-90	21	21	21	<b>2982</b>	<b>2983</b>	<b>2984</b>	<b>2996</b>	<b>2995</b>
<b>2250</b>	34R4BFPP-E4	1/6	1.0	1.4-14.5	10-90	341	341	341	<b>2982</b>	<b>2983</b>	<b>2984</b>	<b>2996</b>	<b>2995</b>
<b>2251</b>	34R4BFPP-E4	1/6	1.0	2.6-28.7	10-90	250	250	250	<b>2982</b>	<b>2983</b>	<b>2984</b>	<b>2996</b>	<b>2995</b>
<b>2252</b>	34R4BFPP-E3	1/6	1.0	3.1-41.6	10-90	250	270	270	<b>2982</b>	<b>2983</b>	<b>2984</b>	<b>2996</b>	<b>2995</b>
N2253	34R4BFPP-E3	1/6	1.0	7.4- 84	10-90	–	–	–	<b>2982</b>	<b>2983</b>	<b>2984</b>	<b>2996</b>	<b>2995</b>
N2254	34R4BFPP-E2	1/6	1.0	30-260	10-90	–	–	–	<b>2982</b>	<b>2983</b>	<b>2984</b>	<b>2996</b>	<b>2995</b>
N2255	34R4BFPP-E1	1/6	1.0	35-493	10-90	–	–	–	<b>2982</b>	<b>2983</b>	<b>2984</b>	<b>2996</b>	<b>2995</b>
<b>2260</b>	42R6BFPP-F3	3/8	1.9	7.4-84	10-90	250	250	250	<b>2982</b>	<b>2983</b>	<b>2984</b>	<b>2996</b>	<b>2995</b>
<b>2261</b>	42R6BFPP-F3	3/8	1.9	11-127	10-90	167	167	167	<b>2982</b>	<b>2983</b>	<b>2984</b>	<b>2996</b>	<b>2995</b>
<b>2262</b>	42R6BFPP-F2	3/8	1.9	17-246	10-90	92	115	115	<b>2982</b>	<b>2983</b>	<b>2984</b>	<b>2996</b>	<b>2995</b>
<b>2263</b>	42R6BFPP-F1	3/8	1.9	35-493	10-90	48	58	58	<b>2982</b>	<b>2983</b>	<b>2984</b>	<b>2996</b>	<b>2995</b>
<b>Non-synchronous Right Angle Gearmotors</b>													
N2236	42R6BFPP-GB	3/8	1.9	0.7-9.3	–	–	–	–	<b>2982</b>	<b>2983</b>	<b>2984</b>	<b>2996</b>	<b>2995</b>
<b>2237</b>	42R6BFPP-GB	3/8	1.9	2.2-22	10-90	290	290	290	<b>2982</b>	<b>2983</b>	<b>2984</b>	<b>2996</b>	<b>2995</b>
N2238	42R6BFPP-GB	3/8	1.9	3.1-41.6	–	–	–	–	<b>2982</b>	<b>2983</b>	<b>2984</b>	<b>2996</b>	<b>2995</b>
<b>2270</b>	42R6BFPP-5N	3/8	1.9	3.4-35.1	10-90	121	121	116	<b>2982</b>	<b>2983</b>	<b>2984</b>	<b>2996</b>	<b>2995</b>
<b>2271</b>	42R6BFPP-5N	3/8	1.9	6.3-65	10-90	109	109	109	<b>2982</b>	<b>2983</b>	<b>2984</b>	<b>2996</b>	<b>2995</b>
<b>2272</b>	42R6BFPP-5N	3/8	1.9	11.8-130	10-90	98	98	98	<b>2982</b>	<b>2983</b>	<b>2984</b>	<b>2996</b>	<b>2995</b>
<b>2273</b>	42R6BFPP-5N	3/8	1.9	17.7-248	10-90	66	105	101	<b>2982</b>	<b>2983</b>	<b>2984</b>	<b>2996</b>	<b>2995</b>
<b>2274</b>	42R6BFPP-5N	3/8	1.9	35.4-458	10-90	38	68	59	<b>2982</b>	<b>2983</b>	<b>2984</b>	<b>2996</b>	<b>2995</b>
N2275	42R6BFPP-5N	3/8	1.9	5.9-77	10-90	104	104	104	<b>2982</b>	<b>2983</b>	<b>2984</b>	<b>2996</b>	<b>2995</b>
N2280	48R6BFPP-5H	3/4	2.7 (@ 230V)	4-54	–	–	–	–	<b>2987</b>	<b>2987</b>	<b>2987</b>	–	–
<b>2281</b>	48R6BFPP-5H	3/4	2.7 (@ 230V)	5.9-69	10-90	285	285	262	<b>2987</b>	<b>2987</b>	<b>2987</b>	–	–
N2282	48R6BFPP-5H	3/4	2.7 (@ 230V)	11-144	–	–	–	–	<b>2987</b>	<b>2987</b>	<b>2987</b>	–	–
N2283	48R6BFPP-5H	3/4	2.7 (@ 230V)	17-246	–	–	–	–	<b>2987</b>	<b>2987</b>	<b>2987</b>	–	–
N2290	30R4BEPP-3N	1/17	0.48	3-40	10-90	–	–	–	<b>2982</b>	<b>2983</b>	<b>2984</b>	<b>2996</b>	<b>2995</b>
N2292	30R4BEPP-3N	1/17	0.48	6-51	10-90	–	–	–	<b>2982</b>	<b>2983</b>	<b>2984</b>	<b>2996</b>	<b>2995</b>
N2293	30R4BEPP-3N	1/17	0.48	7-64	10-90	–	–	–	<b>2982</b>	<b>2983</b>	<b>2984</b>	<b>2996</b>	<b>2995</b>
N2294	30R4BEPP-3N	1/17	0.48	11-125	10-90	–	–	–	<b>2982</b>	<b>2983</b>	<b>2984</b>	<b>2996</b>	<b>2995</b>
N2296	30R4BEPP-3N	1/17	0.48	20-250	10-90	–	–	–	<b>2982</b>	<b>2983</b>	<b>2984</b>	<b>2996</b>	<b>2995</b>
N2297	30R4BEPP-3N	1/17	0.48	35-460	10-90	–	–	–	<b>2982</b>	<b>2983</b>	<b>2984</b>	<b>2996</b>	<b>2995</b>

<sup>1</sup> Model numbers shown in bold type are in stock. "N" model numbers require lead time and minimum quantities.

<sup>2</sup> Matching control model ratings are for single-phase AC input voltages, 230V Three-phase AC output.

NOTE: Some of the newer motors and gearmotors shown in this catalog do not yet appear in these tables. Refer to [www.bodine-electric.com](http://www.bodine-electric.com) for the most up-to-date information.

# AC Technical Information

## Permanent Split Capacitor Motors

Permanent Split Capacitor motors, Bodine types "CI" and "YC", are designed for single speed applications using single-phase power. They are recommended for continuous duty applications or start-stop applications with up to 10 starts per minute. Bodine types "CI" and "YC" motors feature high efficiency and reliable service. These motors require continuous duty, motor-run capacitors connected in the auxiliary winding circuit to produce starting torque.

Non-synchronous designs provide the highest output power of permanent split capacitor motors. Speed change will be less than 6% from No-Load to Full Load. Available starting torque is approximately the same as rated torque.

Synchronous designs provide exact speed from No-Load to Full Load. Power output is lower than non-synchronous motors of the same size. Available starting torque is approximately the same as rated torque.

## Split Phase Motors

Split Phase motors, Bodine types "SI" and "SY", are designed for single speed applications using single-phase power. They are recommended for continuous duty applications or start-stop applications with up to 6 starts per hour. The specially designed auxiliary

winding produces starting torque and is then disconnected by an internal, mechanical, centrifugal starting switch. Because of this switch 60 Hz motors cannot be operated at 50 Hz. No start or run capacitor is required. However, an electrolytic start capacitor may be connected in series with the auxiliary winding to increase starting torque and reduce starting current. Suggested values for these capacitors are shown in the table at the top of page 63.

Non-synchronous designs provide the highest output power of split phase motors. Speed change will be less than 6% from No-Load to Full Load. Available starting torque is typically 1.5 to 3 times rated torque.

Synchronous designs provide exact speed from No-Load to Full Load. Power output is lower than non-synchronous motors of the same size. Available starting torque is typically somewhat higher than rated torque.

## Three-Phase Motors

Standard three-phase motors, Bodine types "PP" (non-synchronous), and "YP" (synchronous), are designed for single speed applications using three-phase power. For variable speed applications, refer to our line of PACESETTER™ inverter duty motors, gearmotors, and AC drives.

Bodine fixed speed three-phase motors and gearmotors are recommended for continuous duty applications of start-stop applications with up to 10 starts per minute. Bodine types "PP" and "YP" motors feature high efficiency and reliable performance in a compact package. Non-synchronous designs provide the highest output power of all AC induction motor. Speed change will be less than 6% from No-Load to Full Load. Available starting torque is typically 1.5 to 3 times the rated torque.

Synchronous designs provide exact speed from No-Load to Full Load. Horsepower rating is lower than non-synchronous motors of the same size. Available starting torque is typically somewhat higher than rated torque.

**Please contact the factory or your local Bodine representative with PACESETTER™ inverter duty application requirements and for technical support.**

## CE Certificaton

Most Bodine motors and gearmotors meet CE standards. See page 2 for more information.

## R Frame AC motor Information IP-44 Construction

With a properly installed die cast terminal box (model no. 0984 or model no. 5982), Bodine "R" Frame motors and gearmotors meet IP-44 construction as specified in IEC standard 34-5. The IP-44 designation means that a motor is designed to protect against solid bodies greater than 1 mm and water splashed from any direction.

## Electrolytic Capacitors with 42R and 48R Split Phase 115/230 Volt Motors

Starting current for split phase motors is significantly higher than running current. The insertion of an electrolytic capacitor in the starting winding circuit (white leads) of nine wire split phase motors can reduce starting current by approximately 50%. Suggested electrolytic capacitor values are listed below. Bodine does not supply these capacitors.

Motor/Gearmotor Model No.	Voltage Connection	
	115 Volt	230 Volt
0284	180 mfd.	64 mfd.
0285	145 mfd.	43 mfd.
0661, 0662, 0663, 0664	180 mfd.	64 mfd.
0251	140 mfd.	—
0253, 0254	300 mfd.	—
0255	220 mfd.	—

## 48R Frame Motors and NEMA Standards

Stocked 48R motors are 48 frame diameter motors with NEMA 56 frame face mounting shield and shaft. With the motor base removed, the mounting face and shaft configuration meet NEMA 56 standard dimensions, enabling these stocked motors to be used in conjunction with many separable gearheads available.

Because Bodine 48R frame motors are shorter than typical competitive 48 frame motors of equivalent horsepower rating, the dimension from the face to the first base mounting hole (designated "BA" by NEMA) is shorter than 48 NEMA standard for these motors.

# AC Induction Torque Motors

## Technical Information

Bodine AC torque motors are designed to run at stall or produce reverse torque intermittently at rated voltage. They may be used at stall or to produce reverse torque continuously at the reduced voltage shown in the specification table. AC torque motors are specially designed permanent split capacitor motors. They are often used in winding applications on the take-up reel. When the reel is empty, it rotates at its highest speed, but does not require much torque. When the reel is full, it rotates at a low speed and requires more torque. Torque motors can also be used in tensioning or holding applications. They can safely produce reverse torque while being backdriven at any normal operating speed. Reverse torque will be approximately equal to stall torque. They have high slip rotors that produce near linear speed torque characteristics (see figure 1). Maximum torque is produced at stall with less torque available as the motor speeds up in the forward direction.

## Standard Features

- Will operate satisfactorily on 50 or 60 Hz
- Special rotor provides excellent performance for holding, winding and tensioning applications
- Special windings can provide locked rotor or reverse torque intermittently at rated voltage or continuously at reduced voltage
- Totally enclosed non-ventilated IP-20 rating
- Permanently lubricated, noise tested ball bearings
- Locked bearing design on 30R, 42R, and 48R minimizes shaft endplay

## Application Information

- See page 64 for connection diagram 074 10021
- K-2 motors include capacitors
- 30R, 42R, and 48R motors do not include capacitors, See page 63
- Face mounting is standard
- 42R and 48R motors also include base mount.

## Optional Accessories

- 30R die cast terminal box kit model 5982 achieves IP-44 rating, see page 62
- For 42R, 48R die cast terminal box kit model 0984 achieves IP-44 rating, see page 62



rpm @ No Load	Locked Rotor				V	Hz	Weight (lbs.)	Capacitor Part No.	Product Type	Model Number
	Torque (oz-in.)	Watts	Max. On Time (min.)	% Duty Cycle						
1580	7.0	22	5	40	115	60	2.25	494 01047*	KCI-26	0621
1570	3.5	12	—	100	83	60	2.25	494 01047*	KCI-26	0621
1310	6.0	19	5	40	115	50	2.25	494 01047*	KCI-26	0621
1300	4.0	13	—	100	92	50	2.25	494 01047*	KCI-26	0621
1660	25	52	30	50	115	60	4.75	494 01015	30R2FECI	5625
1645	19	40	—	100	100	60	4.75	494 01015	30R2FECI	5625
1425	25	47	30	50	115	50	4.75	494 01015	30R2FECI	5625
1420	19	36	—	100	100	50	4.75	494 01015	30R2FECI	5625
1690	38	85	28	40	115	60	12.5	494 00031	42R6FECI	2628
1680	22	49	—	100	87	60	12.5	494 00031	42R6FECI	2628
1445	38	82	28	40	115	50	12.5	494 00031	42R6FECI	2628
1435	22	47	—	100	87	50	12.5	494 00031	42R6FECI	2628
1560	65	120	15	40	115	60	20	494 00033	48R6FECI	0632
1560	32	60	—	100	80	60	20	494 00033	48R6FECI	0632
1370	68	96	15	40	115	50	20	494 00033	48R6FECI	0632
1360	34	58	—	100	80	50	20	494 00033	48R6FECI	0632

\*Capacitor part number 494 01047 is supplied with model number 0621.

Figure 1 Typical performance curves at 115 V, 60 Hz

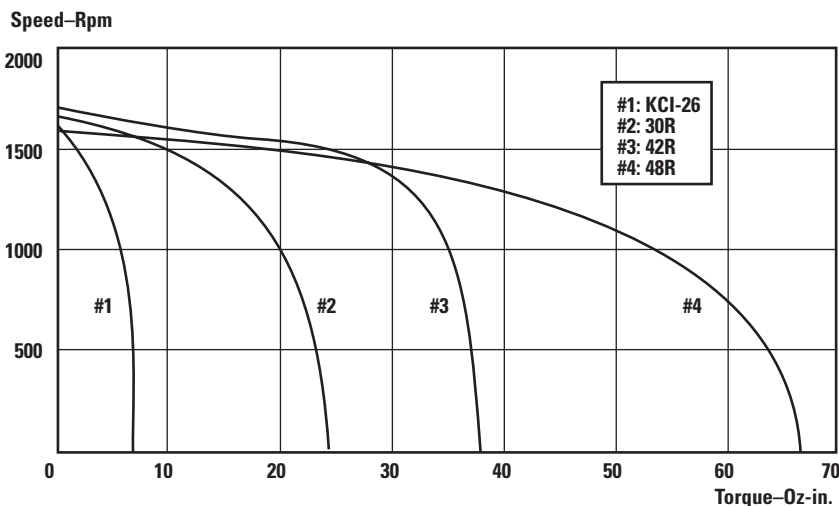

# AC Induction Torque Motors

## K-2 Torque Motor (model 0621)

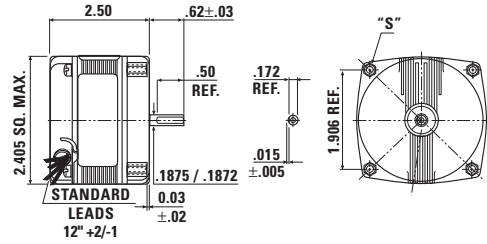

"S" (4) .164-32, .14 in. min. deep on 2.68±.01 in. bolt circle



## 30R Torque Motor (model 5625)

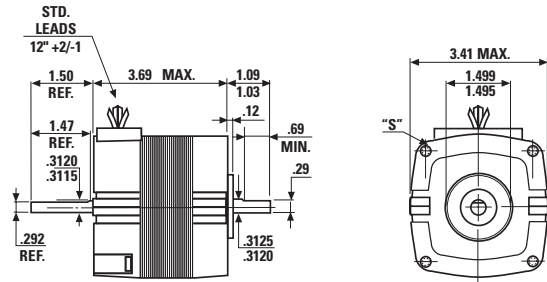

"S" (4) #10-32, .32+.06/-00 in. deep on 3.75 in. bolt circle



## 42R Torque Motor (model 2628)

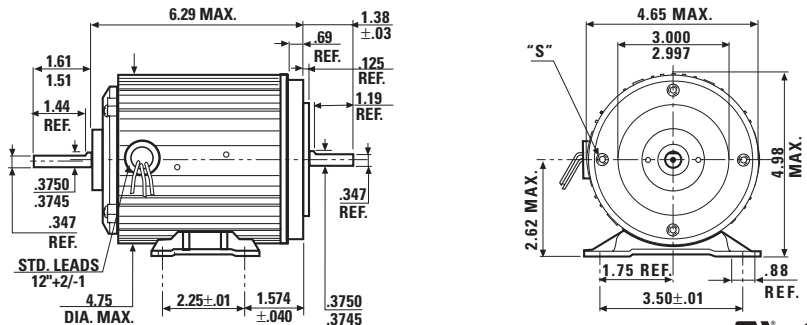

"S" (4) 1/4-20, UNC-2B, .31 in. min. deep on 3.75 in. bolt circle



## 48R Torque Motor (model 0632 shown with optional terminal box, model 0984)

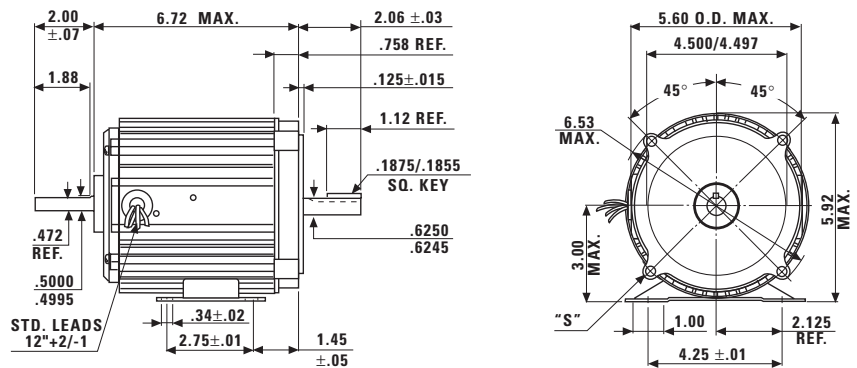

"S" (4) 3/8-16, UNC-2B, .50 in. min. deep on 5.875 in. bolt circle



# AC Induction Motors

1/1600 - 1/200 HP



K-2

### Standard features

- Totally enclosed, non-ventilated IP-20 rating
- Permanently lubricated, noise tested ball bearings
- Three-wire winding simplifies reversing circuitry
- Impedance protected to prevent current overload (motor can be stalled indefinitely without overheating)

### Application Information

- See page 64 for connection diagrams
- Capacitor is included with motor
- Face mounting is standard

### Typical Performance Curves

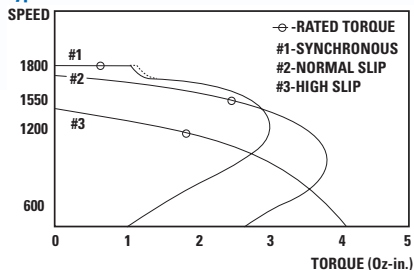

Speed (rpm)	Rated Torque (oz-in.)	HP	V	Hz	Ph	A	Radial Load (lbs.)	Length XH (inch)	Weight (lbs.)	Connection Diagram	Capacitor Part No.	Product Type	Model No. <sup>1</sup>
<b>Permanent Split Capacitor normal slip, Non-synchronous</b>													
1550	1.4	1/450	115	60	1	.080	5.7	1.84	1.6	074 10019	494 00046	KCI-23	<b>0705</b>
1550	2.2	1/300	115	60	1	.104	5.7	2.20	1.9	074 10019	494 00048	KCI-24	<b>0712</b>
1550	3.2	1/200	115	60	1	.124	5.7	2.50	2.2	074 10019	494 00051	KCI-26	<b>0713</b>
1250	3.0	-	230	50	1	.060	5.7	2.50	2.2	074 10021	494 01049	KCI-26	N1713
<b>Permanent Split Capacitor High Slip, Non-synchronous</b>													
1200	1.1	1/800	115	60	1	.082	5.7	1.84	1.6	074 10019	494 00046	KCI-23	<b>0707</b>
1200	1.8	1/450	115	60	1	.098	5.7	2.20	1.9	074 10019	494 00047	KCI-24	<b>0714</b>
<b>Permanent Split Capacitor, Synchronous</b>													
1800	.35	1/1600	115	60	1	.077	5.7	1.84	1.6	074 10019	494 00046	KYC-23	<b>0701</b>
1800	.62	1/900	115	60	1	.091	5.7	2.20	1.9	074 10019	494 00048	KYC-24	<b>0709</b>
3600	.31	1/900	115	60	1	.102	5.7	2.20	1.9	074 10019	494 00051	KYC-24	<b>0710</b>

<sup>1</sup> NOTE: Model numbers shown in bold type are in stock. "N" model numbers require lead time and minimum quantities.

### K-2 AC Motor

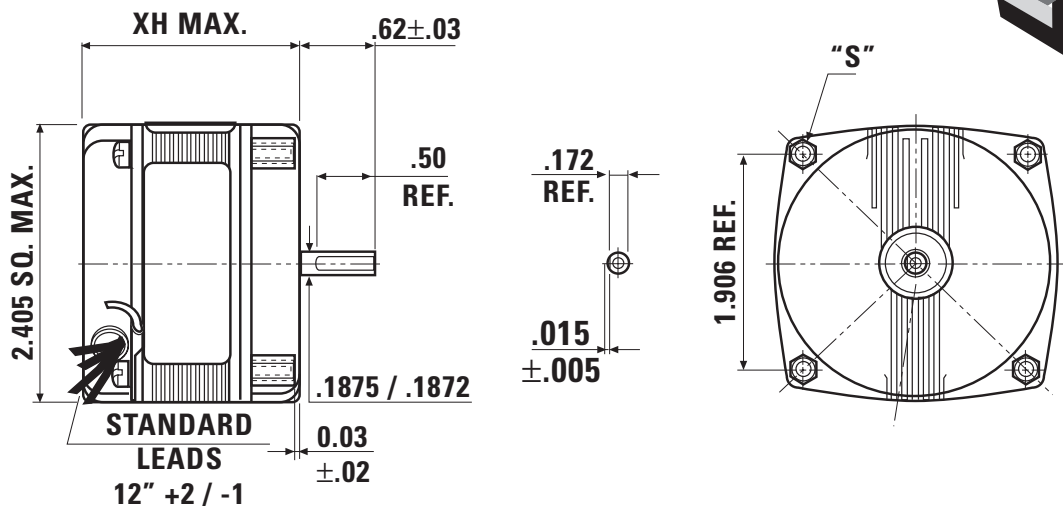

"S" (4) .164-32, .14" deep minimum on a 2.68 in. bolt circle





# AC Induction Motors

1/40 - 1/30 HP

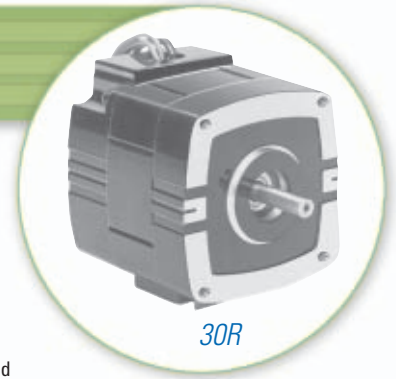

30R

### Standard features

- Totally enclosed, non-ventilated IP-20 rating
- Class B insulation system for long life
- Aluminum endshields for high thermal efficiency and light weight
- Permanently lubricated, noise tested ball bearings
- Locked bearing design minimizes shaft endplay

### Application Information

- See page 64 for connection diagrams
- Capacitor is not included. Order with motor, see page 63
- Face mounting is standard

### Optional Accessories

- Die cast terminal box kit model 5982 achieves IP-44 rating, see page 62
- "L" bracket kit model 5968 permits base, ceiling, and sidewall mounting, see page 62

FOR INVERTER DUTY MODELS



SEE PAGES 24-42

Speed (rpm)	Rated Torque (oz-in.)	HP	V	Hz	Ph	A	Radial Load (lbs.)	Length XH (inch)	Weight (lbs.)	Connection Diagram	Capacitor Part No.	Product Type	Model Number
<b>Permanent Split Capacitor, Non-synchronous</b>													
1700	20	1/30	115	60	1	.45	18	3.69	4.75	074 10296	494 01015	30R2BECI	5240
3400	10	1/30	115	60	1	.47	18	3.69	4.75	074 10296	494 01015	30R2BECI	5219
<b>Permanent Split Capacitor, Synchronous</b>													
1800	14	1/40	115	60	1	.52	18	3.69	4.75	074 10296	494 01015	30R2BEYC	5246

30R Motor shown with optional "L" bracket (model 5968)

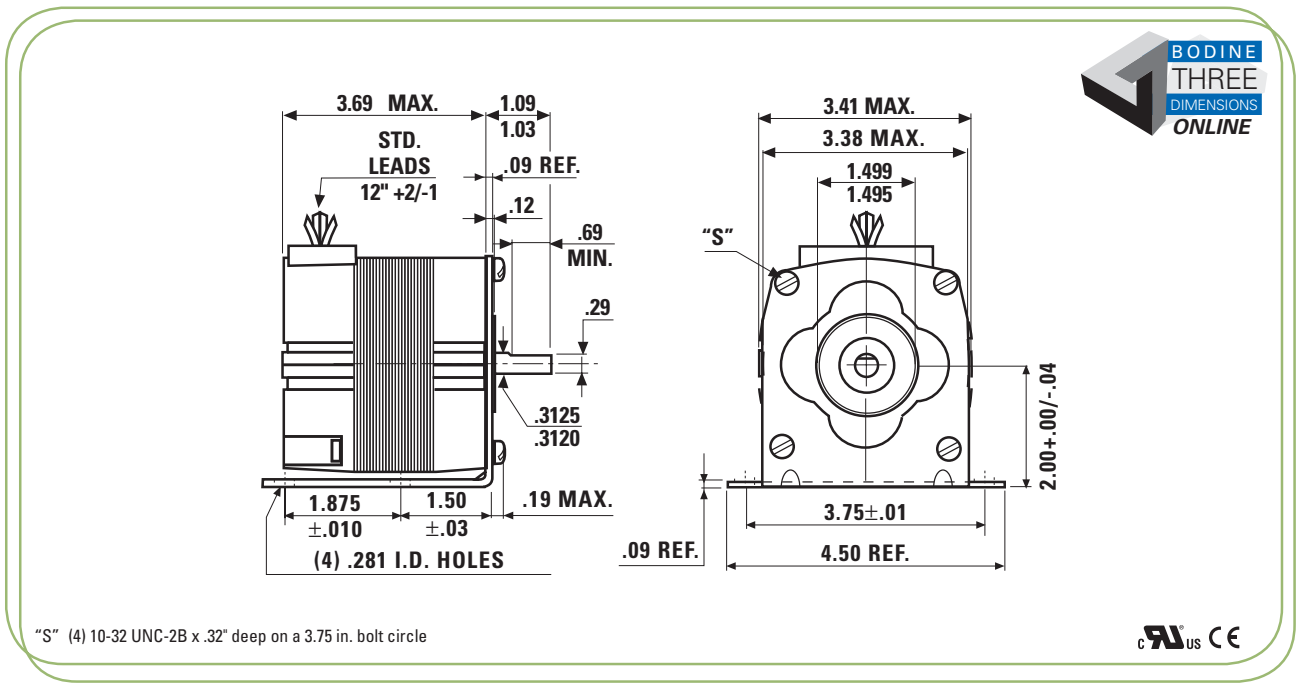

MADE IN U.S.A.

New e-TORQ™ INTEGRAmotor™ Hollow Shaft Custom Pacemaker™ Inverter Duty AC Induction Permanent Magnet DC Brushless DC Index

# AC Induction Motors

1/15 - 1/5 HP



34R

### Standard Features

- Totally enclosed IP-20 rating
- Fan cooled for high output power
- Class B insulation system operated within Class A limits to prolong winding and lubricant life
- Aluminum center ring and endshields for high thermal efficiency and light weight
- Permanently lubricated, noise tested ball bearings
- Locked bearing design minimizes shaft endplay

### Application Information

- See page 64 for connection diagrams
- Capacitor is not included. Order with motor, see page 63
- Face mounting is standard
- Motors operate satisfactorily on 50 Hz

### Optional Accessories

- Die cast terminal box kit model 0984,1984 achieves IP-44 rating, see page 62
- "L" bracket kit model 0979 permits base, ceiling, and sidewall mounting, see page 62
- Base plate model 0994 available, see page 62

FOR INVERTER DUTY MODELS



SEE PAGES 24-42

Speed (rpm)	Rated Torque (oz-in.)	HP	V	Hz	Ph	A	Radial Load (lbs.)	Length XH (inch)	Weight (lbs.)	Connection Diagram	Capacitor Part No.	Product Type	Model Number <sup>1</sup>
<b>Permanent Split Capacitor, Non-synchronous</b>													
1700	39	1/15	115	60	1	1.0	50	5.69	7	074 10296	494 01054	34R4BFCI	<b>0290</b>
1700	65	1/9	115	60	1	1.4	50	6.69	9	074 10296	494 01006	34R6BFCI	<b>0291</b>
3400	42	1/7	115	60	1	1.75	50	6.69	9	074 10296	494 01016	34R6BFCI	<b>0293</b>
<b>Permanent Split Capacitor, Synchronous</b>													
1800	38	1/15	115	60	1	1.5	50	6.69	9	074 10296	494 01016	34R6BFYC	N0297
<b>Three-phase, Non-synchronous</b>													
1700	119	1/5	230	60	3	1.2	50	6.69	9	074 10102	—	34R6BFPP	<b>0295</b>
<b>Three-phase, Synchronous</b>													
1800	70	1/8	230	60	3	1.4	50	6.69	9	074 10102	—	34R6BFYP	<b>0299</b>

<sup>1</sup> NOTE: Model numbers shown in bold type are in stock. "N" model numbers require lead time and minimum quantities.

34R Motor with NEMA C face mount and optional "L" bracket (model 0979)

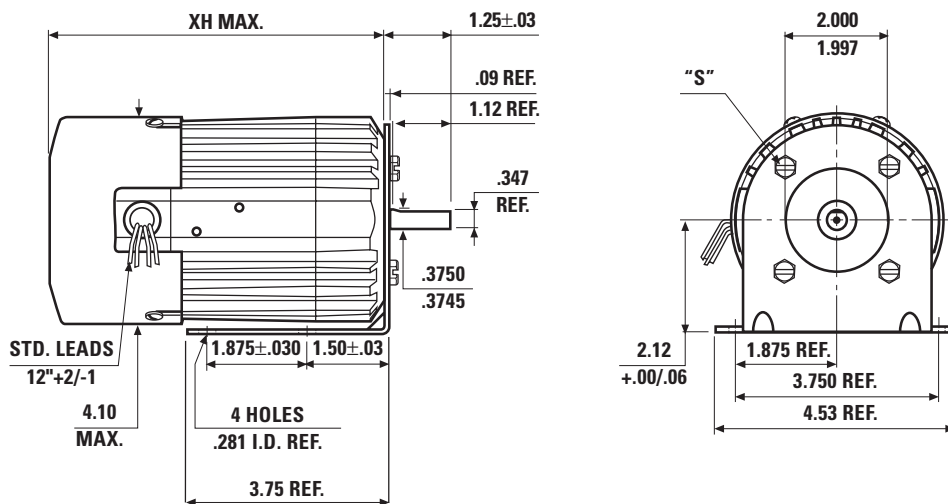

"S" (4) 1/4-20, UNF-2B, .31/.38 in. deep minimum on a 2.75 in. bolt circle



# AC Induction Motors

1/12 - 1/4 HP



42R

### Standard Features

- Totally enclosed IP-20 rating
- Fan cooled for high output power
- Class B insulation system operated within Class A limits to prolong winding and lubricant life
- Aluminum center ring and endshields for high thermal efficiency and light weight
- Permanently lubricated, noise tested ball bearings
- Locked bearing design minimizes shaft endplay

### Application Information

- See page 64 for connection diagrams
- Capacitor is not included. Order with motor, see page 63
- Face or base mounting is standard
- For lower cost, high volume applications, see 44C motors on page 18

### Optional Accessories

- Die cast terminal box kit model 0984,1984 achieves IP-44 rating, see page 62
- Steel terminal box kit model 0982 shown on page 62

FOR INVERTER DUTY MODELS



SEE PAGES 24-42

Speed (rpm)	Rated Torque (oz-in.)	HP	V	Hz	Ph	A	Radial Load (lbs.)	Length XH (inch)	Weight (lbs.)	Connection Diagram	Capacitor Part No.	Product Type	Model Number	
													NEMA C	Base Mount
<b>Permanent Split Capacitor, Non-synchronous</b>														
1700	101	1/6	115	60	1	1.9	50	6.70	11	074 10296	494 00034	42R5BFCI	<b>0260</b>	<b>0258</b>
<b>Split phase (with centrifugal switch), Non-synchronous</b>														
1700	48	1/12	115	60	1	2.4	50	5.64	7.75	074 10292	—	42R3BFSI	N0261	<b>0251</b>
1700	101	1/6	115	60	1	3.6	50	6.70	11	074 10292	—	42R5BFSI	<b>0254</b>	<b>0253</b>
3450	50	1/6	115	60	1	3.3	50	6.70	11	074 10292	—	42R5BFSI	N0265	<b>0255</b>
<b>Three-phase, Non-synchronous</b>														
1700	148	1/4	230	60	3	1.2	50	6.70	11	074 10102	—	42R5BFPP	N0263	<b>0273</b>
1700	148	1/4	230/460	60	3	1.2/0.6	50	6.70	11	074 10103	—	42R5BFPP	N0264	<b>0274</b>

<sup>1</sup> NOTE: Model numbers shown in bold type are in stock. "N" model numbers require lead time and minimum quantities.

**42R Motor** Top: with NEMA C face mount and optional die cast terminal box (model 0984). Bottom: with base mount

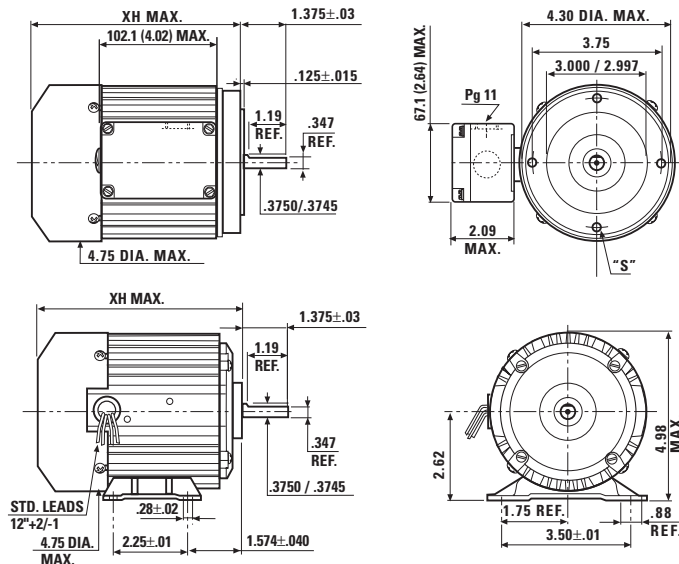

"S" (4) 1/4-20, UNF-2B, .31 in. deep minimum on a 3.75 in. bolt circle



# AC Induction Motors

1/5 - 1/2 HP

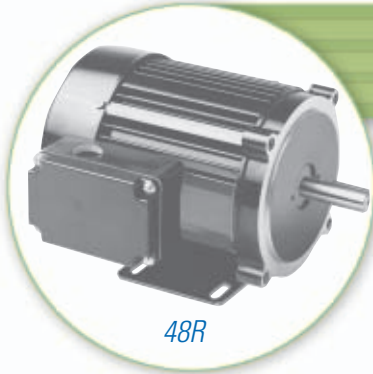

48R

### Standard Features

- Totally enclosed IP-20 rating
- Fan cooled for high output power
- Class B insulation system operated within Class A limits to prolong winding and lubricant life
- Aluminum center ring and endshields for high thermal efficiency and light weight
- Permanently lubricated, noise tested ball bearings
- Locked bearing design minimizes shaft endplay

### Application Information

- See page 64 for connection diagrams
- Capacitor is not included. Order with motor, see page 63
- Base mounting and NEMA 56C face are standard

### Optional Accessories

- Die cast terminal box kit model 0984, 1984 achieves IP-44 rating, see page 62
- Steel terminal box kit model 0982 shown on page 62

FOR INVERTER DUTY MODELS



SEE PAGES 24-42

Speed (rpm)	Rated Torque (oz-in.)	HP	V	Hz	Ph	A	Radial Load (lbs.)	Length XH (inch)	Weight (lbs.)	Connection Diagram	Capacitor Part No.	Product Type	Model Number
<b>Permanent Split Capacitor, Non-synchronous</b>													
1700	196	1/3	115	60	1	4.0	205	7.78	20.5	074 10294	494 00035	48R6BFCI	0283
1700	196	1/3	230	60	1	2.0	205	7.78	20.5	074 10294	494 00033	48R6BFCI	0283
<b>Split phase non-Synchronous (with centrifugal switch)</b>													
1700	196	1/3	115/230	60	1	4.8/2.4	205	7.78	20.5	074 10298	—	48R6BFSI	0284
<b>Split phase Synchronous (with centrifugal switch)</b>													
1800	112	1/5	115/230	60	1	6.0/3.0	205	7.78	20.5	074 10298	—	48R6BFSY	0285
<b>Three-phase, Non-synchronous</b>													
1400	296	1/3	230	50	3	2.2	205	7.78	20.5	074 10103	—	48R6BFPP	0286
1700	296	1/2	230	60	3	1.8	205	7.78	20.5	074 10103	—	48R6BFPP	0286
1400	296	1/3	460	50	3	1.1	205	7.78	20.5	074 10103	—	48R6BFPP	0286
1700	296	1/2	460	60	3	0.9	205	7.78	20.5	074 10103	—	48R6BFPP	0286
<b>Three-phase, Synchronous</b>													
1800	185	1/3	230/460	60	3	2.1/1.1	205	7.31	17	074 10103	—	48R5BFYP	0281

48R Motor shown with optional terminal box (model 0984)

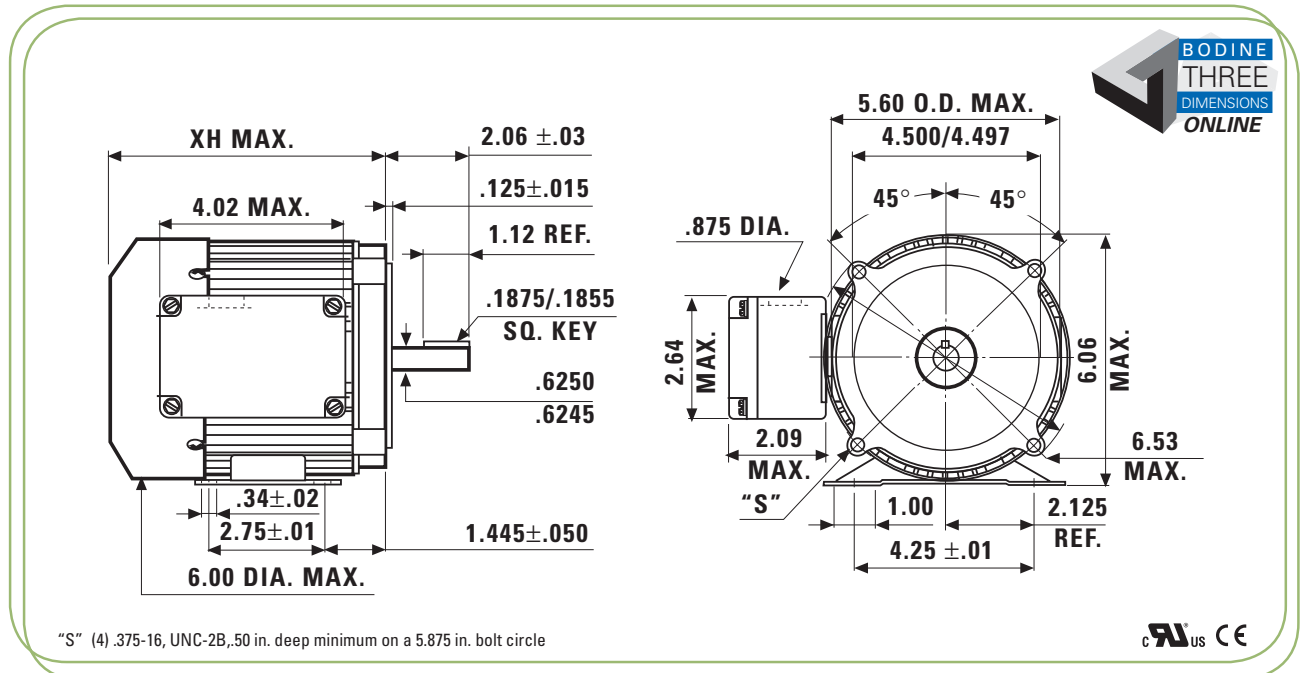

# Parallel Shaft AC Gearmotors

Up to 120 oz-in. continuous



## Standard Features

- Totally enclosed, non-ventilated IP-20 rating
- Permanently lubricated, noise tested ball bearings
- Three-wire winding simplifies reversing circuitry
- Impedance protected to prevent current overload (gearmotor should not be stalled when powered up)
- Three winding types are available, see page 14 for typical performance curves
- Bronze sleeve bearings on output shaft for quietness
- Permanently lubricated gearing utilizing grease
- Helical pinion accurately cut on motor shaft for

- maximum strength and minimum noise
- Non-metallic helical primary gear for quietness
- Steel helical gearing on subsequent stages for quietness and high strength

## Application Information

- See page 64 for connection diagrams
- Capacitor is included with motor
- Face mounting is standard

Speed (rpm)	Rated Torque (oz-in.)	Motor HP	V	Hz	Ph	A	Gear Ratio	Radial Load (oz.)	Length XH (inch)	Weight (lbs.)	Connection Diagram	Capacitor Part No.	Product Type	Model Number <sup>1</sup>
<b>Permanent Split Capacitor normal slip, Non-synchronous</b>														
0.9	120	1/700	115	60	1	.070	1800	20	2.54	2.2	074 10019	494 00045	KCI-22T5	N0727
1.9	100	1/700	115	60	1	.070	900	20	2.54	2.2	074 10019	494 00045	KCI-22T5	<b>0726</b>
5.6	95	1/700	115	60	1	.070	300	20	2.54	2.2	074 10019	494 00045	KCI-22T4	<b>0724</b>
9.0	95	1/700	115	60	1	.070	180	20	2.54	2.2	074 10019	494 00045	KCI-22T4	<b>0723</b>
13	95	1/450	115	60	1	.083	120	20	2.67	2.4	074 10019	494 00046	KCI-23T4	<b>0722</b>
22	95	1/300	115	60	1	.110	72	20	3.02	2.7	074 10019	494 00048	KCI-24T4	<b>0733</b>
26	80	1/300	115	60	1	.110	60	20	3.02	2.7	074 10019	494 00048	KCI-24T3	<b>0732</b>
52	34	1/450	115	60	1	.083	30	20	2.51	2.3	074 10019	494 00046	KCI-23A2	<b>0719</b>
52	59	1/300	115	60	1	.110	30	20	2.87	2.6	074 10019	494 00048	KCI-24A2	<b>0731</b>
86	21	1/450	115	60	1	.083	18	20	2.51	2.3	074 10019	494 00046	KCI-23A2	<b>0718</b>
86	35	1/300	115	60	1	.110	18	20	2.87	2.6	074 10019	494 00048	KCI-24A2	<b>0730</b>
130	24	1/300	115	60	1	.110	12	20	2.87	2.6	074 10019	494 00048	KCI-24A2	<b>0729</b>
260	12	1/300	115	60	1	.110	6	20	2.87	2.6	074 10019	494 00048	KCI-24A2	<b>0728</b>
<b>Permanent Split Capacitor High Slip, Non-synchronous</b>														
0.9	120	1/1000	115	60	1	.072	1800	20	2.54	2.2	074 10019	494 00045	KCI-22T5	N0746
2.3	95	1/1000	115	60	1	.072	600	20	2.54	2.2	074 10019	494 00045	KCI-22T5	<b>0744</b>
4.9	95	1/1000	115	60	1	.072	300	20	2.54	2.2	074 10019	494 00045	KCI-22T4	<b>0743</b>
10	88	1/800	115	60	1	.083	120	20	2.67	2.4	074 10019	494 00046	KCI-23T4	<b>0741</b>
20	80	1/450	115	60	1	.100	60	20	3.02	2.7	074 10019	494 00047	KCI-24T3	<b>0750</b>
40	44	1/450	115	60	1	.100	30	20	2.87	2.6	074 10019	494 00047	KCI-24A2	<b>0749</b>
67	16	1/800	115	60	1	.083	18	20	2.51	2.3	074 10019	494 00046	KCI-23A2	<b>0737</b>
67	27	1/450	115	60	1	.100	18	20	2.51	2.3	074 10019	494 00047	KCI-24A2	<b>0748</b>
200	8.9	1/450	115	60	1	.100	6	20	2.51	2.3	074 10019	494 00047	KCI-24A2	<b>0747</b>
<b>Permanent Split Capacitor, Synchronous</b>														
1.0	120	1/2000	115	60	1	.069	1800	20	2.54	2.2	074 10019	494 00045	KYC-22T5	N0767
3.0	88	1/2000	115	60	1	.069	600	20	2.54	2.2	074 10019	494 00045	KYC-22T5	<b>0765</b>
10.0	72	1/900	115	60	1	.093	180	20	3.02	2.7	074 10019	494 00048	KYC-24T4	<b>0776</b>
15.0	20	1/2000	115	60	1	.069	120	20	2.54	2.2	074 10019	494 00045	KYC-22T4	N0762
15.0	48	1/900	115	60	1	.093	120	20	3.02	2.7	074 10019	494 00048	KYC-24T4	N0775
25.0	29	1/900	115	60	1	.093	72	20	3.02	2.7	074 10019	494 00048	KYC-24T4	<b>0774</b>
60.0	15	1/900	115	60	1	.093	30	20	2.87	2.6	074 10019	494 00048	KYC-24A2	<b>0772</b>
100	8.9	1/900	115	60	1	.093	18	20	2.87	2.6	074 10019	494 00048	KYC-24A2	<b>0771</b>

<sup>1</sup> NOTE: Model numbers shown in bold type are in stock. "N" model numbers require lead time and minimum quantities.

## K-2 AC Gearmotor

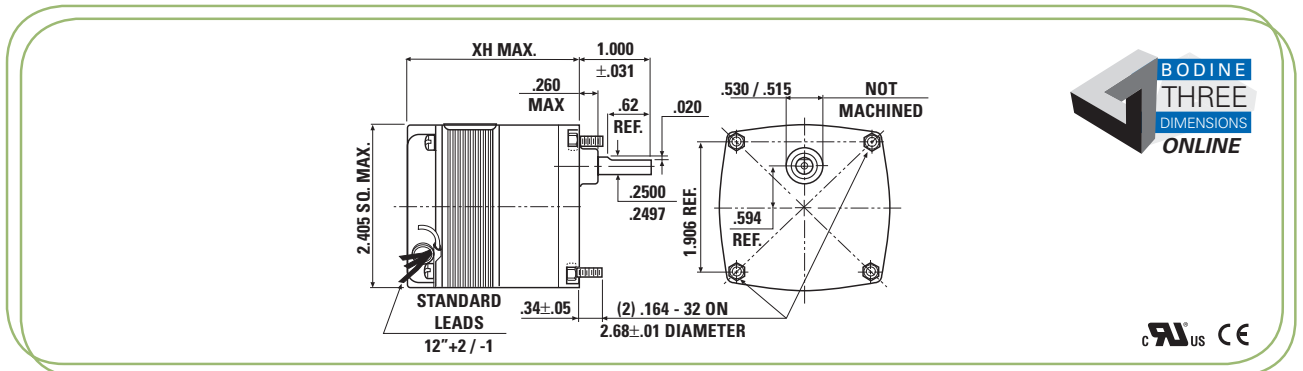

**BODINE**  
ELECTRIC  
COMPANY

MADE IN U.S.A.

New e-TORQ™ INTEGRAMOTOR™ Hollow Shaft Custom Pacemaker™ Inverter Duty AC Induction Permanent Magnet DC Brushless DC Index

# Parallel Shaft AC Gearmotors

Up to 40 lb-in. continuous

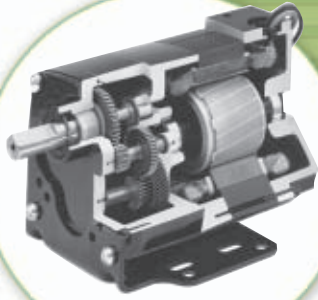

30R-D

FOR INVERTER DUTY MODELS



SEE PAGES 24-42

### Standard Features

- Totally Enclosed, Non-Ventilated IP-20 rating
- Class B insulation system
- Aluminum endshields for high thermal efficiency and light weight
- Unvented gearhousing for universal horizontal mounting
- Industrial lip type seals on motor and output shafts
- Needle bearings on output shaft for increased radial load capacity and long life
- Permanently lubricated with high-performance lubricant
- Reinforced thermoplastic helical primary gear for quietness and hardened steel spur gearing on subsequent stages for high output torque and long life
- Helical pinion accurately cut on motor shaft for maximum strength and minimum noise

### Application Information

- See page 64 for connection diagrams
- Capacitor is not included. Order with motor, see page 63
- Face mounting is standard

### Optional Accessories

- Die cast terminal box kit model 5982, achieves IP-44 rating, see page 62
- "L" bracket kit model 5968 permits base, ceiling and sidewall mounting, see page 62

Speed (rpm)	Rated Torque (lb-in.)	Motor HP	V	Hz	Ph	A	Gear Ratio	Radial Load (lbs.)	Length XH (inch)	Weight (lbs.)	Connection Diagram	Capacitor Part No.	Product Type	Model Number
<b>Permanent Split Capacitor, Non-synchronous</b>														
3.8	40	1/50	115	60	1	.33	450	65	5.23	5.8	074 10297	494 26812	30R1BECI-D5	5463
9.4	40	1/50	115	60	1	.33	180	65	5.23	5.8	074 10296	494 26812	30R1BECI-D4	5462
19	40	1/50	115	60	1	.33	90	65	5.23	5.8	074 10296	494 26812	30R1BECI-D4	5461
28	40	1/30	115	60	1	.45	60	65	5.48	6.3	074 10297	494 01015	30R2BECI-D3	5474
57	27	1/30	115	60	1	.45	30	65	5.48	6.3	074 10297	494 01015	30R2BECI-D3	5473
94	16	1/30	115	60	1	.45	18	65	5.48	6.3	074 10297	494 01015	30R2BECI-D3	5472
140	11	1/30	115	60	1	.45	12	65	5.48	6.3	074 10297	494 01015	30R2BECI-D3	5471
285	5	1/30	115	60	1	.45	6	65	5.48	6.3	074 10297	494 01015	30R2BECI-D3	5470

30R-D Gearmotor shown with optional "L" bracket (model 5968)

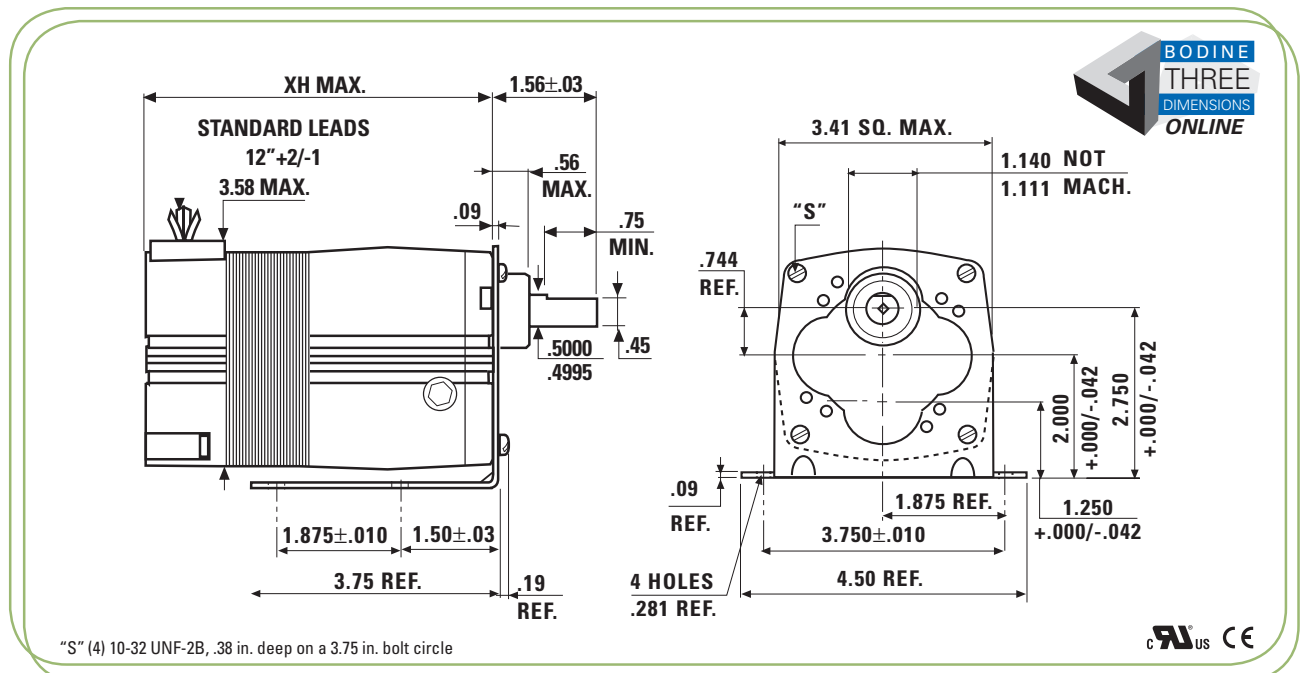

# Parallel Shaft AC Gearmotors

Up to 100 lb-in. continuous

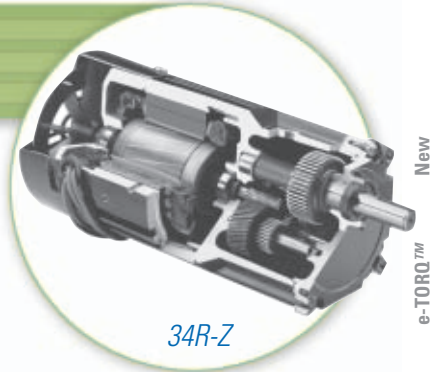

34R-Z

### Standard Features

- Totally enclosed IP-20 rating
- Fan cooled for high output power
- Class B insulation system operated within Class A limits to prolong winding and lubricant life
- Aluminum center ring and endshields for high thermal efficiency and light weight
- Unvented gearhousing for universal horizontal mounting
- Industrial lip type seals on motor and output shafts
- Needle bearings on output shaft for increased radial load capacity and long life
- Permanently lubricated with high-performance lubricant
- Wide reinforced thermoplastic helical primary gear for quietness and hardened steel spur gearing on subsequent stages for high output torque and long life
- Helical pinion accurately cut on motor shaft for maximum strength and minimum noise

### Application Information

- See page 64 for connection diagrams
- Capacitor is not included. Order with motor, see page 63
- Face mounting is standard
- Motors operate satisfactorily on 115 V, 50 Hz

### Optional Accessories

- Die cast terminal box kit model 0984,1984 achieves IP-44 rating, see page 62
- "L" bracket kit model 0980 permits base, ceiling, and sidewall mounting, see page 62

FOR INVERTER DUTY MODELS



SEE PAGES 24-42

Speed (rpm)	Rated Torque (lb-in.)	Motor HP	V	Hz	Ph	A	Gear Ratio	Radial Load (lbs.)	Length XH (inch)	Weight (lbs.)	Connection Diagram	Capacitor Part No.	Product Type	Model Number
<b>Permanent Split Capacitor, Non-synchronous</b>														
9.4	100	1/15	115	60	1	1.0	180	125	8.54	9.3	074 10296	494 01054	34R4BFCI-Z4	0449
19	100	1/15	115	60	1	1.0	90	125	8.54	9.3	074 10296	494 01054	34R4BFCI-Z4	0448
28	100	1/15	115	60	1	1.0	60	125	8.54	9.3	074 10297	494 01054	34R4BFCI-Z3	0455
57	56	1/15	115	60	1	1.0	30	125	8.54	9.3	074 10297	494 01054	34R4BFCI-Z3	0454
94	36	1/15	115	60	1	1.0	18	100	7.64	9.3	074 10296	494 01054	34R4BFCI-Z2	0453
142	24	1/15	115	60	1	1.0	12	100	7.64	9.3	074 10296	494 01054	34R4BFCI-Z2	0452
283	12	1/15	115	60	1	1.0	6	100	7.64	9.3	074 10296	494 01054	34R4BFCI-Z2	0451

34R-Z Gearmotor shown with optional "L" bracket (model 0980)

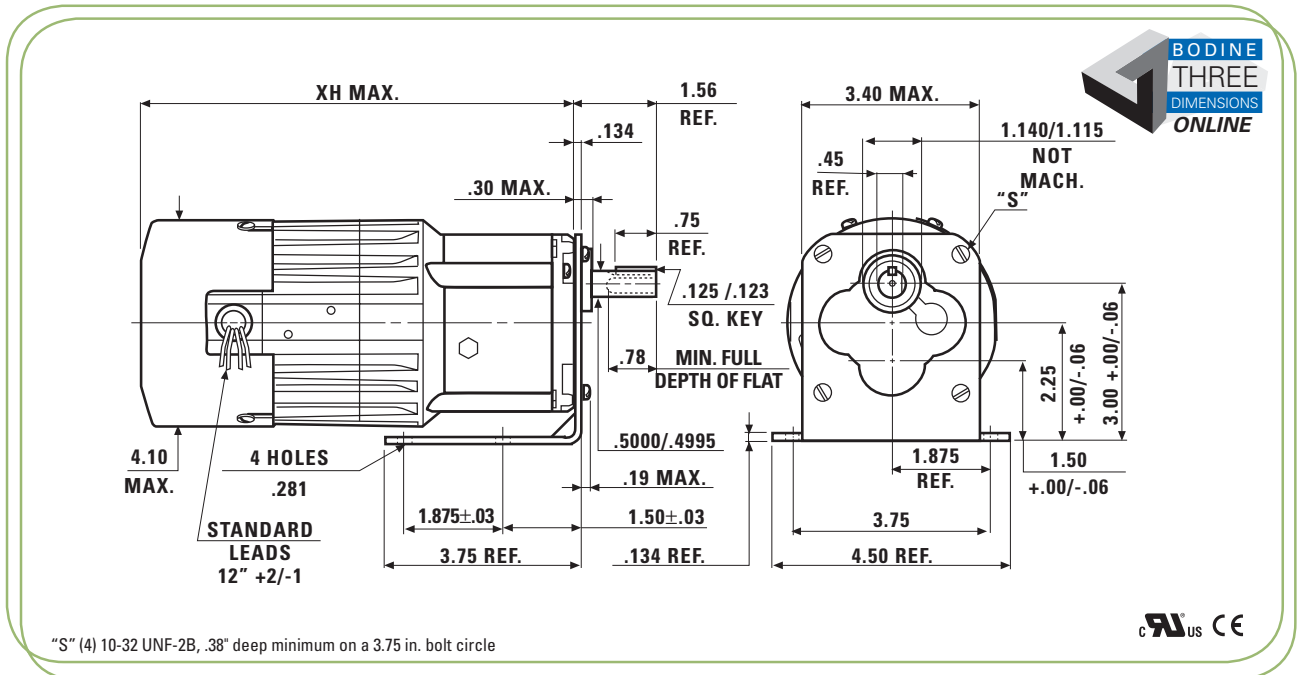

"S" (4) 10-32 UNF-2B, .38" deep minimum on a 3.75 in. bolt circle



MADE IN U.S.A.

New e-TORQ™ INTEGRAmotor™ Hollow Shaft Custom Pacemaker™ Inverter Duty AC Induction Permanent Magnet DC Brushless DC Index

# Parallel Shaft AC Gearmotors

Up to 200 lb-in. continuous

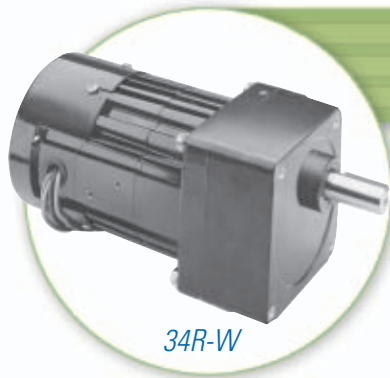

34R-W

### Standard Features

- Totally enclosed IP-20 rating
- Fan cooled for high output power
- Class B insulation system operated within Class A limits to prolong winding and lubricant life
- Aluminum center ring and endshields for high thermal efficiency and light weight
- Unvented gearhousing for universal horizontal mounting
- Industrial lip type seals on motor and output shafts
- Needle bearings on output shaft for increased radial load capacity and long life
- Permanently lubricated with high-performance lubricant
- Wide reinforced thermoplastic helical primary gear for quietness and hardened steel spur gearing on subsequent stages for high output torque and long life
- Helical pinion accurately cut on motor shaft for maximum strength and minimum noise

### Application Information

- See page 64 for connection diagrams
- Capacitor is not included. Order with motor, see page 63
- Face mounting is standard
- Motors operate satisfactorily on 115 V, 50 Hz

### Optional Accessories

- Die cast terminal box kit model 0984,1984 achieves IP-44 rating, see page 62
- "L" bracket kit model 0970 permits base, ceiling, and sidewall mounting, see page 62 or 73 for dimensions
- Adapter plate kit model 0995 provides for drop-in replacement of competitive gearmotors, see page 62

Speed (rpm)	Rated Torque (lb-in.)	Motor HP	V	Hz	Ph	A	Gear Ratio	Radial Load (lbs.)	Length XH (inch)	Weight (lbs.)	Connection Diagram	Capacitor Part No.	Product Type	Model No.
<b>Permanent Split Capacitor, Non-synchronous</b>														
5.4	175	1/15	115	60	1	1.0	312.4	130	8.20	10	074 10296	494 01054	34R4BFCI-W4	0477
9.9	166	1/15	115	60	1	1.0	172.1	130	8.20	10	074 10296	494 01054	34R4BFCI-W4	0476
17	154	1/9	115	60	1	1.4	97.5	130	9.20	12	074 10296	494 01006	34R6BFCI-W4	0485
26	146	1/9	115	60	1	1.4	65.5	130	9.20	12	074 10297	494 01006	34R6BFCI-W3	0484
39	108	1/9	115	60	1	1.4	43.9	130	9.20	12	074 10297	494 01006	34R6BFCI-W3	0483
57	73	1/9	115	60	1	1.4	29.7	130	9.20	12	074 10297	494 01006	34R6BFCI-W3	0482
83	53	1/9	115	60	1	1.4	20.4	65	9.20	12	074 10296	494 01006	34R6BFCI-W2	0481
123	36	1/9	115	60	1	1.4	13.8	65	9.20	12	074 10296	494 01006	34R6BFCI-W2	0480
181	24	1/9	115	60	1	1.4	9.4	65	9.20	12	074 10296	494 01006	34R6BFCI-W2	0479
310	14	1/9	115	60	1	1.4	5.5	65	9.20	12	074 10296	494 01006	34R6BFCI-W2	0478

### 34R-W Gearmotor

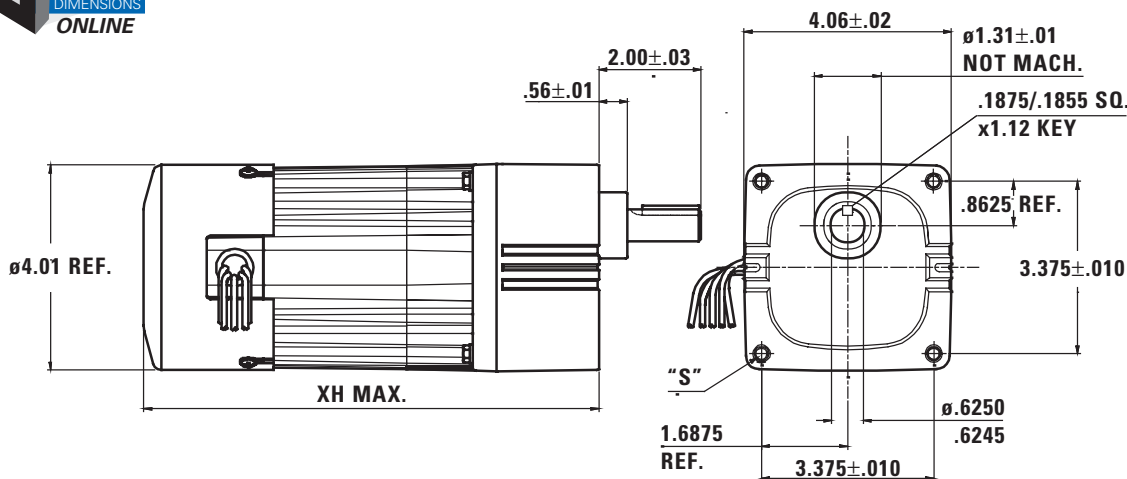

"S" (4) 1/4-28 UNF-2B .50" deep minimum on 4.78 in. bolt circle





# Parallel Shaft AC Gearmotors

Up to 341 lb-in. continuous

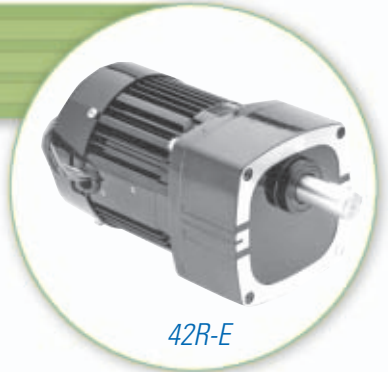

42R-E

FOR INVERTER DUTY MODELS  
**PACESSETTER**  
SEE PAGES 24-42

### Standard Features

- See page 47 for 42R motor information
- Unvented gearhousing for universal horizontal mounting
- Industrial lip type seals on motor and output shafts
- Needle bearings throughout for increased radial load capacity and long life
- Permanently lubricated with high-performance lubricant
- Selectively hardened helical gearing for quietness and high output to size ratio

### Application Information

- See page 64 for connection diagrams
- Capacitor is not included. Order with motor, see p. 61
- Face mounting is standard

### Optional Accessories

- Die cast terminal box kit model 0984,1984 achieves IP-44 rating, see page 62
- Stamped terminal box kit model 0982 see page 62
- "L" bracket kit model 0969 permits base, ceiling, and sidewall mounting, see page 62
- Adapter plate kit model 0995 provides for drop-in replacement of competitive gearmotors, see page 62

Speed (rpm)	Rated Torque (lb-in.)	Motor HP	V	Hz	Ph	A	Gear Ratio	Radial Load (lbs.)	Length XH (inch)	Weight (lbs.)	Connection Diagram	Capacitor Part No.	Product Type	Model Number
<b>Permanent Split Capacitor, Non-synchronous</b>														
5.7	310	1/12	115	60	1	1.2	300	200	8.02	12.0	074 10296	494 00031	42R3BFCI-E4	<b>0671</b>
9.4	341	1/12	115	60	1	1.2	180	200	8.02	12.0	074 10296	494 00031	42R3BFCI-E4	<b>0669</b>
14	290	1/12	115	60	1	1.2	120	200	8.02	12.0	074 10296	494 00031	42R3BFCI-E4	<b>0668</b>
28	270	1/6	115	60	1	1.9	60	200	9.08	14.5	074 10297	494 00034	42R5BFCI-E3	<b>0685</b>
57	135	1/6	115	60	1	1.9	30	300	9.08	14.5	074 10297	494 00034	42R5BFCI-E3	<b>0683</b>
85	90	1/6	115	60	1	1.9	20	300	9.08	14.5	074 10297	494 00034	42R5BFCI-E3	<b>0681</b>
170	45	1/6	115	60	1	1.9	10	300	9.08	14.5	074 10296	494 00034	42R5BFCI-E2	<b>0680</b>
340	25	1/6	115	60	1	1.9	5	300	9.08	14.5	074 10297	494 00034	42R5BFCI-E1	<b>0679</b>
<b>Split Phase (with centrifugal switch), Non-synchronous</b>														
5.7	310	1/12	115	60	1	2.4	300	200	8.02	12	074 10292	—	42R3BFISI-E4	<b>0639</b>
9.4	341	1/12	115	60	1	2.4	180	200	8.02	12	074 10292	—	42R3BFISI-E4	<b>0637</b>
14	277	1/12	115	60	1	2.4	120	200	8.02	12	074 10292	—	42R3BFISI-E4	<b>0636</b>
19	208	1/12	115	60	1	2.4	90	200	8.02	12	074 10292	—	42R3BFISI-E4	<b>0635</b>
28	270	1/6	115	60	1	3.6	60	200	9.08	14.5	074 10293	—	42R5BFISI-E3	<b>0655</b>
42	180	1/6	115	60	1	3.6	40	200	9.08	14.5	074 10293	—	42R5BFISI-E3	<b>0654</b>
57	135	1/6	115	60	1	3.6	30	300	9.08	14.5	074 10293	—	42R5BFISI-E3	<b>0653</b>
85	90	1/6	115	60	1	3.6	20	300	9.08	14.5	074 10293	—	42R5BFISI-E3	<b>0652</b>
115	68	1/6	115	60	1	3.6	15	300	9.08	14.5	074 10292	—	42R5BFISI-E2	<b>0651</b>
170	45	1/6	115	60	1	3.6	10	300	9.08	14.5	074 10292	—	42R5BFISI-E2	<b>0650</b>
340	25	1/6	115	60	1	3.6	5	300	9.08	14.5	074 10293	—	42R5BFISI-E1	<b>0649</b>
<b>Three-phase, Non-synchronous</b>														
28	270	1/4	230	60	3	1.2	60	200	9.08	14.5	074 10007	—	42R5BFPP-E3	<b>0667</b>
57	135	1/4	230	60	3	1.2	30	300	9.08	14.5	074 10007	—	42R5BFPP-E3	<b>0666</b>
170	45	1/4	230	60	3	1.2	10	300	9.08	14.5	074 10007	—	42R5BFPP-E2	<b>0665</b>

42R-E Gearmotor shown with optional "L" bracket (model 0969)

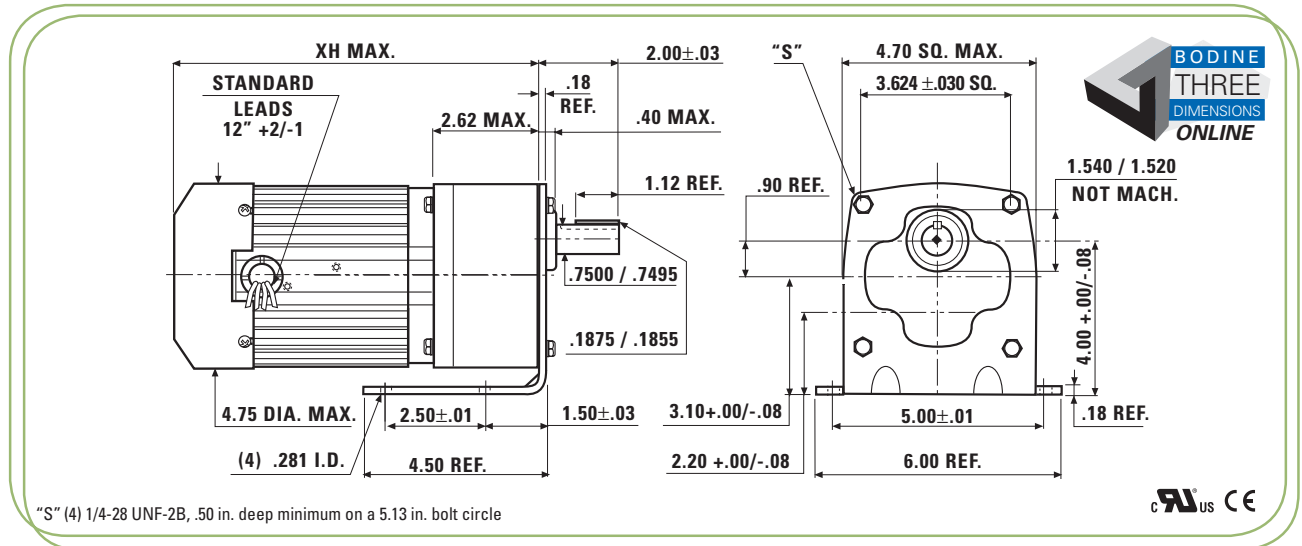

New  
e-TORQ™  
INTEGRAMOTOR™  
Hollow Shaft  
Custom  
Pacesetter™ Inverter Duty  
AC Induction  
Permanent Magnet DC  
Brushless DC  
Index

# Parallel Shaft AC Gearmotors

Up to 250 lb-in. continuous

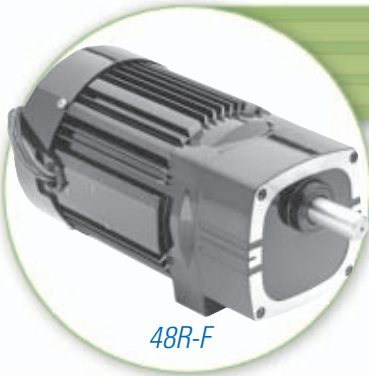

48R-F

FOR INVERTER DUTY MODELS



SEE PAGES 24-42

### Standard Features

- Totally enclosed IP-20 rating
- Fan cooled for high output power
- Class B insulation system operated within Class A limits to prolong winding and lubricant life
- Aluminum center ring and endshields for high thermal efficiency and light weight
- Unvented gearhousing for universal horizontal mounting
- Industrial lip type seals on motor and output shafts
- Needle bearings throughout for increased radial load capacity and long life
- Permanently lubricated with high-performance lubricant
- Hardened helical gearing for quietness and high output to size ratio

### Application Information

- See page 64 for connection diagrams
- Capacitor is not included. Order with motor, see page 63
- Face mounting is standard

### Optional Accessories

- Die cast terminal box kit model 0984,1984 achieves IP-44 rating, see page 62
- Steel terminal box kit model 0982 see page 62
- Rigid base kit model 0989 permits base mounting, see page 62
- Adapter plate kit model 0995 provides for drop-in replacement of competitive gearmotors, see page 62

Speed (rpm)	Rated Torque (lb-in.)	Motor HP	V	Hz	Ph	A	Gear Ratio	Radial Load (lbs.)	Length XH (inch)	Weight (lbs.)	Connection Diagram	Capacitor Part No. 115V/230V	Product Type	Model Number <sup>1</sup>
<b>Permanent Split Capacitor, Non-synchronous</b>														
57	250	1/3	115/230	60	1	4.0/2.0	30	300	10.47	26	074 10295	494 00035/ 494 00033	48R6BFCl-F3	<b>0694</b>
85	167	1/3	115/230	60	1	4.0/2.0	20	300	10.47	26	074 10295	494 00035/ 494 00033	48R6BFCl-F3	<b>0693</b>
113	162	1/3	115/230	60	1	4.0/2.0	15	300	10.47	26	074 10294	494 00035/ 494 00033	48R6BFCl-F2	N0695
170	108	1/3	115/230	60	1	4.0/2.0	10	300	10.47	26	074 10294	494 00035/ 494 00033	48R6BFCl-F2	<b>0692</b>
340	56	1/3	115/230	60	1	4.0/2.0	5	300	10.47	26	074 10295	494 00035/ 494 00033	48R6BFCl-F1	<b>0691</b>
<b>Split Phase (with centrifugal switch), Non-synchronous</b>														
57	250	1/3	115/230	60	1	4.8/2.4	30	300	10.47	26	074 10299	—	48R6BFSl-F3	<b>0664</b>
85	167	1/3	115/230	60	1	4.8/2.4	20	300	10.47	26	074 10299	—	48R6BFSl-F3	<b>0663</b>
17	108	1/3	115/230	60	1	4.8/2.4	10	300	10.47	26	074 10298	—	48R6BFSl-F2	<b>0662</b>
340	56	1/3	115/230	60	1	4.8/2.4	5	300	10.47	26	074 10299	—	48R6BFSl-F1	<b>0661</b>
<b>Three-phase, Non-synchronous</b>														
47/57	250	1/2	230/460	50/60	3	1.9/1.4/.95/.7	30	300	10.47	26	074 10012	—	48R6BFPP-F3	<b>0643</b>
70/85	167	1/2	230/460	50/60	3	1.9/1.4/.95/.7	20	300	10.47	2	074 10012	—	48R6BFPP-F3	<b>0642</b>
140/170	115	1/2	230/460	50/60	3	1.9/1.4/.95/.7	10	300	10.47	26	074 10012	—	48R6BFPP-F2	<b>0641</b>
280/340	58	1/2	230/460	50/60	3	1.9/1.4/.95/.7	5	300	10.47	26	074 10012	—	48R6BFPP-F1	N0640

<sup>1</sup> NOTE: Model numbers shown in bold type are in stock. "N" model numbers require lead time and minimum quantities.

48R-F Gearmotor shown with optional rigid base (model 0989)

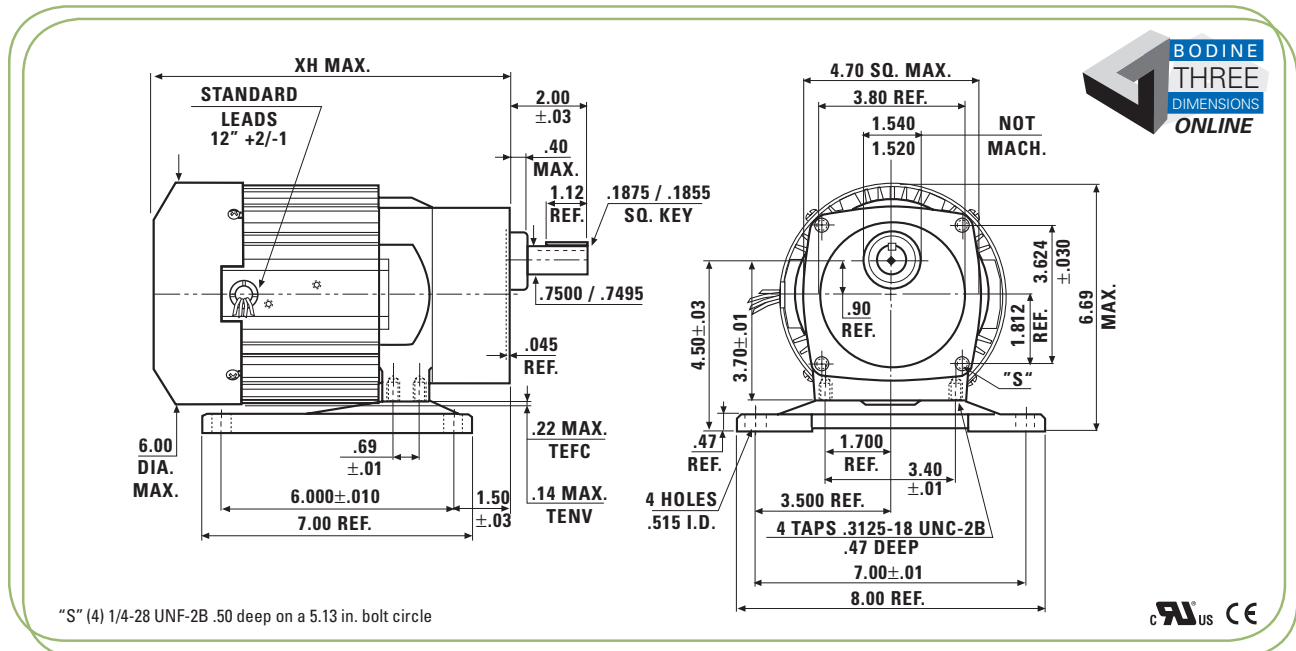

# Right Angle AC Gearmotors

Up to 37 lb-in. continuous



34R-3F

FOR INVERTER DUTY MODELS



SEE PAGES 24-42

### Standard Features

- Totally enclosed IP-20 rating
- Fan cooled for high output power
- Class B insulation system operated within Class A limits to prolong winding and lubricant life
- Aluminum center ring and endshields for high thermal efficiency and light weight
- Industrial lip type seals on motor and output shafts
- Bronze sleeve bearings on output shaft oiled by felt wicks and reservoir for quietness
- Permanently lubricated with high-performance lubricant
- Bronze worm gear for high shock load capability
- Hardened and ground worm for strength and long life

### Application Information

- See page 64 for connection diagrams
- Capacitor is not included. Order with motor, see page 63
- Mounting is via four tapped holes in the bottom of the gearhead
- Motors operate satisfactorily on 115 V, 50 Hz
- Hollow shaft configurations are available. See Web site for mounting and shaft details. These models require lead time and minimum quantities.

### Optional Accessories

- Die cast terminal box kit model 0984,1984 achieves IP-44 rating, see page 62
- Gearhead baseplate kit model 0967 shown on page 62

Speed (rpm)	Rated Torque (lb-in.)	Motor HP	V	Hz	Ph	A	Gear Ratio	Radial Load (lbs.)	Length XH (inch)	Weight (lbs.)	Connection Diagram	Capacitor Part No.	Product Type	Model No.
<b>Permanent Split Capacitor, Non-synchronous</b>														
28	37	1/15	115	60	1	1.0	60	40	8.69	9.3	074 10296	494 01054	34R4BFCI-3F	<b>0492</b>
43	37	1/15	115	60	1	1.0	40	40	8.69	9.3	074 10296	494 01054	34R4BFCI-3F	<b>0491</b>
57	30	1/15	115	60	1	1.0	30	40	8.69	9.3	074 10296	494 01054	34R4BFCI-3F	<b>0487</b>
85	27	1/15	115	60	1	1.0	20	40	8.69	9.3	074 10296	494 01054	34R4BFCI-3F	<b>0490</b>
113	20	1/15	115	60	1	1.0	15	5	8.69	9.3	074 10296	494 01054	34R4BFCI-3F	<b>0489</b>
170	16	1/15	115	60	1	1.0	10	5	8.69	9.3	074 10296	494 01054	34R4BFCI-3F	<b>0488</b>

34R-3F Gearmotor shown with optional baseplate kit (model 0967)

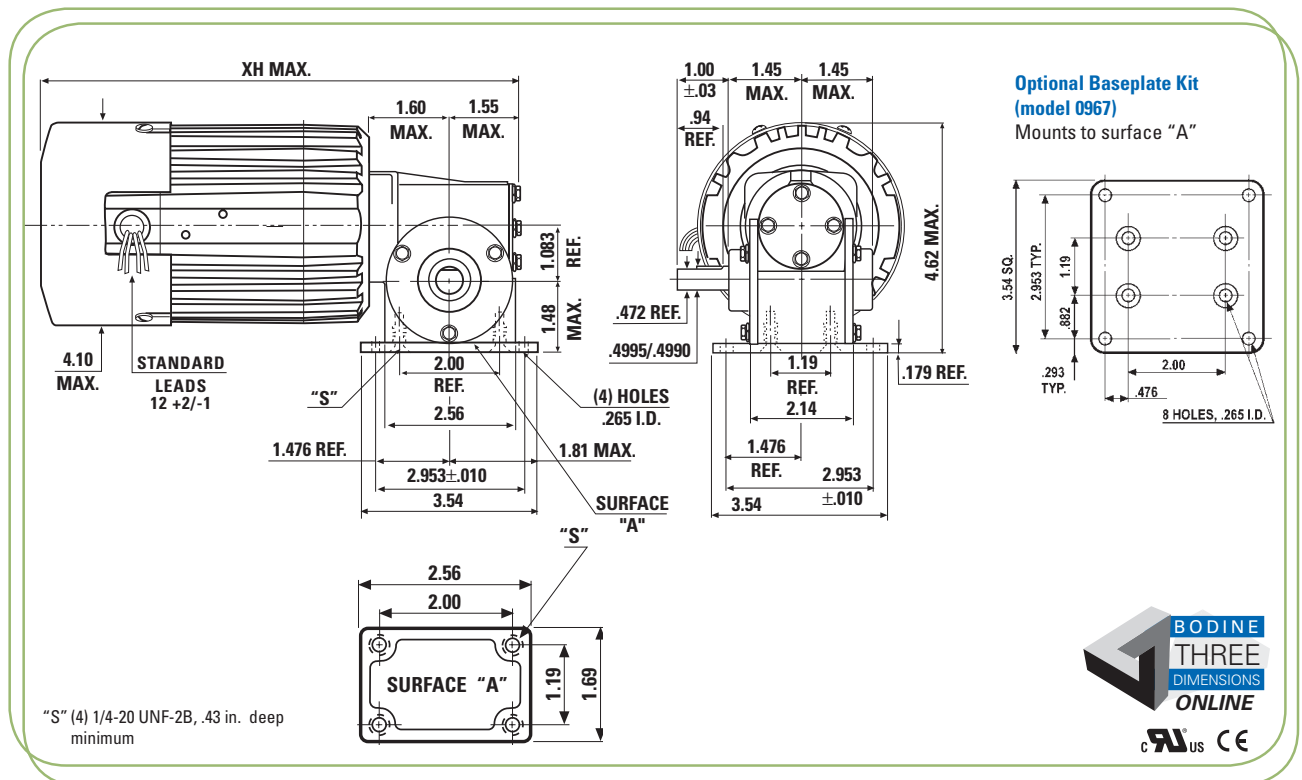

# Right Angle AC Gearmotors

Up to 121 lb-in. continuous



34R-5F

### Standard Features

- Totally enclosed IP-20 rating
- Fan cooled for high output power
- Class B insulation system operated within Class A limits to prolong winding and lubricant life
- Aluminum center ring and endshields for high thermal efficiency and light weight
- Unvented gearhousing for universal horizontal mounting
- Industrial lip type seals on motor and output shafts
- Bronze sleeve bearings on output shaft oiled by felt wicks and reservoir for quietness
- Permanently lubricated with high-performance lubricant
- Bronze worm gear for high shock load capability
- Hardened and ground worm for strength and long life

### Application Information

- See page 64 for connection diagrams
- Capacitor is not included. Order with motor, see page 63
- Mounting is via four feet on the gearhead
- Hollow shaft configurations are available. See Web site for mounting and shaft details. These models require lead time and minimum quantities.

### Optional Accessories

- Die cast terminal box kit model 0984,1984 achieves IP-44 rating, see page 62

Speed 50/60 Hz (rpm)	Rated Torque 50/60 Hz (lb-in.)	Motor HP	V	Hz	Ph	A 50/60 Hz	Gear Ratio	Radial Load (lbs.)	Length XH (inch)	Weight (lbs.)	Connection Diagram	Capacitor Part No.	Product Type	Model No. <sup>1</sup>
<b>Permanent Split Capacitor, Non-synchronous</b>														
19/23	121/102	1/9	115	50/60	1	1.8/1.4	75	80	10.38	12.0	074 10296	494 01006	34R6BFCl-5F	<b>0524</b>
23/28	111/93	1/9	115	50/60	1	1.8/1.4	60	80	10.38	12.0	074 10296	494 01006	34R6BFCl-5F	N0523
28/34	104/87	1/9	115	50/60	1	1.8/1.4	50	80	10.38	12.0	074 10296	494 01006	34R6BFCl-5F	N0522
35/43	93/78	1/9	115	50/60	1	1.8/1.4	40	80	10.38	12.0	074 10296	494 01006	34R6BFCl-5F	<b>0521</b>
47/57	83/70	1/9	115	50/60	1	1.8/1.4	30	80	10.38	12.0	074 10296	494 01006	34R6BFCl-5F	N0519
70/85	60/50	1/9	115	50/60	1	1.8/1.4	20	80	10.38	12.0	074 10296	494 01006	34R6BFCl-5F	<b>0518</b>
93/113	45/37	1/9	115	50/60	1	1.8/1.4	15	80	10.38	12.0	074 10296	494 01006	34R6BFCl-5F	N0514
140/170	35/29	1/9	115	50/60	1	1.8/1.4	10	80	10.38	12.0	074 10296	494 01006	34R6BFCl-5F	<b>0513</b>
280/340	19/16	1/9	115	50/60	1	1.8/1.4	5	80	10.38	12.0	074 10296	494 01006	34R6BFCl-5F	N0511

<sup>1</sup> NOTE: Model numbers shown in bold type are in stock. "N" model numbers require lead time and minimum quantities.

### 34R-5F Gearmotor

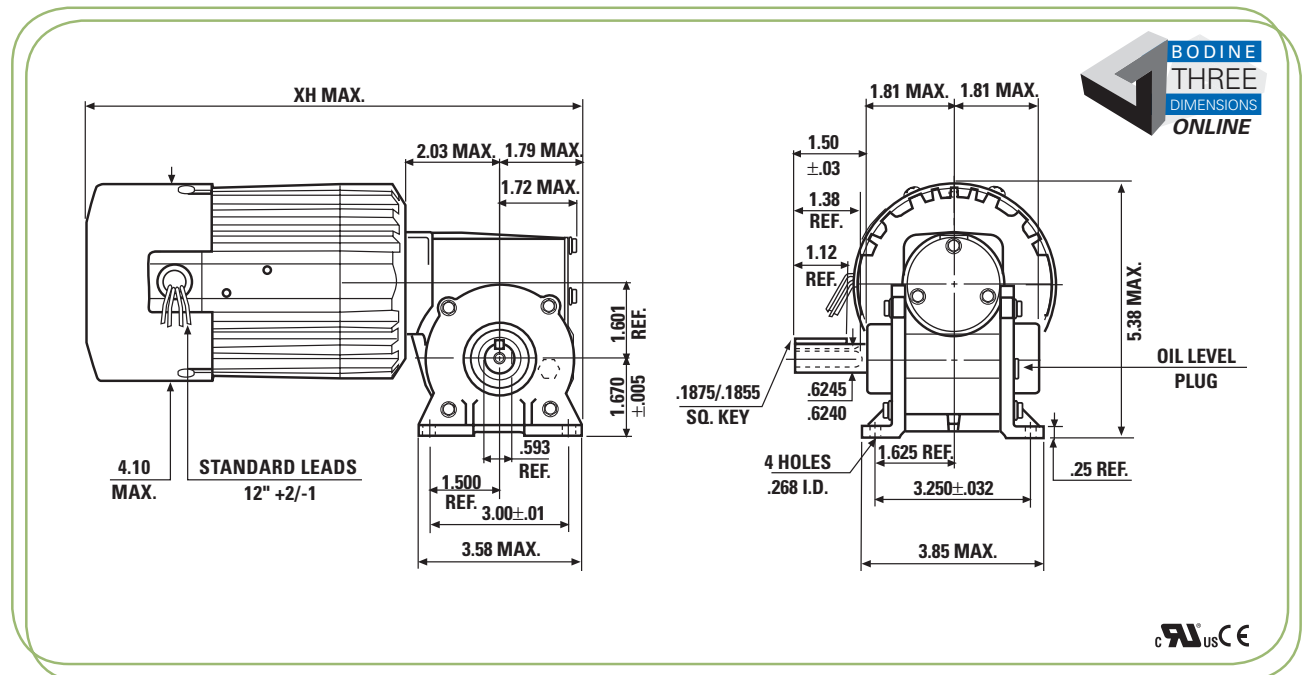

# Right Angle AC Gearmotors

Up to 113 lb-in. continuous

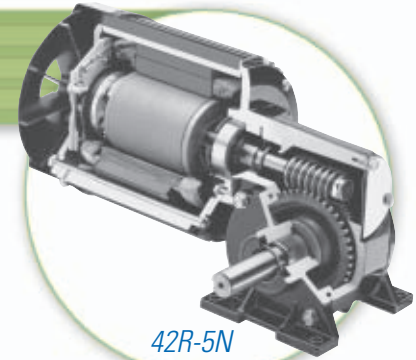

42R-5N

FOR INVERTER DUTY MODELS



SEE PAGES 24-42

### Standard Features

- Totally enclosed IP-20 rating
- Fan cooled for high output power
- Class B insulation system operated within Class "A" limits to prolong winding and lubricant life
- Aluminum center ring and endshields for high thermal efficiency and light weight
- Unvented gearhousing for universal horizontal mounting
- Industrial lip type seals on motor and output shafts
- Needle bearings throughout for increased radial load capacity and long life
- Permanently lubricated with high-performance lubricant
- Bronze worm gear for high shock load capability
- Hardened and ground worm for strength and long life

### Application Information

- See page 64 for connection diagrams.
- Capacitor is not included. Order with motor, see page 63
- Mounting is via four feet on the gearhead
- Hollow shaft configurations are available. See Web site for mounting and shaft details. These models require lead time and minimum quantities.

### Optional Accessories

- Die cast terminal box kit model 0984,1984 achieves IP-44 rating, see page 62
- Stamped terminal box kit model 0982 shown on page 62

Speed (rpm)	Rated Torque (lb-in.)	Motor HP	V	Hz	Ph	A	Gear Ratio	Radial Load (lbs.)	Length XH (inch)	Weight (lbs.)	Connection Diagram	Capacitor Part No.	Product Type	Model Number
<b>Permanent Split Capacitor, Non-synchronous</b>														
38	113	1/6	115	60	1	2.1	40	180	10.25	15.5	074 10296	494 00034	42R5BFCl-5N	0678
75	81	1/6	115	60	1	2.1	20	180	10.25	15.5	074 10296	494 00034	42R5BFCl-5N	0677
150	47	1/6	115	60	1	2.1	10	180	10.25	15.5	074 10296	494 00034	42R5BFCl-5N	0672
300	25	1/6	115	60	1	2.1	5	180	10.25	15.5	074 10296	494 00034	42R5BFCl-5N	0670
<b>Split Phase (with centrifugal switch), Non-synchronous</b>														
43	113	1/6	115	60	1	3.6	40	180	10.25	15.5	074 10292	—	42R5BFSl-5N	0648
85	75	1/6	115	60	1	3.6	20	180	10.25	15.5	074 10292	—	42R5BFSl-5N	0647
170	43	1/6	115	60	1	3.6	10	180	10.25	15.5	074 10292	—	42R5BFSl-5N	0646
340	23	1/6	115	60	1	3.6	5	180	10.25	15.5	074 10292	—	42R5BFSl-5N	0645
<b>Three-phase, Non-synchronous</b>														
43	113	1/4	230	60	3	1.2	40	180	10.25	15.5	074 10007	—	42R5BFPP-5N	0634
85	75	1/4	230	60	3	1.2	20	180	10.25	15.5	074 10007	—	42R5BFPP-5N	0633
170	67	1/4	230	60	3	1.2	10	180	10.25	15.5	074 10007	—	42R5BFPP-5N	0630
340	36	1/4	230	60	3	1.2	5	180	10.25	15.5	074 10007	—	42R5BFPP-5N	0629

### 42R-5N Gearmotor

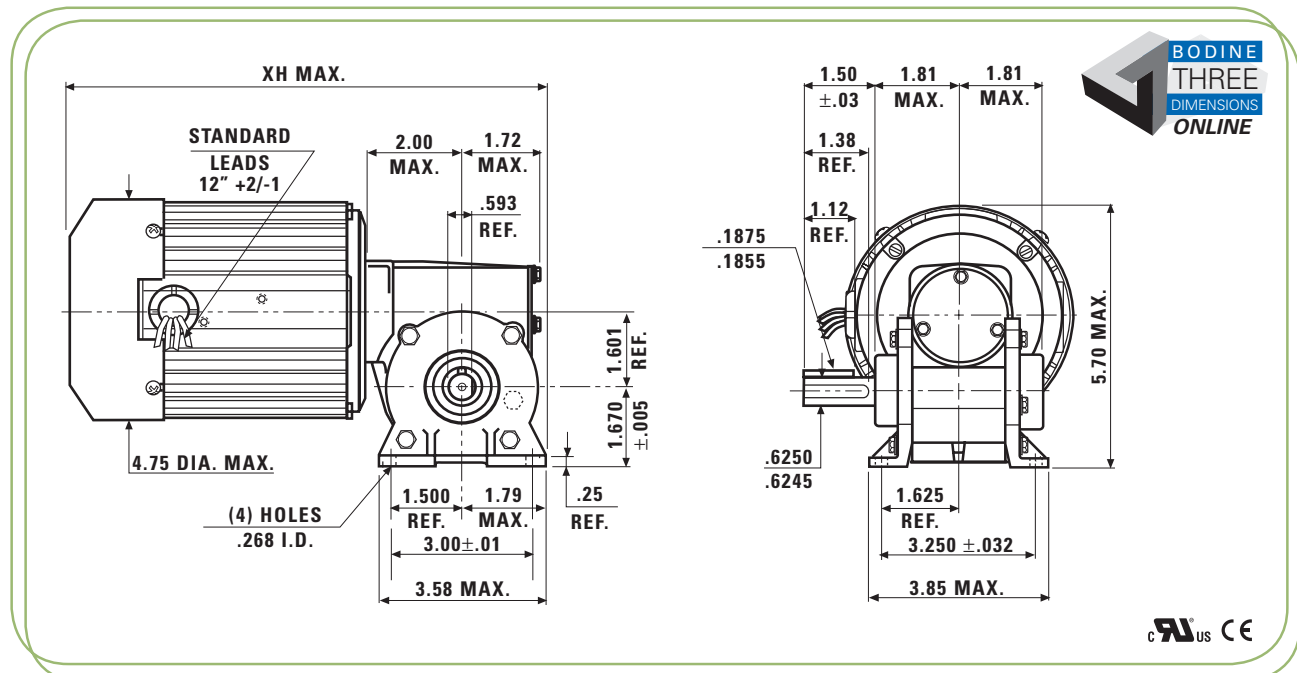

MADE IN U.S.A.

New e-TORQ™ INTEGRAmotor™ Hollow Shaft Custom Pacesetter™ Inverter Duty AC Induction Permanent Magnet DC Brushless DC Index

# Right Angle AC Gearmotors

Up to 77 lb-in. continuous



34R-5R and  
42R-5L

### Product Description

Based on our 5R gearhead, these sturdy single reduction worm gearmotors are designed for transmitting relatively substantial torque. The separable, hardened and ground, steel worm is key-slot and tongue driven. This gearhead is oil lubricated for life, and equipped with a bronze worm gear for quiet operation.

### Standard Features

- Designed as bolt-in replacements for N-type gearmotors
- Die cast shield and gear housing
- Shielded ball bearings on motor shaft
- Separable worm
- Unvented gearhousing for universal horizontal mounting
- Permanently lubricated with high-performance lubricant
- Supplied with base mounted to motor

Speed (rpm)	Rated Torque (lb-in.)	Motor HP	V	Hz	Ph	A	Gear Ratio	Radial Load (lbs.)	Length XH (inch)	Weight (lbs.)	Connection Diagram	Capacitor Part No.	Product Type	Model Number <sup>1</sup>
<b>34R4-5R, Permanent Split Capacitor, Non-synchronous, 115VAC, 50/60Hz, 1-Phase, Class B (TEFC)</b>														
29	33	1/15	115	60	1	1.0	60	50	9.29	11.5	074 10005*	494 01054	34R4BFCI-5R	<b>0469</b>
43	49	1/15	115	60	1	1.0	40	50	9.29	11.5	074 10005*	494 01054	34R4BFCI-5R	<b>0468</b>
86	32	1/15	115	60	1	1.0	20	50	9.29	11.5	074 10005*	494 01054	34R4BFCI-5R	<b>0466</b>
170	18	1/15	115	60	1	1.0	10	30	9.29	11.5	074 10005*	494 01054	34R4BFCI-5R	<b>0465</b>
<b>42R4-5L, Permanent Split Capacitor, Non-synchronous, 115VAC, 60Hz, 1-Phase, Class B (TEFC)</b>														
43	77	1/8	115	60	1	1.7	40	80	9.69	13.5	074 10005*	494 01006	42R4BFCI-5L	<b>0627</b>
57	75	1/8	115	60	1	1.7	30	80	9.69	13.5	074 10005*	494 01006	42R4BFCI-5L	<b>0626</b>
85	54	1/8	115	60	1	1.7	20	80	9.69	13.5	074 10005*	494 01006	42R4BFCI-5L	<b>0624</b>
170	31	1/8	115	60	1	1.7	10	10	9.69	13.5	074 10005*	494 01006	42R4BFCI-5L	<b>0623</b>
<b>42R4-5L, Split Phase, Non-synchronous, 115VAC, 60Hz, 1-Phase, Class B (TEFC)</b>														
43	77	1/8	115	60	1	3.0	40	80	9.69	13.5	074 10292	NONE	42R4BFSI-5L	<b>0620</b>
57	75	1/8	115	60	1	3.0	30	80	9.69	13.5	074 10292	NONE	42R4BFSI-5L	<b>0619</b>
85	54	1/8	115	60	1	3.0	20	80	9.69	13.5	074 10292	NONE	42R4BFSI-5L	<b>0618</b>
170	31	1/8	115	60	1	3.0	10	10	9.69	13.5	074 10292	NONE	42R4BFSI-5L	<b>0617</b>

<sup>1</sup> NOTE: Model numbers shown in bold type are in stock. "N" model numbers require lead time and minimum quantities.

\* Alternate connection diagram 074 10296

### 34R-5R and 42R-5L Gearmotors

#### 34R-5R Gearmotor

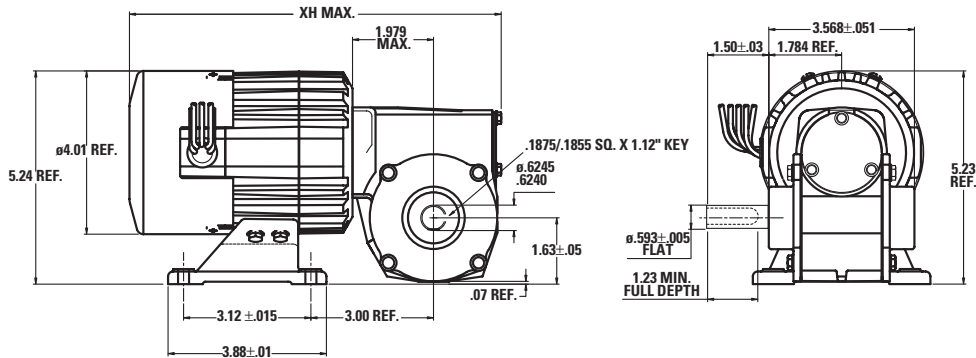

#### 42R-5L Gearmotor

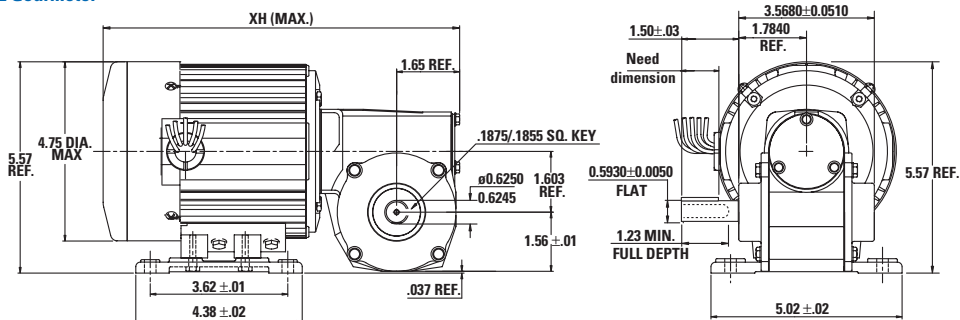

# Right Angle AC Gearmotors

Up to 380 lb-in. continuous

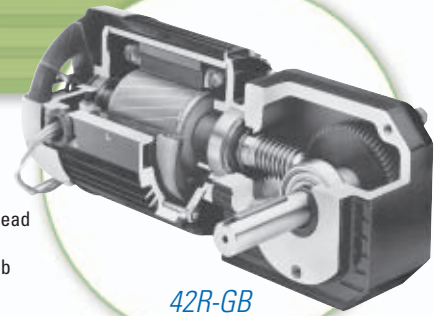

42R-GB

### Standard Features

- Totally enclosed IP-20 rating
- Fan cooled for high output power
- Class B insulation system operated within Class A limits to prolong winding and lubricant life
- Aluminum center ring and endshields for high thermal efficiency and light weight
- Unvented gearhousing for universal horizontal mounting
- Industrial lip type seals on motor and output shafts
- Ball bearings throughout for increased radial load capacity and long life
- Permanently lubricated with high-performance lubricant
- Hardened helical output gearing for quietness and high output torque
- Bronze worm gear for high shock load capability
- Hardened and ground worm hobbled on the motor shaft for high strength and long life

### Application Information

- See page 64 for connection diagrams
- Capacitor is not included. Order with motor, see page 63
- Mounting is via four tapped holes under the gearhead or three tapped holes in the face of the gearhead
- Hollow shaft configurations are available. See Web site for mounting and shaft details. These models require lead time and minimum quantities.

### Optional Accessories

- Die cast terminal box kit model 0984,1984 achieves IP-44 rating see page 62
- Stamped terminal box kit model 0982 shown on page 62

FOR INVERTER DUTY MODELS



SEE PAGES 24-42

Speed (rpm)	Rated Torque (lb-in.)	Motor HP	V	Hz	Ph	A	Gear Ratio	Radial Load (lbs.)	Length XH (inch)	Weight (lbs.)	Connection Diagram	Capacitor Part No.	Product Type	Model Number <sup>1</sup>
<b>Permanent Split Capacitor, Non-synchronous</b>														
5.9	380	1/6	115	60	1	1.9	280	200	11.57	17.5	074 10297	494 28281	42R5BFCl-GB	<b>5266</b>
8.9	375	1/6	115	60	1	1.9	190	200	11.57	17.5	074 10297	494 28281	42R5BFCl-GB	N5264
14	290	1/6	115	60	1	1.9	120	200	11.57	17.5	074 10297	494 28281	42R5BFCl-GB	<b>5262</b>
21	278	1/6	115	60	1	1.9	80	200	11.57	17.5	074 10297	494 28281	42R5BFCl-GB	N5261
28	209	1/6	115	60	1	1.9	60	200	11.57	17.5	074 10297	494 28281	42R5BFCl-GB	<b>5260</b>
<b>Three-phase, Non-synchronous</b>														
5.9	380	1/4	230/460	60	3	1.2/0.6	280	200	11.57	17.5	074 10103	—	42R5BFPP-GB	N5276
8.9	375	1/4	230/460	60	3	1.2/0.6	190	200	11.57	17.5	074 10103	—	42R5BFPP-GB	N5274
14	290	1/4	230/460	60	3	1.2/0.6	120	200	11.57	17.5	074 10103	—	42R5BFPP-GB	N5272
21	307	1/4	230/460	60	3	1.2/0.6	80	200	11.57	17.5	074 10103	—	42R5BFPP-GB	N5271
28	230	1/4	230/460	60	3	1.2/0.6	60	200	11.57	17.5	074 10103	—	42R5BFPP-GB	N5270

<sup>1</sup> NOTE: Model numbers shown in bold type are in stock. "N" model numbers require lead time and minimum quantities.

### 42R-GB Gearmotor

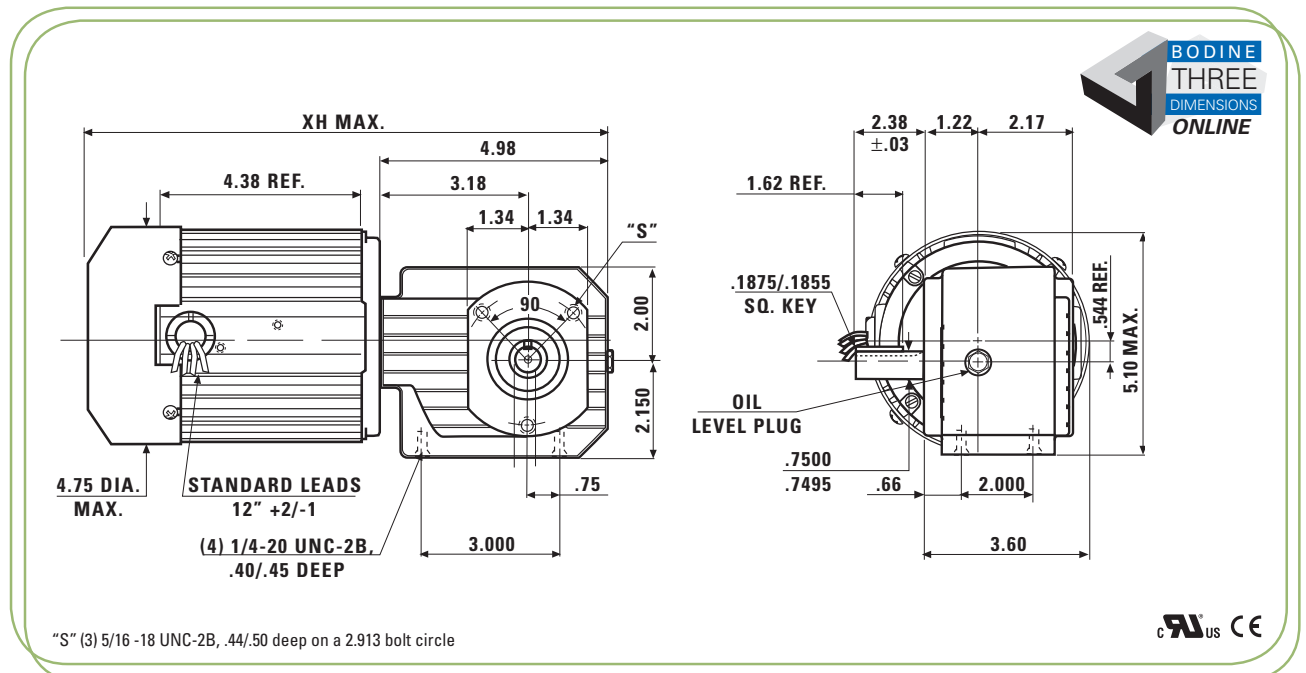

"S" (3) 5/16 -18 UNC-2B, .44/.50 deep on a 2.913 bolt circle



MADE IN U.S.A.

New e-TORQ™ INTEGRAmotor™ Hollow Shaft Custom Pacemaker™ Inverter Duty AC Induction Permanent Magnet DC Brushless DC Index

# Accessories

## For Induction AC Motors and Gearmotors

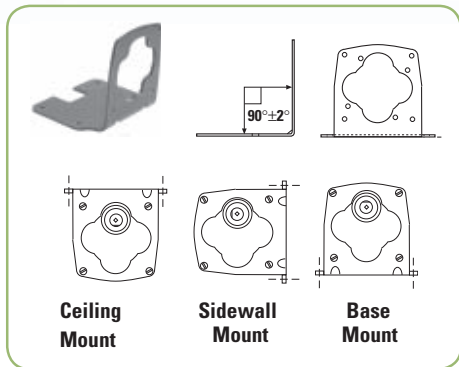

### Motor and Gearmotor "L" Brackets

Model No.	Description	lbs.	Dimensions	Deflection lbs.
0969	Kit for "E" and "F" gearmotors	2.5	Page 55	200
0970	Kit for "W" gearmotors	1.75	Page 54	125
0979	Kit for 34R motors	1	Page 48	25
0980	Kit for 34R-Z gearmotors	1.5	Page 53	100
5968	Kit for 30R motors, 30R-D gearmotors	1.25	Page 47, 52	50

Parallel shaft stock gearmotors are designed for universal horizontal mounting only. See "Mounting Positions" on page 2.

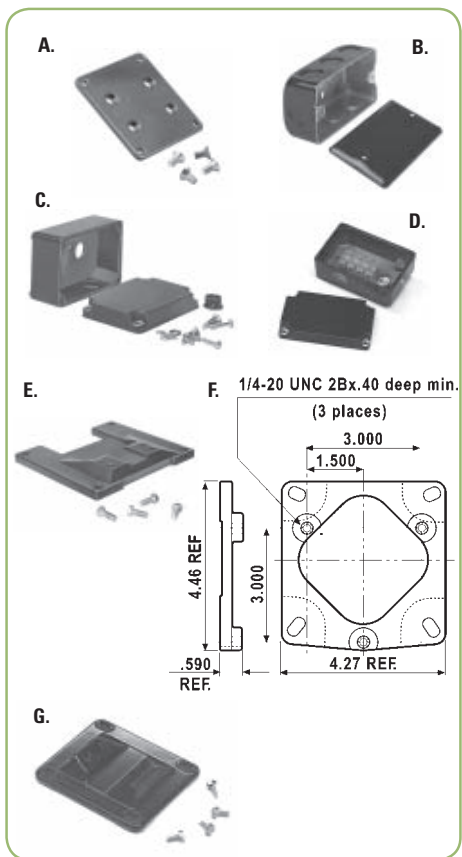

### Other Motor and Gearmotor Kits

Item	Model No.	Description	lbs.	Dimensions
A	0967	Base plate kit for 3F gearmotors	.5	Page 57
B	0982	Steel terminal box kit for 42R and 48R motors and gearmotors	2	—
C	0984	Die cast terminal box kit for 34R, 42R, and 48R motors and gearmotors	1	Page 45, 49, 50
—	5982	Die cast terminal box for 30R motors and gearmotors	1	—
—	1982	Die cast terminal box with terminal block for 30R motors and gearmotors	1	—
D	1984	Die cast terminal box kit with terminal block for 34R, 42R, and 48R motors and gearmotors	1	Page 45, 49, 50
E	0989	Die cast rigid base for 48R-F gearmotors	2.5	Page 56
F	0995	Adaptor plate kit, 3-point mounting for E and W gearmotors. Provides drop-in replacement for competitive gearmotors.	.5	—
G	0994	Base kit for 34R motor	.5	—



# Run Capacitors

## For AC Induction Motors and Gearmotors

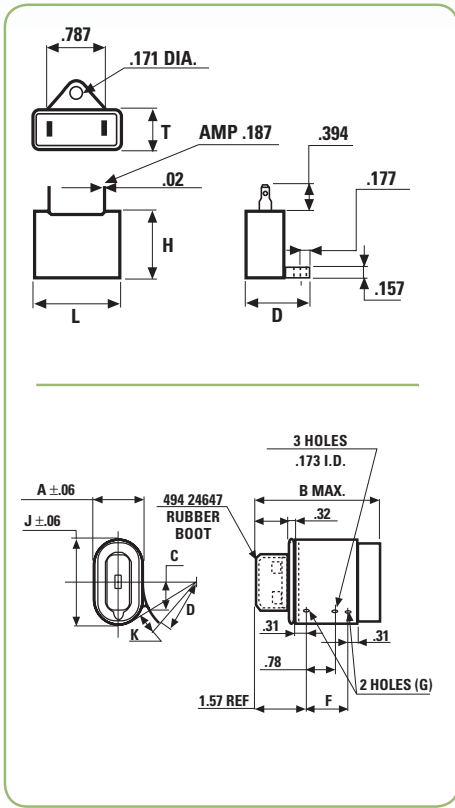

### Metalized Mylar Capacitor Dimensions

Part No.	Mfd. and Volts AC	L	H	T	D
494 00045	0.85-250	1.28	0.87	0.51	0.98
494 00046	1.00-250	1.28	0.87	0.51	0.98
494 00047	1.20-250	1.28	0.87	0.51	0.98
494 00048	1.30-250	1.28	0.87	0.51	0.98
494 00050	1.50-250	1.28	0.87	0.51	0.98
494 00051	1.60-250	1.28	0.87	0.51	0.98
494 01047	2.30-250	1.28	0.87	0.51	0.98
494 01049	0.40-440	1.31	1.03	0.58	1.04
494 01046	1.3-440	1.51	1.07	0.64	1.11
494 26812*	4.0-250	1.48	1.04	0.61	1.11
494 01015*	5.0-250	1.48	1.04	0.61	1.11
494 01054*	10.00-250	1.54	1.30	0.87	1.37
494 01006*	12.50-250	1.97	1.20	0.81	1.28
494 01016*	15.00-250	2.05	1.40	0.89	1.39
494 01090*	30-250	2.05	1.62	1.22	1.22

\* Instead of AMP blade type terminals these part numbers have 20 GA (stranded) black PVC wire, 3.5 in. long. These capacitors can fit inside Bodine model no. 0984 terminal kit.

### Oil Filled Capacitor Dimensions (inches)

Part No.	Mfd. and Volts AC	A	B	C	D	F	G	J	K
494 00098	2.5-370	1.31	3.18	0.88	1.62	1.12	.173	2.16	0.34
494 00028	3.75-370	1.31	3.18	0.88	1.62	1.12	.173	2.16	0.34
494 00029	5.0-370	1.31	3.68	0.88	1.62	1.12	.173	2.16	0.34
494 00031	7.5-370	1.31	4.56	0.88	1.62	1.12	.173	2.16	0.34
494 00032	10.0-370	1.91	3.51	1.08	2.50	1.50	.196	2.91	0.31
494 00033	12.5-370	1.91	3.51	1.08	2.50	1.50	.196	2.91	0.31
494 00034	15.0-370	1.91	3.51	1.08	2.50	1.50	.196	2.91	0.31
494 00035	20.0-370	1.91	4.01	1.08	2.50	1.50	.196	2.91	0.31
494 28281	25.0-370	1.91	3.875	1.08	2.50	1.50	.196	2.91	0.31

### Capacitor Cross Reference

Obsolete Part Number	New (Replacement) Part Number
494 00027	494 00098
494 00054	494 01047
494 00059	494 01049
494 00081	494 01054
494 00082	494 01006
494 00091	494 01046
494 00097	494 01016
494 29449	494 01015

# AC Technical Information

## Connection Diagrams

074 10292

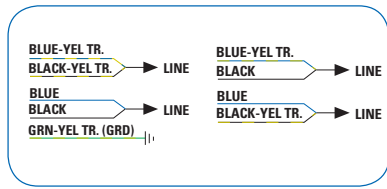

Connect as shown above for clockwise rotation while viewing the output shaft. To reverse direction transpose the black and black-yel. tr. leads.

074 10293

074 10296

074 10297

074 10004

074 10007 or 074 10102

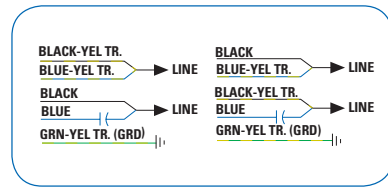

Connect as shown above for clockwise rotation while viewing the output shaft. To reverse direction transpose the black and black-yel. tr. leads.

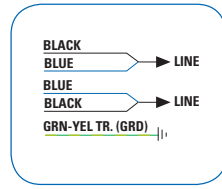

To reverse direction transpose any two leads.

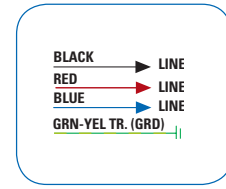

To reverse direction transpose any two leads.

074 10019

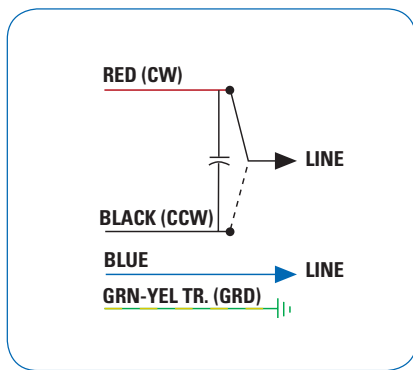

To reverse direction transpose red and black leads.

074 10021

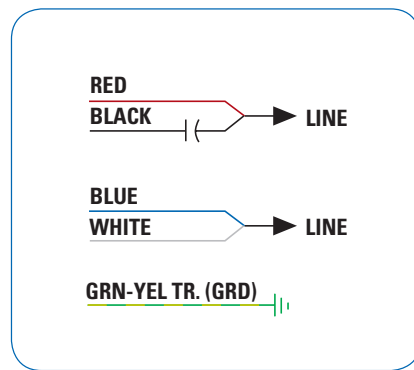

To reverse direction transpose red and blue leads.

074 10012 or 074 10103  
(9 leadS, 230/460 V)

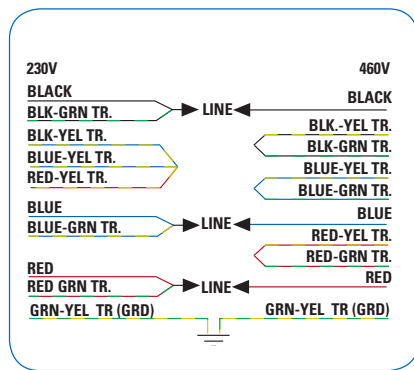

To reverse direction transpose any two leads or combinations.

074 10298 (9 leadS, 115/230 V)

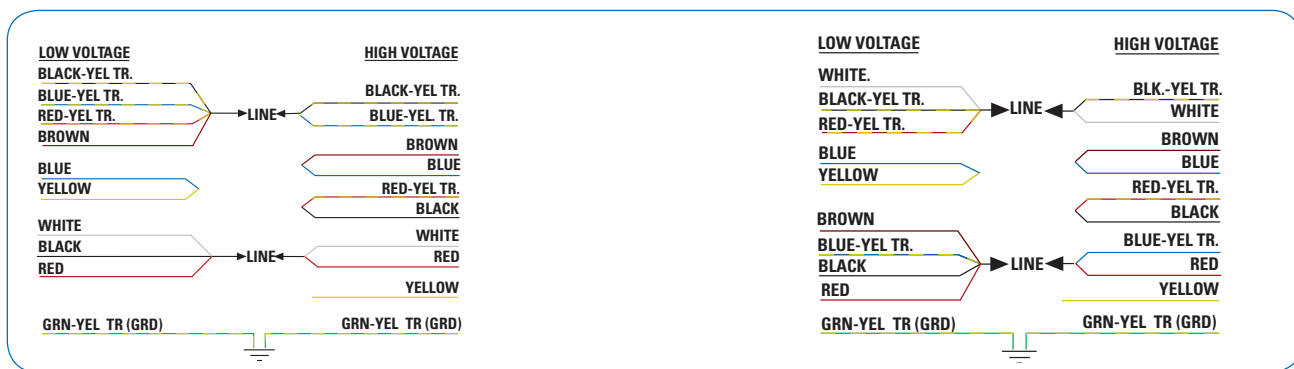

Connect as shown above for clockwise rotation while viewing the output shaft. To reverse direction with 115 V connection, transpose blue-yel. tr. and brown leads with white. To reverse direction with 230 V connection, transpose blue-yel. tr. with white lead.

074 10299 (9 leadS, 115/230 V)

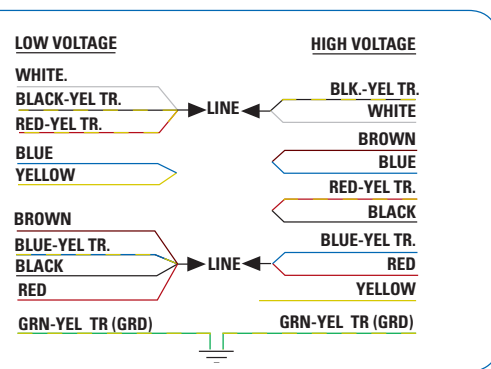

074 10294

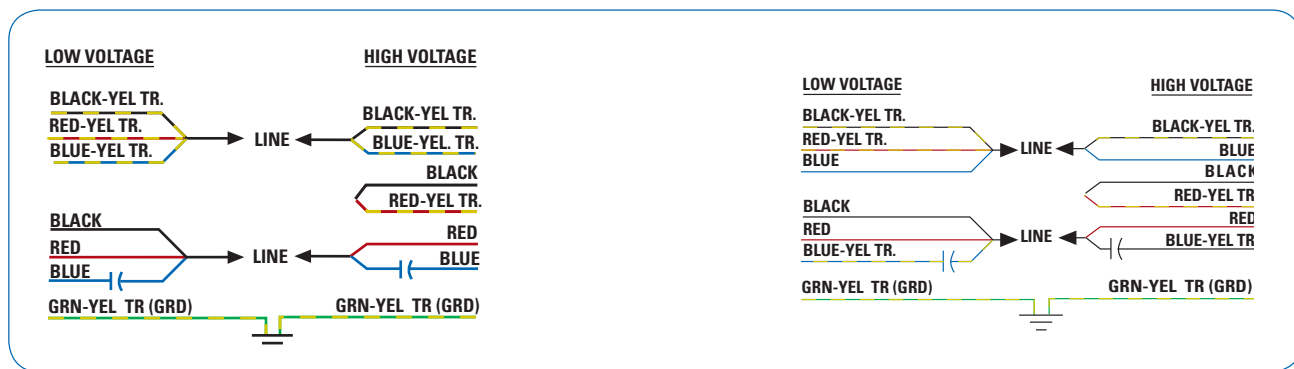

To reverse direction transpose blue and blue-yel. tr. leads.

074 10295

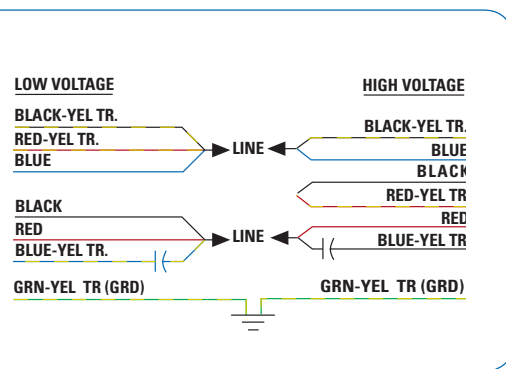

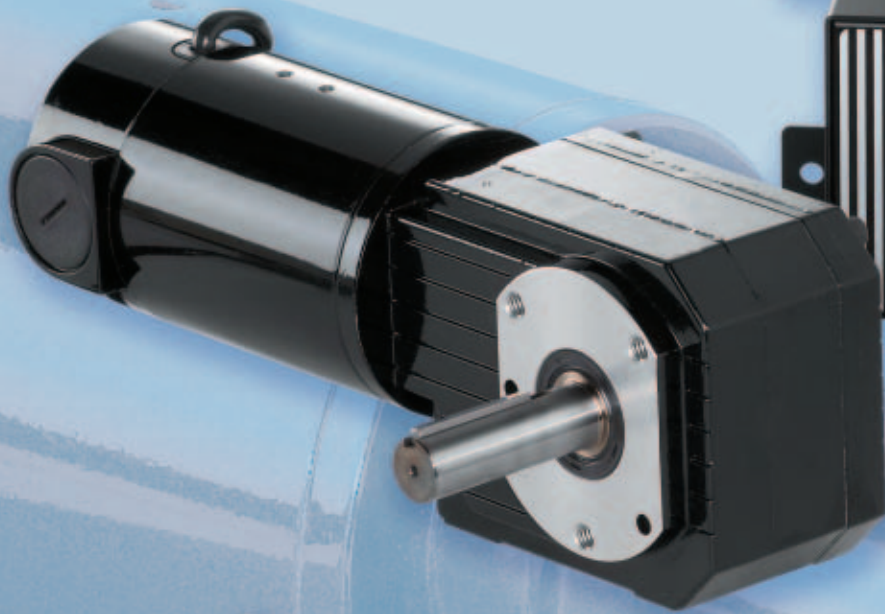

- The lowest-cost system for basic variable speed applications
- The most popular motor type for low voltage applications
- The highest starting torque per motor size for intermittent applications

# DC Products

# DC Technical Information

## PM Advantages

Permanent magnet DC (PMDC) motors and gearmotors are compact, mathematically predictable, can produce high starting torque and can be decelerated rapidly.

## CE certification

Bodine PMDC motors and gearmotors have CE marks. See page 2 for more information.

## Speed Regulation

In a PMDC motor, speed is proportional to voltage and torque is proportional to current. When voltage is held constant, the amount that speed drops due to increasing torque is called "speed regulation". The thin lines in Figure 1 illustrate motor performance without the aid of a regulating electronic control. The heavy lines illustrate performance from a control with "excellent" (1-3%) speed regulation.

Figure 1: Speed Regulation

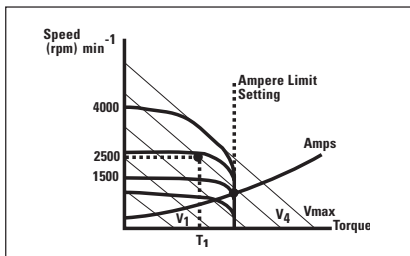

Regulated speed curves for a typical DC motor and speed control.

Speed controls such as those presented on page 86 provide several functions: (a) converting input AC voltage to DC for the motor, (b) a potentiometer enables the user to select the motor operating speed, (c) "automatic" circuitry regulates the motor speed, (d) other functions, such as braking/reversing, temperature and line voltage compensation, can be provided at additional cost.

The design of the electronic speed control has a dramatic effect on motor speed performance and life. SCR speed controls can be: (a) 1/2 wave or full-wave; (b) filtered or unfiltered. Most industrial controls are full-wave. We will assume full-wave rectification and discuss differences between filtered and unfiltered.

## Form Factor (FF)

Form Factor for a DC voltage electronic control is a measure of the amount of current (ampere) filtering (smoothing) provided by the control to a motor. Form Factor cannot be determined until a motor and control combination are driving a load. However, most control manufacturers catalog their controls with a FF rating. Most small motor and control combinations exhibit FF=1.0 to 1.05 with a filtered control and FF=1.6-1.8 with an unfiltered control at rated torque.

Most Bodine permanent magnet DC motors in this catalog are rated for continuous duty on 130 VDC, FF=1.05 current as supplied by Bodine type FPM and WPM controls. These motors and gearmotors can be successfully operated from unfiltered controls at FF=approximately 1.6, at speed not less than 1700 rpm. For intermittent duty operation, full nameplate torque may be available. The designers should test for each individual application.

## Peak torque

Peak torque indicates the maximum torques above rated that are acceptable when gearmotors are used with Bodine Controls. Peak torque is based on the load causing the motor portion to briefly exceed its rated horsepower and are limited by either 200% of rated torque or the approximate short term capacity of the gearhead. The user is cautioned that output torques higher than rated will reduce the life of the gearhead below its "design life." Also, winding life will be reduced when rated load (rated temperature rise) is exceeded.

## Motor Insulation Ratings

All Bodine PMDC motors are built with Class "F" insulation material (155°C total) for greater torque capability. However, the performance ratings of some models in this catalog are based on Class "B" (130°C total) for extended life.

## Speed Controls

Speed Controls for Bodine PMDC motors and gearmotors are featured beginning on page 86.

## DC Connection Diagram 074 10101

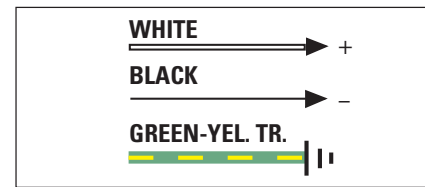

Connect as shown for clockwise rotation while viewing output shaft. To reverse direction, transpose white and black leads.

## Performance Curves

The performance curves below show motor performance on pure DC (FF=1.0).

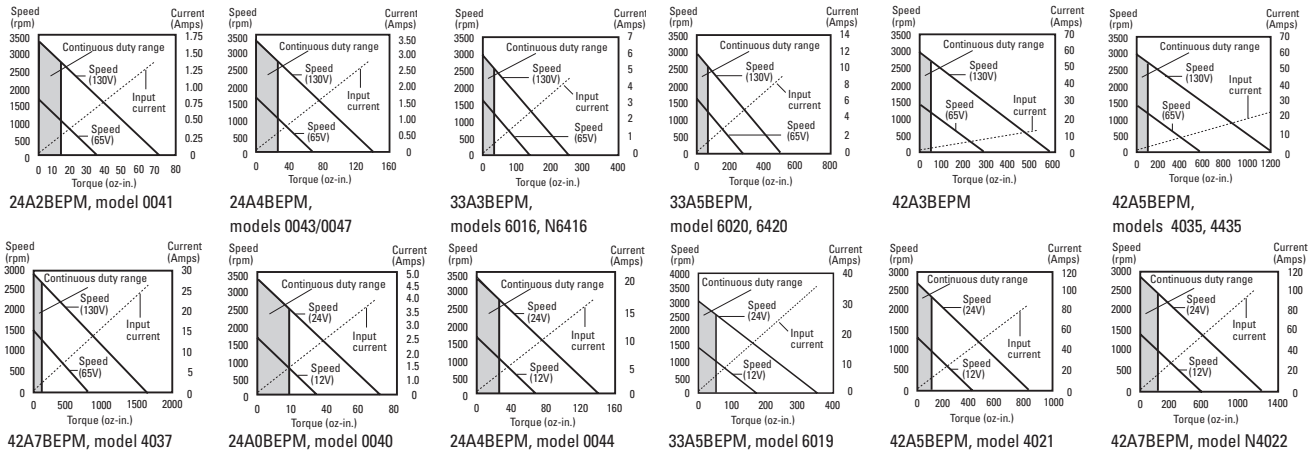

# Permanent Magnet DC Motors

1/50 - 1/7 HP



## Standard Features

- Totally Enclosed, Non-Ventilated (IP-40)
- Class "F" insulation, Class "B" rating
- External brush access for easy inspection and replacement
- Oversized brushes for long life
- Skewed armature for smooth low speed operation
- Oversized magnets resist demagnetization, stabilized to common strength for consistent performance
- High starting torque and self-braking
- Noise-tested ball bearings permanently lubricated
- Locked bearing minimizes endplay

## Application Information

- For connection diagram 074 10101 see page 66
- Performance ratings of 130 V models based on use with filtered controls
- Flange mount or base mount

## Optional Accessories

- Encoder model 0940, see page 101
- "L" bracket mount kit model 0990 available, see page 100

## Matching Controls

- Bodine stocks a full line of speed controls for Bodine PMDC motors. See pages 86-99

**90** COMPATIBLE WITH 90 V CONTROLS  
SEE PAGES 98 & 99

New  
e-TOR  
INTEGRAMOTOR™

Speed (rpm)	Rated Torque (oz-in.)	Rated Amp	HP	K <sub>T</sub> (oz-in/A)	K <sub>E</sub> (V/krpm)	Winding Resistance (ohms)	Winding Inductance (mH)	Rotor Inertia (oz-in-sec. <sup>2</sup> )	Radial Load (lbs.)	Length XH (inch)	Wt. (lbs.) Shaft	Product Type Shaft	Model Number <sup>1</sup>				
													24 V. Winding		130 V. Winding		
													Acc'y. Shaft	No Acc'y. Shaft	Base		Flange
2500	8	1.2	1/50	8.3	6.1	5.7	6.7	.003	25	3.31	2.0	24A0BEPM	N4440	N0040	-	-	-
2500	8	.22	1/50	42	31	176	220	.003	25	3.31	2.0	24A0BEPM	-	-	-	N4439	N0039
2500	16	1.8	1/29	10	7.5	2.5	3.6	.005	25	3.93	2.5	24A2BEPM	N4445	<b>0045</b>	-	-	-
2500	14	.30	1/29	55	41	84	133	.005	25	3.93	2.5	24A2BEPM	-	-	<b>0042</b>	N4441	<b>0041</b>
2500	22	2.6	1/18	9.2	6.8	2	6.7	.007	25	4.68	3.0	24A4BEPM	N4444	<b>0044</b>	-	-	-
2500	24	.45	1/17	55	40	5	184	.007	25	4.68	3.0	24A4BEPM	-	-	-	<b>0047</b>	<b>0043</b>
11,500	12	1.1	1/7	14	10	3.15	4.5	.007	25	4.68	3.0	24A4BEPM	-	-	<b>0049<sup>2</sup></b>	-	-

<sup>1</sup>NOTE: Model numbers shown in bold type are in stock. "N" model numbers require lead time and minimum quantities.

<sup>2</sup>NOTE: Ratings for model 0049 are based on 115 V, not 130 V.

## 24A Motor

**Flange Mount 24A Motor** shown with optional "L" bracket (model 0990)

"S" (4) slots .186 in. wide on a 2.7 to 2.83 bolt circle  
"F" See page 101 for "accessory ready" mounting dimensions.

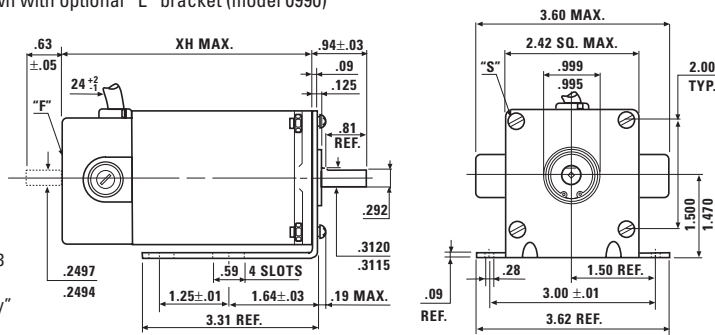

**Base Mount 24A Motor** shown with standard base (for motor model 0042 and 0049 only)

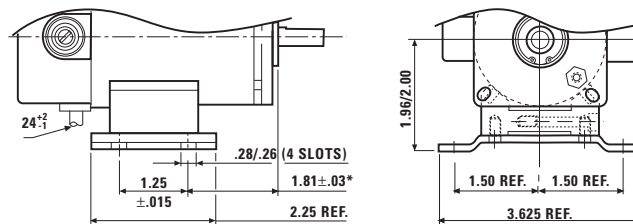

\* 1.62 ±.03 for model 0042



MADE IN U.S.A.

Hollow Shaft  
Custom  
Pacesetter™ Inverter Duty  
AC Induction  
Permanent Magnet DC  
Brushless DC  
Index

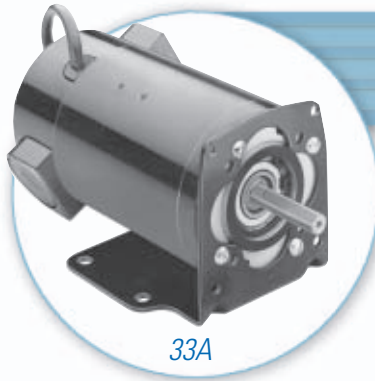

33A  
Shown with optional  
L-bracket

**90** COMPATIBLE WITH  
90 V CONTROLS  
SEE PAGES 98 & 99

## Permanent Magnet DC Motors

1/12 - 1/3 HP

### Standard Features

- Totally Enclosed, Non-Ventilated (IP-40)
- Class "F" insulation
- External brush access for easy inspection and replacement
- Constant force brush springs for long life and quietness
- Skewed armature for smooth low speed operation
- Oversized magnets resist demagnetization, stabilized to common strength for consistent performance
- High starting torque and self-braking
- Noise-tested ball bearings permanently lubricated
- Locked bearing minimizes endplay

### Application Information

- For connection diagram 074 10101 see page 66
- Performance ratings of 130 V models based on use with filtered controls
- Face mount is standard

### Optional Accessories

- Encoder model 0941, see page 101
- Brake model 0997, see page 100
- IP-44 achieved with terminal box model 0984 or 1984, see page 100
- "L" bracket mount kit model 5968 available, see page 100

### Matching Controls

- Bodine stocks a full line of speed controls for Bodine PMDC motors. See pages 86-99

Speed	Torque	Current	HP	FF	K <sub>T</sub> (oz-in/A)	K <sub>E</sub> (V/krpm)	Winding Resist.	Winding Induct.	Arm. Inertia	Radial Load	XH (in.)	Wt. (lbs.)	Product Type	Model Number <sup>1</sup>	
														Acc'y. Shaft	No Shaft
<b>24V, Class F Temperature Rating</b>															
2500	50	5.5	1/8	1.0	10.2	7.5	.66	1.9	.031	55	5.22	5.1	33A3BEPM	N6424	<b>6024</b>
2500	95	9.2	1/4	1.0	11.1	8.2	.29	0.98	.043	55	6.28	6.9	33A5BEPM	-	<b>6021</b>
2500	134	12	1/3	1.0	11.5	8.5	.31	0.59	.075	-	7.45	8.25	33A7BEPM	N6422	<b>6022</b>
<b>90 / 130V, Class F Temperature Rating</b>															
1725 / 2500	36/50	.78 / 1.0	1/16 / 1/8	1.4 / 1.0	56	42	22	.57	.031	55	5.22	5.1	33A3BEPM	<b>6434</b>	<b>6034</b>
1725 / 2500	73/95	1.4 / 1.8	1/8 / 1/4	1.4 / 1.0	60	44	11	.28	.043	55	6.28	6.9	33A5BEPM	<b>6435</b>	<b>6035</b>
1725 / 2500	97/134	1.8 / 2.4	1/6 / 1/3	1.4 / 1.0	66	49	8.8	.18	.075	55	7.45	8.25	33A7BEPM	-	<b>6037</b>

<sup>1</sup>NOTE: Model numbers shown in bold type are in stock. "N" model numbers require lead time and minimum quantities.

33A Motor shown with optional "L" bracket (model 5968)

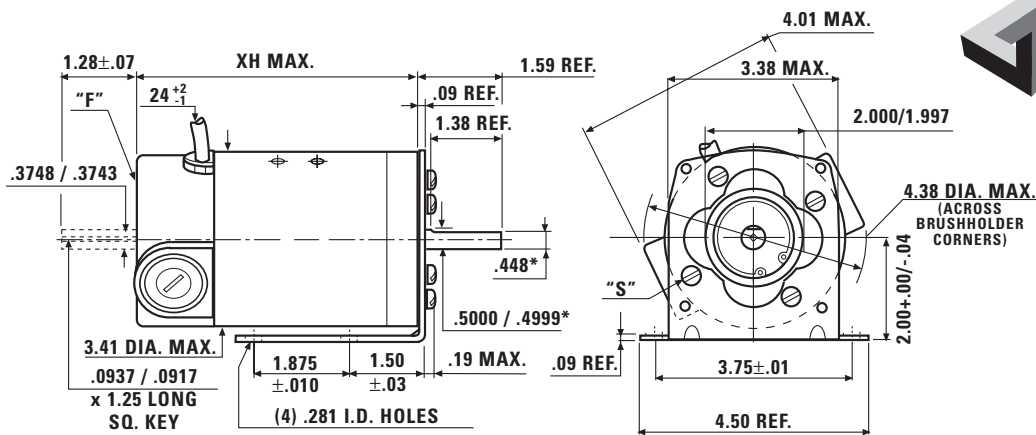

"S" (4) 10-32, UNF-2B, .25 in. deep minimum on 2.750±.015 in. bolt circle

"F" See page 101 for "accessory ready" mounting dimensions.

\* Shaft diameter is .3750/.3745 in. for models 6024 and N6424 with .347 in. dimension on flat.



# Permanent Magnet DC Motors

1/4 - 1/2 HP

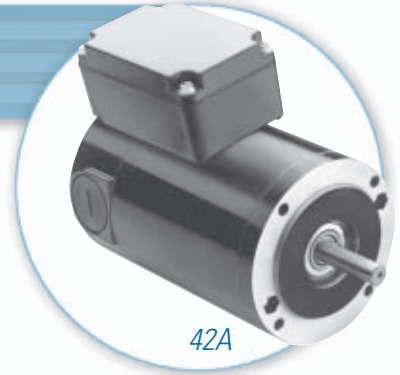

42A  
Shown with optional terminal box

**90** COMPATIBLE WITH 90 V CONTROLS  
SEE PAGES 98 & 99

## Standard Features

- Totally Enclosed Non-Ventilated (IP-40)
- Class "F" insulation
- External brush access for easy inspection and replacement
- Constant force brush springs for long life and quietness
- Skewed armature for smooth low speed operation
- Oversized magnets resist demagnetization, stabilized to common strength for consistent performance
- High starting torque and self-braking
- Noise-tested ball bearings permanently lubricated
- Locked bearing minimizes endplay

## Application Information

- For connection diagram 074 10101, see page 66
- Performance ratings of 130 V models based on use with filtered controls
- Face mount is standard

## Optional accessories

- Encoder model 0941, see page 101
- Brake model 0997, see page 100
- IP-44 achieved with terminal box model 0984 or 1984, see page 100
- IP-44 achieved with boot kit model 0978, see page 100
- Base mount kit model 0991, see page 100

## Matching Controls

- Bodine stocks a full line of speed controls for Bodine PMDC motors. See pages 86-99

Speed (rpm)	Rated Torque (oz.-in.)	Rated Amp	HP	K <sub>T</sub> (oz.-in/A)	K <sub>E</sub> (V/krpm)	Winding Resistance (ohms)	Winding Inductance (mH)	Rotor Inertia (oz.-in.-sec. <sup>2</sup> )	Radial Load (lbs.)	Length XH (inch)	Wt. (lbs.)	Product Type	Model Number <sup>1</sup>			
													24 Volt Winding		130 Volt Winding	
													Acc'y. Shaft	No Acc'y. Shaft	Acc'y. Shaft	No Acc'y. Shaft
<b>NEMA 42C Face Mount, Class B Temperature Rating</b>																
2500	101	8.8	1/4	12	9.2	.27	.64	.082	90	6.72	11.3	42A5BEPM	N4421	N4021	-	-
2500	101	1.8	1/4	60	44	5.5	20	.082	90	6.72	11.3	42A5BEPM	-	-	<b>4435</b>	<b>4035</b>
2500	135	12	1/3	12	9	.16	.45	.120	90	7.87	14.5	42A7BEPM	N4422	N4022	-	-
2500	135	2.3	1/3	64	47	4.2	17	.120	90	7.87	14.5	42A7BEPM	-	-	N4437	<b>4037</b>
<b>NEMA 42CZ Face Mount, Class F Temperature Rating</b>																
2500	150	15	1/3	11	8	.18	.61	.082	90	6.72	11.3	42A5BEPM	N4800	N4601	-	-
2500	150	2.7	1/3	60	45	3.2	-	.082	90	6.72	11.3	42A5BEPM	-	-	N4430	N4031
2500	180	19	1/2	11.5	8.5	.12	.54	.12	90	7.87	14.5	42A7BEPM	N4802	N4603	-	-
2500	180	3.4	1/2	57	42	2.7	-	.12	90	7.87	14.5	42A7BEPM	-	-	N4432	<b>4033</b>

<sup>1</sup> NOTE: Model numbers shown in bold type are in stock. "N" model numbers require lead time and minimum quantities.

## 42A Motor

NEMA 42C Face shown with optional base kit (model 0991)

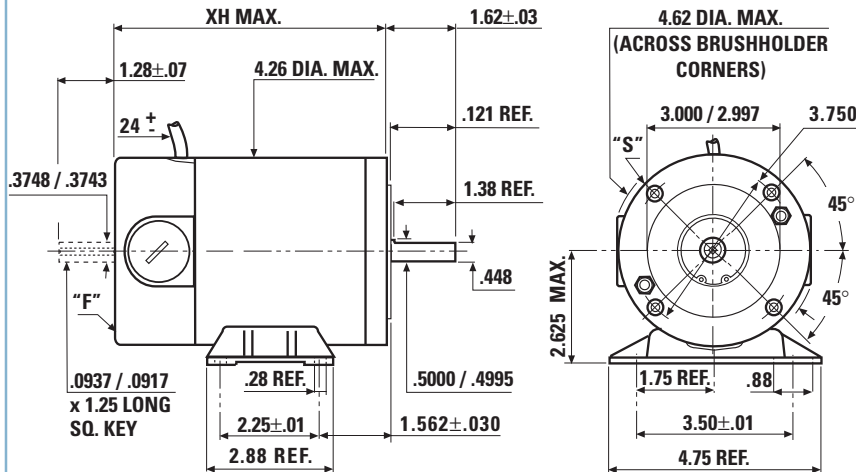

"S" (4) 1/4-20 UNC-2B: .30/.40 in. deep minimum  
"F" See page 101 for "accessory ready" mounting dimensions.



NEMA 42CZ Face

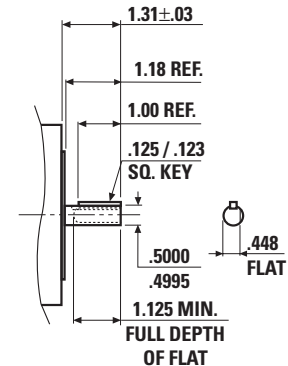

New  
e-TORQ™  
INTEGRATOR™  
Hollow Shaft  
Custom  
Pacesetter™ Inverter Duty  
AC Induction  
Permanent Magnet DC  
Brushless DC  
Index

# Parallel Shaft DC Gearmotors

Up to 40 lb-in. continuous

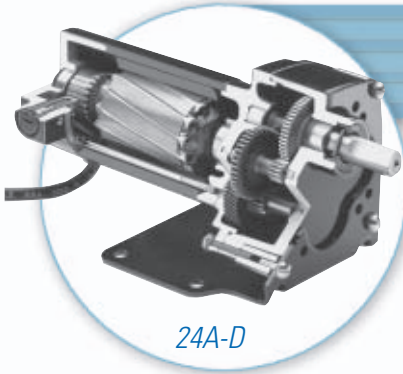

24A-D

Cutaway view

**90 COMPATIBLE WITH 90 V CONTROLS**  
SEE PAGES 98 & 99

### Standard Features

- 24A motor provides high starting torque, adjustable speed, and predictable performance under a range of operating conditions. (see page 67 for more details)
- Industrial lip type seals on motor and output shafts
- Needle bearing on output shaft for increased radial load capacity and long life
- Permanently lubricated with high-performance lubricant
- Reinforced thermoplastic helical gear on input stage for quietness and hardened steel spur gears on subsequent stages for high output torque and long life
- Helical pinion accurately cut on motor shaft for maximum strength and minimum noise

### Application Information

- For connection diagram 074 10101 see page 66
- Performance ratings of 130 V models based on use with filtered controls
- Face mount is standard

### Optional Accessories

- Encoder model 0940, see page 101
- "L" bracket mount kit model 5968, see page 100

### Matching Controls

- Bodine stocks a full line of speed controls for Bodine PMDC motors. See pages 86-99

Speed (rpm)	Rated Torque (lb-in.)	Current @ Rated Torque (Amps)		Peak Torque (lb-in.)	Motor HP	Gear Ratio	Radial Load (lbs.)	Length XH (inch)	Weight (lbs.)	Product Type	Model Number <sup>1</sup>			
		24 Volt Winding	130 Volt Winding								24 Volt Winding		130 Volt Winding	
											Accessory Shaft	No Accessory Shaft	Accessory Shaft	No Accessory Shaft
5.6	40	1.8	.3	55	1/29	450	65	5.97	4	24A2BEPM-D5	N4999	N4799	N4499	<b>0199</b>
8.3	40	1.8	.3	55	1/29	300	65	5.97	4	24A2BEPM-D5	N4998	N4798	N4498	<b>0198</b>
14	40	1.8	.3	55	1/29	180	65	5.97	4	24A2BEPM-D4	N4997	N4797	N4497	<b>0197</b>
28	40	1.8	.3	55	1/29	90	65	5.97	4	24A2BEPM-D4	N4996	N4796	N4496	<b>0196</b>
42	40	2.6	.48	55	1/17	60	65	6.72	4.5	24A4BEPM-D3	-	<b>4690</b>	-	<b>0190</b>
42	36	1.8	.3	55	1/29	60	65	5.97	4	24A2BEPM-D3	N4995	N4795	N4495	<b>0195</b>
83	29	2.6	.48	33	1/17	30	65	6.72	4.5	24A4BEPM-D3	-	-	-	<b>0189</b>
83	18	1.8	.3	33	1/29	30	65	5.97	4	24A2BEPM-D3	N4994	N4794	N4494	<b>0194</b>
139	17	2.6	.48	20	1/17	18	65	6.72	4.5	24A4BEPM-D3	-	-	-	<b>0188</b>
139	11	1.8	.3	20	1/29	18	65	5.97	4	24A2BEPM-D3	N4993	N4793	N4493	<b>0193</b>
208	12	2.6	.48	13	1/17	12	65	6.72	4.5	24A4BEPM-D3	-	-	-	<b>0187</b>
208	7.1	1.8	.3	13	1/29	12	65	5.97	4	24A2BEPM-D3	N4992	N4792	N4492	<b>0192</b>
417	5.4	2.6	.48	6.2	1/17	6	65	6.72	4.5	24A4BEPM-D3	-	-	-	<b>0186</b>
417	3.3	1.8	.3	6.2	1/29	6	65	5.97	4	24A2BEPM-D3	N4991	N4791	N4491	<b>0191</b>

<sup>1</sup>NOTE: Model numbers shown in bold type are in stock. "N" model numbers require lead time and minimum quantities.

24A-D Gearmotor shown with optional "L" bracket (model 5968)

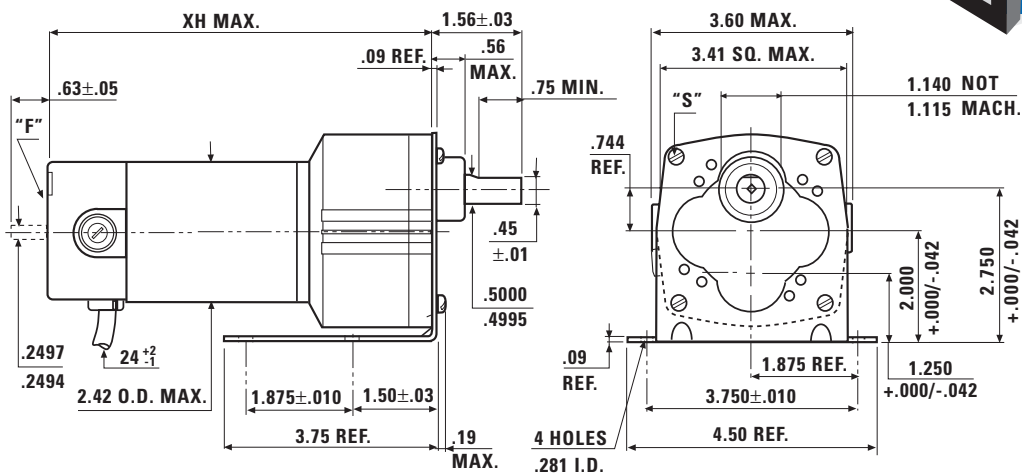

"S" (4) 10-32 UNF-2B, .38 in. deep minimum on a 3.75" bolt circle  
"F" See page 101 for "accessory ready" mounting dimensions.





# Parallel Shaft DC Gearmotors

Up to 100 lb-in. continuous

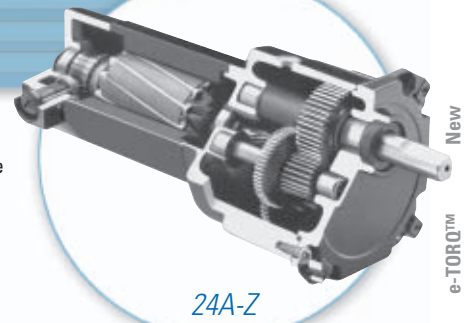

24A-Z

Cutaway view

**90 COMPATIBLE WITH 90 V CONTROLS**  
SEE PAGES 98 & 99

### Standard Features

- 24A motor provides high starting torque, adjustable speed, and predictable performance under a range of operating conditions. (see page 67 for more details)
- Industrial lip type seals on motor and output shafts
- Needle bearing on output shaft for increased radial load capacity and long life
- Permanently lubricated with high-performance lubricant
- Wide reinforced thermoplastic helical gear on input stage of most models for quietness and wide hardened steel spur gears on subsequent stages for high output torque and long life
- Helical pinion accurately cut on motor shaft for maximum strength and minimum noise

### Application Information

- For connection diagram 074 10101 see page 66
- Performance ratings of 130 V models based on use with filtered controls
- Face mount is standard

### Optional Accessories

- Encoder model 0940, see page 101
- "L" bracket mount kit model 5968, see page 100

### Matching Controls

- Bodine stocks a full line of speed controls for Bodine PMDC motors. See pages 86-99

Speed (rpm)	Rated Torque (lb-in.)	Current @ Rated Torque (Amps)		Peak Torque (lb-in.)	Motor HP	Gear Ratio	Radial Load (lbs.)	Length XH (inch)	Weight (lbs.)	Product Type	Model Number <sup>1</sup>			
		24 Volt Winding	130 Volt Winding								24 Volt Winding		130 Volt Winding	
											Accessory Shaft	No Accessory Shaft	Accessory Shaft	No Accessory Shaft
14	100	2.6	.48	115	1/17	180	125	7.82	5	24A4BEPM-Z4	N4963	<b>4663</b>	N4563	<b>0163</b>
28	92	2.6	.48	115	1/17	90	125	7.82	5	24A4BEPM-Z4	N4962	N4662	N4562	<b>0162</b>
42	65	2.6	.48	115	1/17	60	125	7.82	5	24A4BEPM-Z3	N4961	N4661	N4561	<b>0161</b>
83	33	2.6	.48	59	1/17	30	125	7.82	5	24A4BEPM-Z3	N4960	<b>4660</b>	N4560	<b>0160</b>
139	21	2.6	.48	38	1/17	18	100	6.92	5	24A4BEPM-Z2	N4959	N4659	N4559	<b>0159</b>
208	14	2.6	.48	25	1/17	12	100	6.92	5	24A4BEPM-Z2	N4958	N4658	N4558	<b>0158</b>
417	7	2.6	.48	13	1/17	6	100	6.92	5	24A4BEPM-Z2	N4957	N4657	N4557	N0157
<b>Steel First-Stage Gear and Class F Ratings</b>														
139	34	—	.81	—	1/11	18	100	6.92	5	24A4BEPM-Z2	—	—	—	<b>7159</b>

<sup>1</sup>NOTE: Model numbers shown in bold type are in stock. "N" model numbers require lead time and minimum quantities.

24A-Z Gearmotor shown with optional "L" bracket (model 5968)

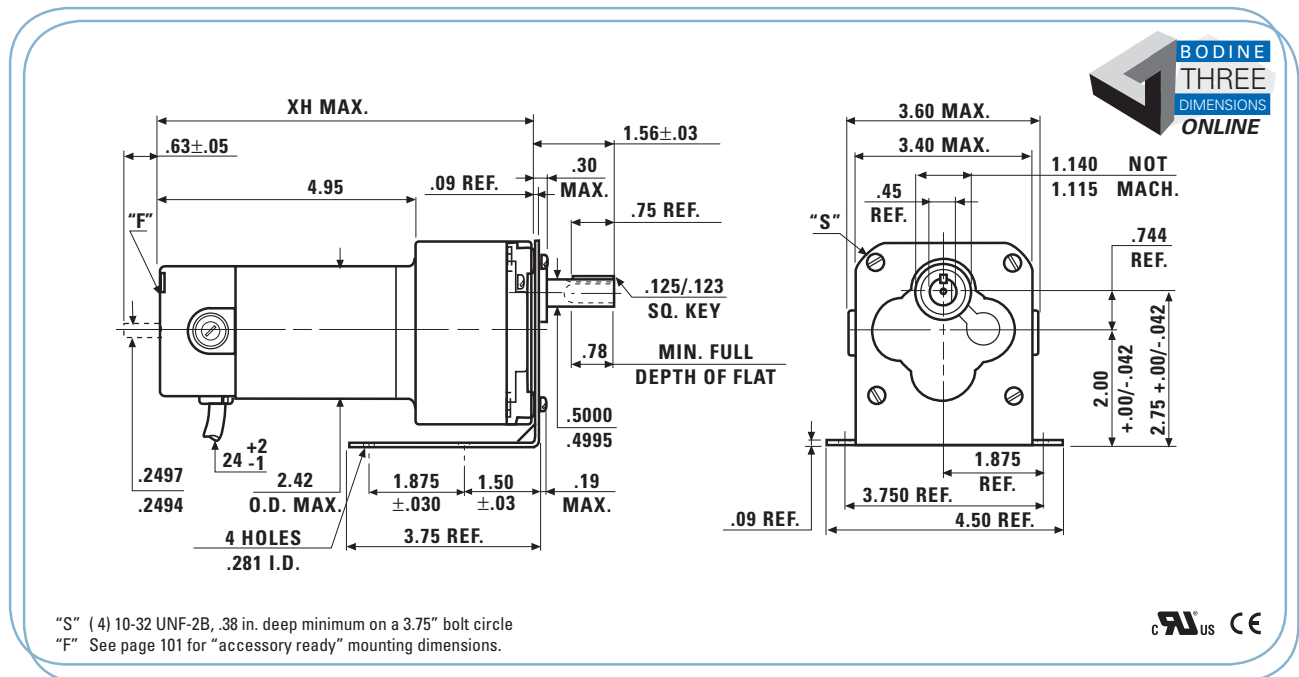

MADE IN U.S.A.

New  
e-TORQ™  
INTEGRAMOTOR™  
Hollow Shaft  
Custom  
Pacesetter™ Inverter Duty  
AC Induction  
Permanent Magnet DC  
Brushless DC  
Index

# Parallel Shaft DC Gearmotors

Up to 95 lb-in. continuous



33A-Z

### Standard Features

- 33A motor provides high starting torque, adjustable speed, and predictable performance under a range of operating conditions. (see page 68 for more details)
- Industrial lip type seals on motor and output shafts
- Needle bearing on output shaft for increased radial load capacity and long life
- Permanently lubricated with high-performance lubricant
- Wide reinforced thermoplastic helical gear on input stage for quietness and wide hardened steel spur gears on subsequent stages for high output torque and long life
- Helical pinion accurately cut on motor shaft for maximum strength and minimum noise

### Application Information

- For connection diagram 074 10101 see page 66
- Performance ratings of 130 V models based on use with filtered controls
- Face mount is standard

### Optional Accessories

- Encoder model 0941, see page 101
- Brake model 0997, see page 100
- IP-44 achieved with terminal box model 0984 or 1984, see page 100
- "L" bracket kit model 5968, see page 100

### Matching Controls

- Bodine stocks a full line of speed controls for Bodine PMDC motors. See pages 86-99

**90 COMPATIBLE WITH 90 V CONTROLS**  
SEE PAGES 98 & 99

Speed (rpm)	Rated Torque (lb-in.)	Current @ Rated Torque (Amps)		Peak Torque (lb-in.)	Motor HP	Gear Ratio	Radial Load (lbs.)	Length XH (inch)	Weight (lbs.)	Product Type	Model Number <sup>1</sup>			
		24 Volt Winding	130 Volt Winding								24 Volt Winding		130 Volt Winding	
											Accessory Shaft	No Accessory Shaft	Accessory Shaft	No Accessory Shaft
42	95	3.7	.74	115	1/12	60	125	7.90	5.8	33A3BEPM-Z3	N6969	N6669	N6569	<b>6169</b>
83	47	3.7	.74	59	1/12	30	125	7.90	5.8	33A3BEPM-Z3	N6968	N6668	N6568	<b>6168</b>
139	31	3.7	.74	38	1/12	18	100	7.00	5.8	33A3BEPM-Z2	N6967	N6667	N6567	<b>6167</b>
208	20	3.7	.74	25	1/12	12	100	7.00	5.8	33A3BEPM-Z2	N6966	N6666	N6566	<b>6166</b>
417	10	3.7	.74	13	1/12	6	100	7.00	5.8	33A3BEPM-Z2	N6965	N6665	N6565	<b>6165</b>

<sup>1</sup> NOTE: Model numbers shown in bold type are in stock. "N" model numbers require lead time and minimum quantities.



33A-Z Gearmotor shown with optional "L" bracket (model 5968)

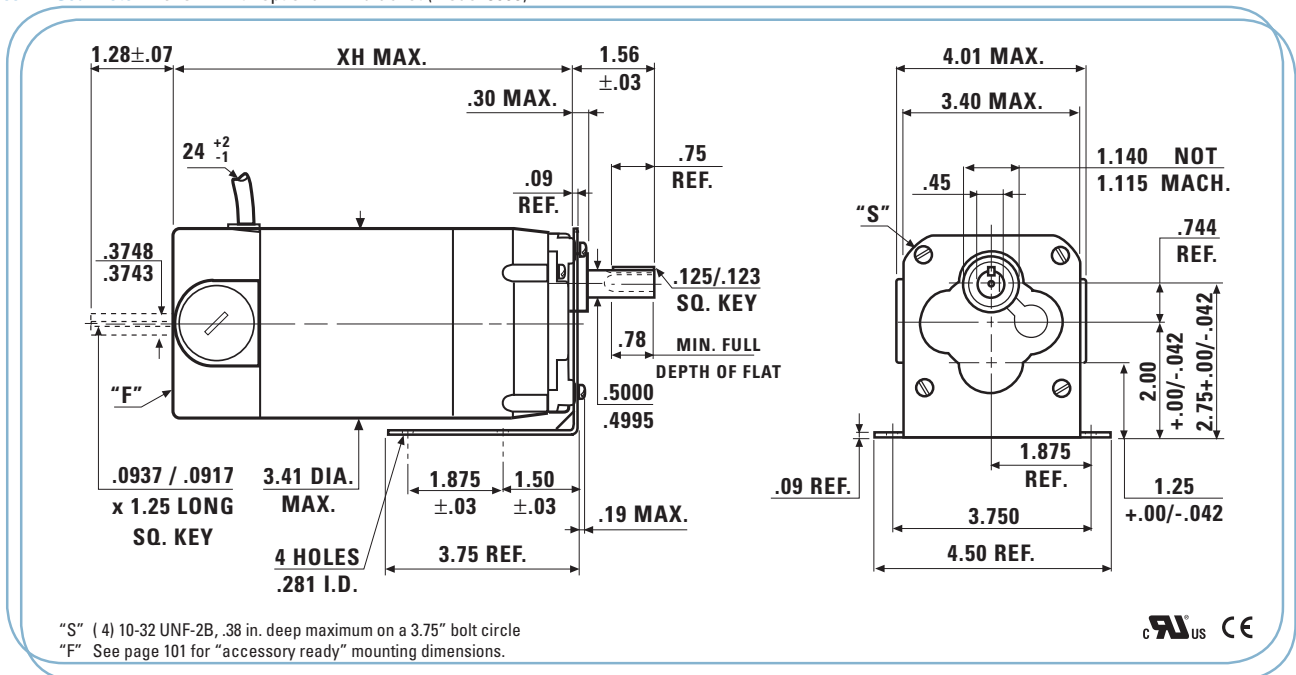

# Parallel Shaft DC Gearmotors

Up to 200 lb-in. continuous

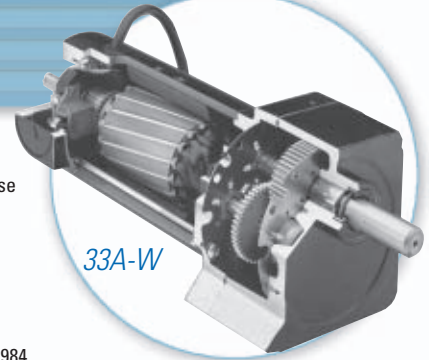

33A-W

Cutaway view

## Standard Features

- 33A motor provides high starting torque, adjustable speed, and predictable performance under a range of operating conditions. (see page 68 for more details)
- Industrial lip type seals on motor and output shafts
- Needle bearing on output shaft for increased radial load capacity and long life
- Permanently lubricated gearing utilizing semi-fluid grease for long life
- Wide reinforced thermoplastic helical gear on input stage of most models for quietness and hardened steel spur gears on subsequent stages for high output torque and long life
- Helical pinion accurately cut on motor shaft for maximum strength and minimum noise

## Application Information

- For connection diagram 074 10101 see page 66
- Performance ratings of 130 V models based on use with filtered controls
- Face mount is standard

## Optional Accessories

- Encoder model 0941, see page 101
- Brake model 0997, see page 100
- IP-44 achieved with terminal box model 0984 or 1984, see page 100
- "L" bracket kit model 0970, see page 100
- Adaptor plate kit model 0995 provides for drop-in replacement of competitive gearmotors

## Matching Controls

- Bodine stocks a full line of speed controls for Bodine PMDC motors. See pages 86-99



		Current @ Rated Torque (Amps)						Model Number <sup>1</sup>						
		24 Volt Winding		130 Volt Winding						24 Volt Winding		130 Volt Winding		
Speed (rpm)	Rated Torque (lb-in.)	24 Volt Winding	130 Volt Winding	Peak Torque (lb-in.)	Motor HP	Gear Ratio	Radial Load (lbs.)	Length XH (inch)	Weight (lbs.)	Product Type	Accessory Shaft	No Accessory Shaft	Accessory Shaft	No Accessory Shaft
8	175	3.7	.74	210	1/12	312.4	130	7.75	7.9	33A3BEPM-W4	N6947	<b>6647</b>	N6547	<b>6147</b>
15	166	3.7	.74	207	1/12	172.1	130	7.75	7.9	33A3BEPM-W4	N6946	N6646	N6546	<b>6146</b>
26	155	5.5	.91	190	1/8	97.5	130	8.81	9.7	33A5BEPM-W4	N6956	<b>6656</b>	N6556	<b>6156</b>
38	143	5.5	.91	157	1/8	65.5	130	8.81	9.7	33A5BEPM-W3	N6955	N6655	N6555	<b>6155</b>
57	96	5.5	.91	105	1/8	43.9	130	8.81	9.7	33A5BEPM-W3	N6954	<b>6654</b>	N6554	<b>6154</b>
84	65	5.5	.91	71	1/8	29.7	130	8.81	9.7	33A5BEPM-W3	N6953	N6653	N6553	<b>6153</b>
123	46	5.5	.91	52	1/8	20.4	65	8.81	9.7	33A5BEPM-W2	N6952	<b>6652</b>	N6552	<b>6152</b>
181	31	5.5	.91	35	1/8	13.8	65	8.81	9.7	33A5BEPM-W2	N6951	N6651	N6551	<b>6151</b>
266	21	5.5	.91	24	1/8	9.4	65	8.81	9.7	33A5BEPM-W2	N6950	N6650	N6550	<b>6150</b>
456	12	5.5	.91	14	1/8	5.5	65	8.81	9.7	33A5BEPM-W2	N6949	N6649	N6549	<b>6149</b>
660	6	5.5	.91	7	1/8	3.8	65	8.81	9.7	33A5BEPM-W2	N6948	N6648	N6548	<b>6148</b>
<b>Steel First-Stage Gear and Class F Ratings</b>														
219	39	—	1.84	—	1/4	11.4	65	8.81	9.7	33A5FEPM-W2	—	—	<b>6757</b>	—

<sup>1</sup>NOTE: Model numbers shown in bold type are in stock. "N" model numbers require lead time and minimum quantities.

33A-W Gearmotor shown with optional "L" bracket (model 0970)

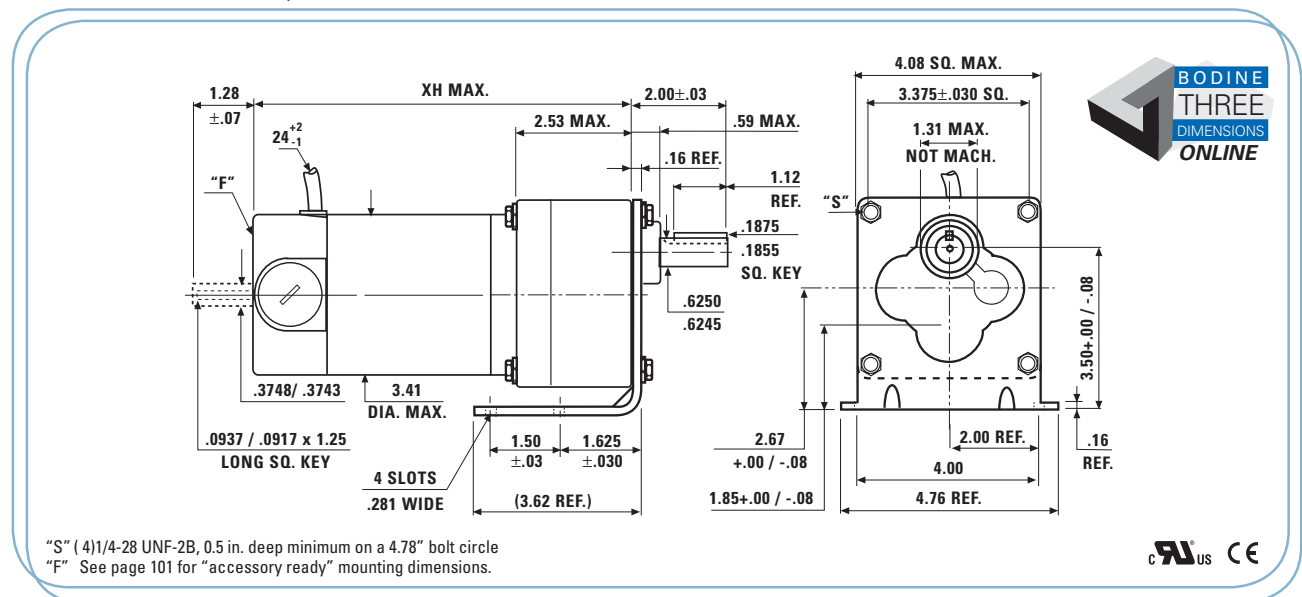

MADE IN U.S.A.

New  
e-TORQ™  
INTEGRATOR™  
Hollow Shaft  
Custom  
Pacesetter™ Inverter Duty  
AC Induction  
Permanent Magnet DC  
Brushless DC  
Index



# Parallel Shaft DC Gearmotors

Up to 341 lb-in. continuous

42A-E & 42A-F

**90** COMPATIBLE WITH  
90 V CONTROLS  
SEE PAGES 98 & 99

### Standard Features

- 42A motor provides high starting torque, adjustable speed, and predictable performance under a range of operating conditions. (see page 69 for more details)
- Industrial lip type seals on motor and output shafts
- Needle bearing on output shaft for increased radial load capacity and long life
- Permanently lubricated gearing utilizing semi-fluid grease for long life
- Selectively hardened steel helical gearing for quietness and high output to size ratio
- Helical pinion accurately cut on motor shaft for maximum strength and minimum noise

- Performance ratings of 130 V models based on use with filtered controls
- Face mount is standard

### Optional Accessories

- Encoder model 0941, see page 101
- Brake model 0997, see page 100
- IP-44 achieved with terminal box model 0984 or 1984, see page 100
- IP-44 achieved with boot kit model 0978, see page 100
- "L" bracket kit model 0969, see page 100
- Adaptor plate kit model 0995 provides for drop-in replacement of competitive gearmotors

### Application Information

- For connection diagram 074 10101 see page 66

### Matching Controls

- Bodine stocks a full line of speed controls for Bodine PMDC motors. See pages 86-99

Speed (rpm)	Rated Torque (lb-in.)	Current @ Rated Torque (Amps)		Peak Torque (lb-in.)	Motor HP	Gear Ratio	Radial Load (lbs.)	Length XH (inch)	Weight (lbs.)	Product Type	Model Number <sup>1</sup>			
		24 Volt Winding	130 Volt Winding								24 Volt Winding		130 Volt Winding	
											Accessory Shaft	No Accessory Shaft	Accessory Shaft	No Accessory Shaft
8.3	310	5.8	1.0	475	1/8	300	200	8.25	12.7	42A3BEPM-E4	N4975	N4675	N4575	<b>4175</b>
14	341	5.8	1.0	475	1/8	180	200	8.25	12.7	42A3BEPM-E4	N4974	N4674	N4574	<b>4174</b>
21	283	5.8	1.0	475	1/8	120	200	8.25	12.7	42A3BEPM-E4	N4973	N4673	N4573	<b>4173</b>
42	270	8.8	1.8	421	1/4	60	200	9.37	14.9	42A5BEPM-E3	N4985	<b>4685</b>	<b>4585</b>	<b>4185</b>
62	220	12	2.3	440	1/3	40	300	10.5	18.1	42A7BEPM-F3	N4984	N4684	N4584	<b>4193</b>
62	180	8.8	1.8	280	1/4	40	200	9.37	14.9	42A5BEPM-E3	N4976	N4676	N4576	<b>4184</b>
83	135	8.8	1.8	318	1/4	30	300	9.37	14.9	42A5BEPM-E3	N4983	N4683	<b>4583</b>	<b>4183</b>
125	145	—	2.3	—	1/3	20	300	10.5	18.1	42A7BEPM-F3	—	—	—	<b>4192</b>
125	90	8.8	1.8	212	1/4	20	300	9.37	14.9	42A5BEPM-E3	N4982	N4682	N4582	<b>4182</b>
165	109	—	2.3	—	1/3	15	300	10.5	18.1	42A7BEPM-F2	—	—	—	<b>4191</b>
165	68	8.8	1.8	160	1/4	15	300	9.37	14.9	42A5BEPM-E2	N4981	N4681	N4581	<b>4181</b>
250	72	12	2.3	144	1/3	10	300	10.5	18.1	42A7BEPM-F2	N4978	N4678	N4578	<b>4190</b>
250	45	8.8	1.8	106	1/4	10	300	9.37	14.9	42A5BEPM-E2	N4980	N4680	<b>4580</b>	<b>4180</b>
500	25	8.8	1.8	55	1/4	5	300	9.37	14.9	42A5BEPM-E1	N4979	N4679	N4579	<b>4179</b>

<sup>1</sup> NOTE: Model numbers shown in bold type are in stock. "N" model numbers require lead time and minimum quantities.

42A-E/42A-F Gearmotor shown with optional "L" bracket (model 0969)

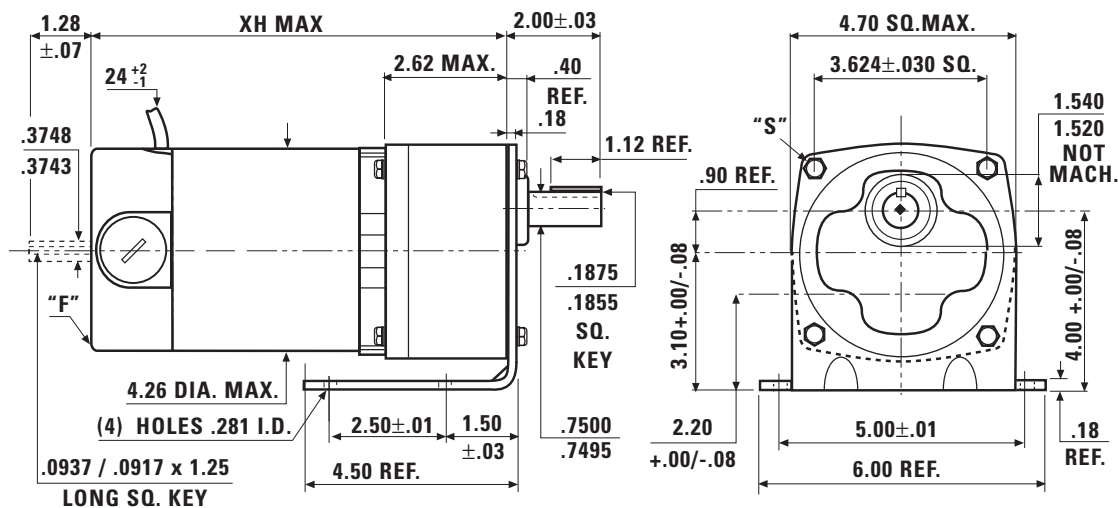

"S" (4) 1/4-28 UNF -2B, 0.5 in. deep minimum on a 5.13" bolt circle  
"F" See page 101 for "accessory ready" mounting dimensions.



# Parallel Shaft DC Gearmotors

Up to 341 lb-in. continuous



33A-E & 33A-F

### Standard Features

- 33A motor provides high starting torque, adjustable speed, and predictable performance under a range of operating conditions. (see page 68 for more details)
- Industrial lip type seals on motor and output shafts
- Needle bearing on output shaft for increased radial load capacity and long life
- Permanently lubricated gearing utilizing semi-fluid grease for long life
- Selectively hardened steel helical gearing for quietness and high output to size ratio
- Helical pinion accurately cut on motor shaft for maximum strength and minimum noise

### Application Information

- For connection diagram 074 10101 see page 66
- Face mount is standard

### Optional Accessories

- Encoder model 0941, see page 101
- Brake model 0997, see page 100
- IP-44 achieved with terminal box model 0984 or 1984, see page 100
- "L" bracket kit model 0969, see page 100
- Adaptor plate kit model 0995 provides for drop-in replacement of competitive gearmotors

### Matching Controls

- Bodine stocks a full line of speed controls for Bodine PMDC motors. See pages 86-99

Speed (rpm)	Rated Torque (lb-in.)	Rated Current (Amps)	Peak Torque (lb-in.)	HP	FF	Gear Ratio (lbs.)	Radial Load	Length (XH) (inch)	Wt. (lbs.)	Product Type	Model Number <sup>1</sup>	
											Acc'y. Shaft	No Acc'y. Shaft
<b>24V, Class F Temperature Rating</b>												
21	280	5.5	475	1/8	1.0	120:1	195	8.06	8.7	33A3BEPM-E4	N6973	N6673
42	270	9.2	421	1/4	1.0	60:1	240	9.12	10.5	33A5BEPM-E3	N6985	<b>6685</b>
62	220	12	440	1/3	1.0	40:1	250	10.32	11.9	33A7BEPM-F3	N6984	<b>6684</b>
250	72	12	144	1/3	1.0	10:1	300	10.32	11.9	33A7BEPM-F2	N6978	N6678
250	45	9.2	106	1/4	1.0	10:1	300	9.12	10.5	33A5BEPM-E2	N6980	<b>6680</b>
500	37	12	74	1/3	1.0	5:1	60	10.32	11.9	33A7BEPM-F1	N6991	N6691
500	24	9.2	55	1/4	1.0	5:1	60	9.12	10.5	33A5BEPM-E1	N6979	N6679
<b>90 / 130V, Class F Temperature Rating</b>												
5.8 / 8.3	310 / 310	.78 / 1.0	475	1/16 / 1/8	1.4 / 1.0	300:1	220	8.06	8.7	33A3BEPM-E4	-	<b>6175</b>
9.6 / 14	279 / 341	.78 / 1.0	475	1/16 / 1/8	1.4 / 1.0	180:1	200	8.06	8.7	33A3BEPM-E4	-	<b>6174</b>
14 / 21	198 / 280	.78 / 1.0	475	1/16 / 1/8	1.4 / 1.0	120:1	195	8.06	8.7	33A3BEPM-E4	N6573	<b>6173</b>
29 / 42	226 / 270	1.4 / 1.8	421	1/8 / 1/4	1.4 / 1.0	60:1	240	9.12	10.5	33A5BEPM-E3	<b>6585</b>	<b>6185</b>
43 / 62	205 / 220	1.8 / 2.4	440	1/6 / 1/3	1.4 / 1.0	40:1	250	10.32	11.9	33A7BEPM-F3	-	<b>6193</b>
43 / 62	151 / 180	1.4 / 1.8	280	1/8 / 1/4	1.4 / 1.0	40:1	250	9.12	10.5	33A5BEPM-E3	N6584	<b>6184</b>
58 / 83	113 / 135	1.4 / 1.8	318	1/8 / 1/4	1.4 / 1.0	30:1	300	9.12	10.5	33A5BEPM-E3	<b>6583</b>	<b>6183</b>
86 / 125	75 / 90	1.4 / 1.8	212	1/8 / 1/4	1.4 / 1.0	20:1	300	9.12	10.5	33A5BEPM-E3	-	<b>6182</b>
115 / 165	57 / 68	1.4 / 1.8	160	1/8 / 1/4	1.4 / 1.0	15:1	300	9.12	10.5	33A5BEPM-E2	-	<b>6181</b>
173 / 250	51 / 72	1.8 / 2.4	144	1/6 / 1/3	1.4 / 1.0	10:1	300	10.32	11.9	33A7BEPM-F2	N6578	<b>6190</b>
173 / 250	38 / 45	1.4 / 1.8	106	1/8 / 1/4	1.4 / 1.0	10:1	300	9.12	10.5	33A5BEPM-E2	<b>6580</b>	<b>6180</b>
345 / 500	26 / 37	1.8 / 2.4	74	1/6 / 1/3	1.4 / 1.0	5:1	60	10.32	11.9	33A7BEPM-F1	N6591	<b>6191</b>
345 / 500	19 / 24	1.4 / 1.8	55	1/8 / 1/4	1.4 / 1.0	5:1	60	9.12	10.5	33A5BEPM-E1	N6579	<b>6179</b>

<sup>1</sup> NOTE: Model numbers shown in bold type are in stock. "N" model numbers require lead time and minimum quantities.

### 33A-E/33A-F Gearmotor

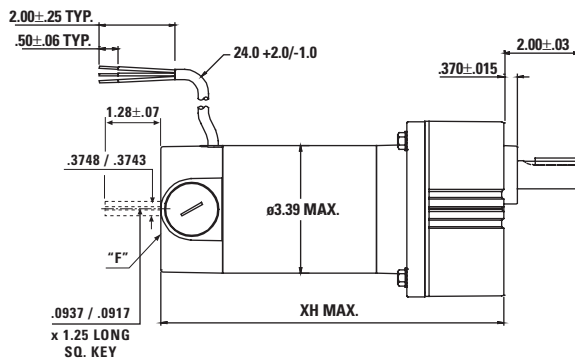

"F" See page 101 for "accessory ready" mounting dimensions.

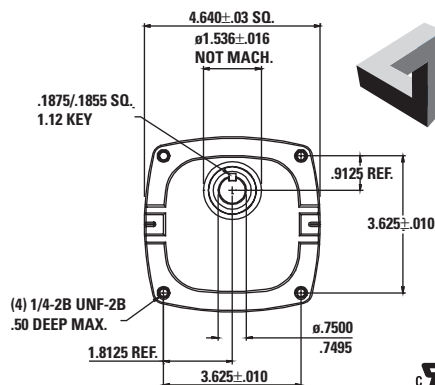

# Right Angle DC Gearmotors

Up to 22 lb-in. continuous



24A-3F,  
Motor Base Mount

**90** COMPATIBLE WITH  
90 V CONTROLS

### Standard Features

- 24A motor provides high starting torque, adjustable speed, and predictable performance under a range of operating conditions. (see page 67 for more details)
- Industrial lip type seals on motor and output shafts
- Bronze sleeve bearing on output shaft for quietness
- Permanently lubricated gearing utilizing semi-fluid grease lubrication for long life
- Bronze gear for high shock load capability
- Hardened and ground worm for strength and long life

### Application Information

- For connection diagram 074 10101, see page 66
- Performance ratings of 130 V models based on use with filtered controls
- Gearmotors can be mounted via four holes in motor base
- Hollow shaft configurations are available. See Web site for mounting and shaft details. These models require lead time and minimum quantities.

### Matching Controls

- Bodine stocks a full line of speed controls for Bodine PMDC motors. See pages 86-99

Speed (rpm)	Rated Torque (lb-in.)	Rated Current (Amps)	Peak Torque (lb-in.)	HP	FF	Gear Ratio	Radial Load (lbs.)	Length (XH) (inch)	Wt. (lbs.)	Product Type	Model Number
<b>130V Models With Class B Ratings</b>											
42	22	.48	46	1/17	1.0	60	40	7.44	5.3	24A4BEPM-3F	N0089
63	19	.48	46	1/17	1.0	40	40	7.44	5.3	24A4BEPM-3F	<b>0088</b>
125	16	.48	32	1/17	1.0	20	5	7.44	5.3	24A4BEPM-3F	<b>0087</b>
250	10	.48	20	1/17	1.0	10	5	7.44	5.3	24A4BEPM-3F	<b>0086</b>
500	5.2	.48	10	1/17	1.0	5	5	7.44	5.3	24A4BEPM-3F	N0084

### 24A-3F Gearmotor

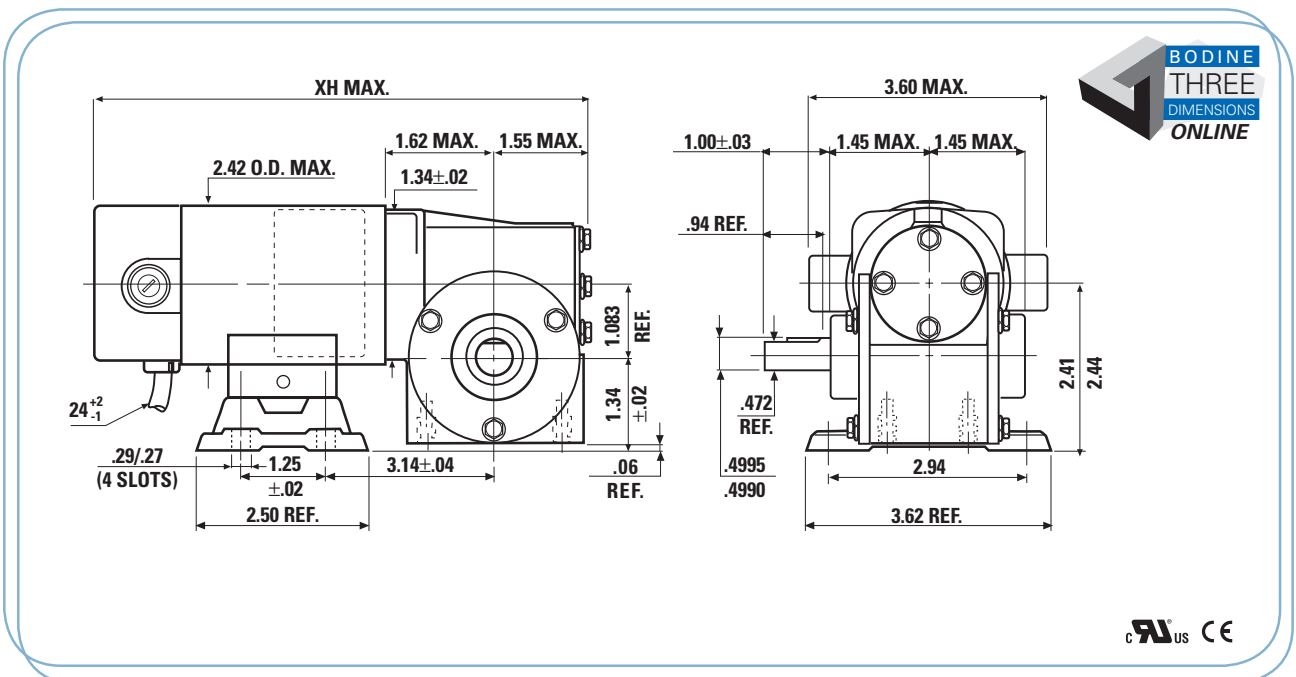

# Right Angle DC Gearmotors

## Up to 22 lb-in. continuous

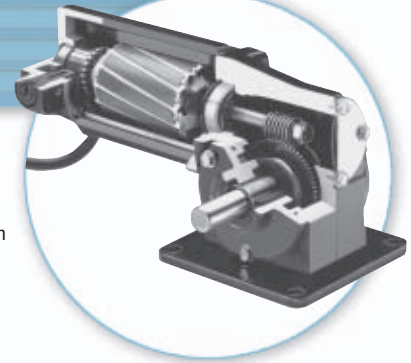

### Standard Features

- 24A motor provides high starting torque, adjustable speed, and predictable performance under a range of operating conditions. (see page 67 for more details)
- Industrial lip type seals on motor and output shafts
- Bronze sleeve bearing on output shaft for quietness
- Permanently lubricated gearing utilizing semi-fluid grease lubrication for long life
- Bronze gear for high shock load capability
- Hardened and ground worm for strength and long life

### Application Information

- For connection diagram 074 10101 see page 66
- Performance ratings of 130 V models based on use with filtered controls
- Gearmotors can be mounted via four tapped holes in bottom of gearhead
- Hollow shaft configurations are available. See page 14 for mounting and shaft details. Some models require lead time and minimum quantities.

### Optional Accessories

- Encoder model 0940, see page 101
- Baseplate kit model 0967, see page 100

### Matching Controls

- Bodine stocks a full line of speed controls for Bodine PMDC motors. See pages 86-99

24A-3F, Gearhousing Base Mount  
(shown with optional baseplate kit)



		Current @ Rated Torque (Amps)						Model Number <sup>1</sup>						
Speed (rpm)	Rated Torque (lb-in.)	24 Volt Winding	130 Volt Winding	Peak Torque (lb-in.)	Motor HP	Gear Ratio	Radial Load (lbs.)	Length XH (inch)	Weight (lbs.)	Product Type	24 Volt Winding		130 Volt Winding	
											Accessory Shaft	No Accessory Shaft	Accessory Shaft	No Accessory Shaft
42	22	2.6	.48	46	1/17	60	40	7.44	5.3	24A4BEPM-3F	N4899	N4699	N4099	<b>0099</b>
63	19	2.6	.48	46	1/17	40	40	7.44	5.3	24A4BEPM-3F	N4898	N4698	N4098	<b>0098</b>
125	16	2.6	.48	32	1/17	20	5	7.44	5.3	24A4BEPM-3F	N4896	N4696	N4096	<b>0096</b>
250	10	2.6	.48	20	1/17	10	5	7.44	5.3	24A4BEPM-3F	N4894	<b>4694</b>	N4094	<b>0094</b>
500	5.2	2.6	.48	10	1/17	5	5	7.44	5.3	24A4BEPM-3F	N4893	N4693	N4093	<b>0093</b>

<sup>1</sup> NOTE: Model numbers shown in bold type are in stock. "N" model numbers require lead time and minimum quantities.

24A-3F Gearmotor shown with optional baseplate kit (model 0967)

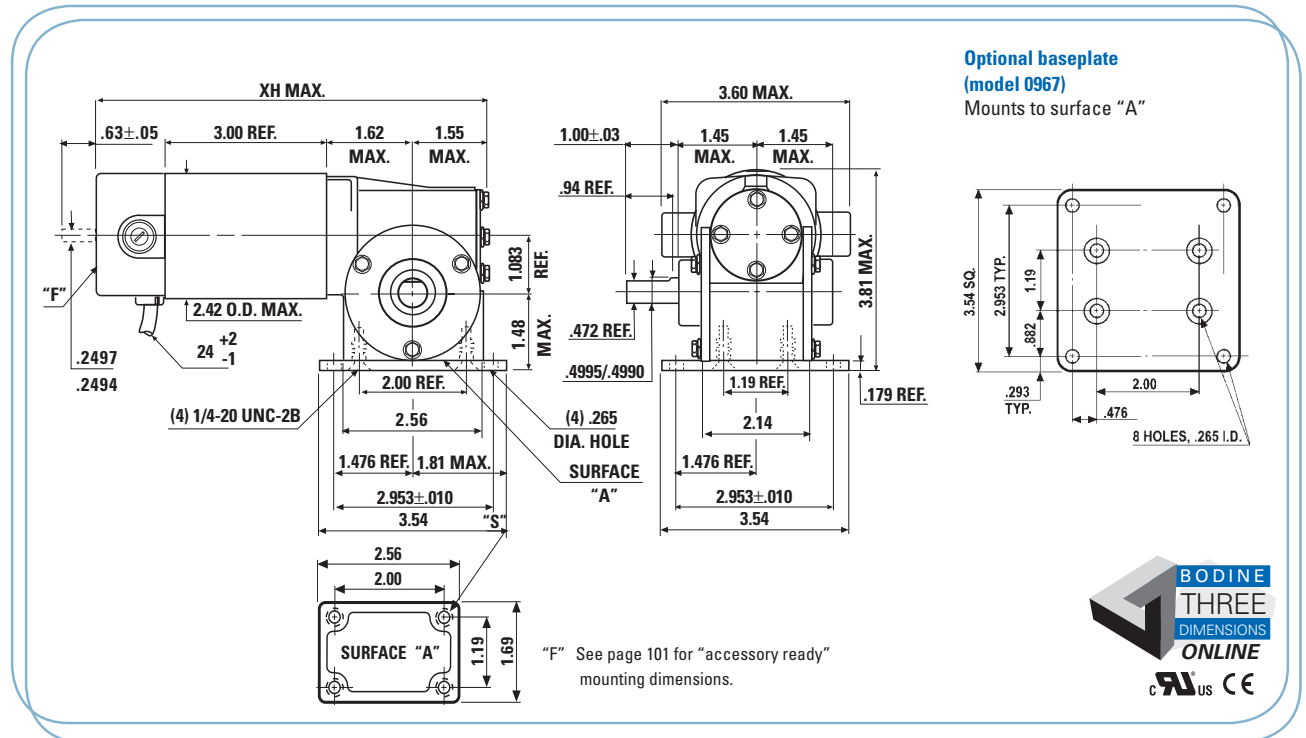

# Right Angle DC Gearmotors

Up to 77 lb-in. continuous



33A-5R, Motor Base Mount

### Standard Features

- 33A motor provides high starting torque, adjustable speed, and predictable performance under a range of operating conditions. (see page 68 for more details)
- Industrial lip type seals on motor and output shaft
- Bronze sleeve bearing on output shaft for quietness
- Permanently lubricated with high-performance lubricant
- Bronze gear for high shock load capability
- Hardened and ground worm for strength and long life

### Application Information

- For connection diagram 074 10101 see page 66
- Performance ratings of 130 V models based on use with filtered controls
- Gearmotors can be mounted via four holes in motor base
- Hollow shaft configurations are available. See Web site for mounting and shaft details. These models require lead time and minimum quantities.

### Optional Accessories

- IP-44 achieved with terminal box model 0984 or 1984, see page 100

### Matching Controls

- Bodine stocks a full line of speed controls for Bodine PMDC motors. See pages 86-99



Speed (rpm)	Rated Torque (lb-in.)	Rated Current (Amps)	Peak Torque (lbs-in.)	HP	FF	Gear Ratio	Radial Load (lbs.)	Length (XH) (inch)	Wt. (lbs.)	Product Type	Model Number
<b>130V Models, Class B, Grease Lubrication</b>											
50	45	0.71	118	1/12	1.0	40	80	8.96	9	33A3BEPM-5R	6128
67	41	0.71	83	1/12	1.0	30	80	8.96	9	33A3BEPM-5R	6127
100	29	0.71	44	1/12	1.0	20	80	8.96	9	33A3BEPM-5R	6126
200	17	0.71	23	1/12	1.0	10	80	8.96	9	33A3BEPM-5R	6125
<b>130V Models, Class F, Oil Lubrication</b>											
50	77	1.4	179	1/6	1.0	40	80	9.76	10.8	33A5BEPM-5L	6119
67	75	1.4	169	1/6	1.0	30	80	9.76	10.8	33A5BEPM-5L	6118
100	63	1.4	159	1/6	1.0	20	80	9.76	10.8	33A5BEPM-5L	6117
200	37	1.4	91	1/6	1.0	10	80	9.76	10.8	33A5BEPM-5L	6116

### 33A-5R / 33A-5L Gearmotor

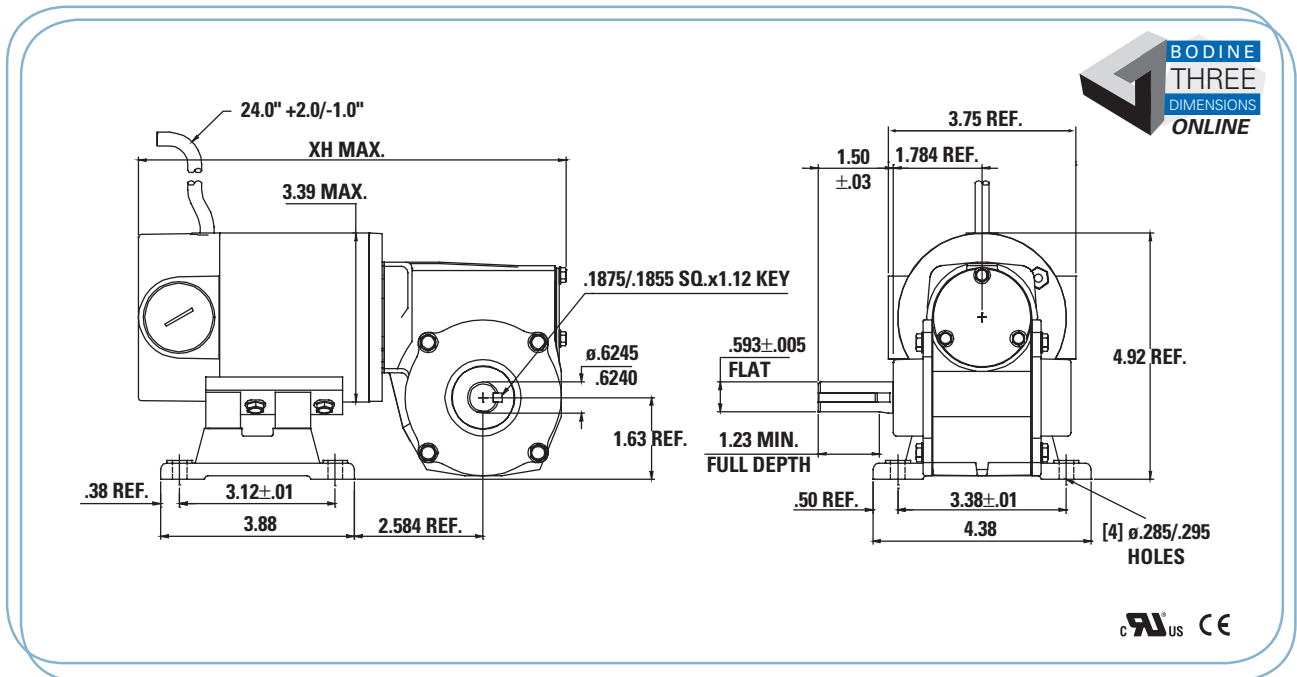



# Right Angle DC Gearmotors

Up to 109 lb-in. continuous

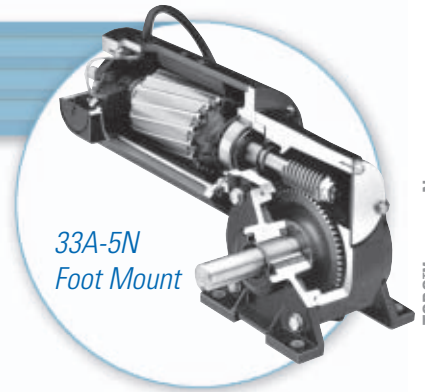

## Standard Features

- 33A motor provides high starting torque, adjustable speed, and predictable performance under a range of operating conditions. (see page 68 for more details)
- Industrial lip type seals on motor and output shaft
- Bronze sleeve bearing on output shaft for quietness
- Permanently lubricated with high-performance lubricant
- Bronze gear for high shock load capability
- Hardened and ground worm for strength and long life

## Application Information

- For connection diagram 074 10101 see page 66
- Performance ratings of 130 V models based on use with filtered controls
- Mounting feet are located on gearhead
- Hollow shaft configurations are available. See page 15 for mounting and shaft details. Some models require lead time and minimum quantities.

## Optional Accessories

- Encoder model 0941, see page 101
- Brake model 0997, see page 100
- IP-44 achieved with terminal box model 0984 or 1984, see page 100

## Matching Controls

- Bodine stocks a full line of speed controls for Bodine PMDC motors. See pages 86-99



Speed (rpm)	Rated Torque (lb-in.)	Rated Current (Amps)	Peak Torque (lb-in.)	HP	FF	Gear Ratio	Radial Load (lbs.)	Length (XH) (inch)	Wt. (lbs.)	Product Type	Model Number	
											Acc'y. Shaft	No Acc'y. Shaft
<b>24V Models With Class F Rating and Needle Bearings on Drivshaft</b>												
62	79	9.2	177	1/4	1.0	40	120	9.87	9.9	33A5BEPM-5N	<b>6835</b>	—
125	73	9.2	159	1/4	1.0	20	120	9.87	9.9	33A5BEPM-5N	—	<b>6636</b>
250	39	9.2	91	1/4	1.0	10	120	9.87	9.9	33A5BEPM-5N	—	<b>N6638</b>
<b>90V / 130V Models With Class F Ratings and Needle Bearings on Driveshaft</b>												
43 / 62	84 / 109	1.4 / 1.8	177	1/8 / 1/4	1.4 / 1.0	40	120	9.87	9.9	33A5BEPM-5N	—	<b>6138</b>
58 / 83	75 / 100	1.4 / 1.8	169	1/8 / 1/4	1.4 / 1.0	30	120	9.87	9.9	33A5BEPM-5N	—	<b>6137</b>
86 / 125	54 / 78	1.4 / 1.8	159	1/8 / 1/4	1.4 / 1.0	20	120	9.87	9.9	33A5BEPM-5N	—	<b>6136</b>
173 / 250	31 / 42	1.4 / 1.8	91	1/8 / 1/4	1.4 / 1.0	10	120	9.87	9.9	33A5BEPM-5N	<b>6535</b>	<b>6135</b>
345 / 500	17 / 22	1.4 / 1.8	49	1/8 / 1/4	1.4 / 1.0	5	120	9.87	9.9	33A5BEPM-5N	—	<b>6134</b>

**NOTE:** Model numbers shown in bold type are in stock. "N" model numbers require lead time and minimum quantities.

## 33A-5N Gearmotor

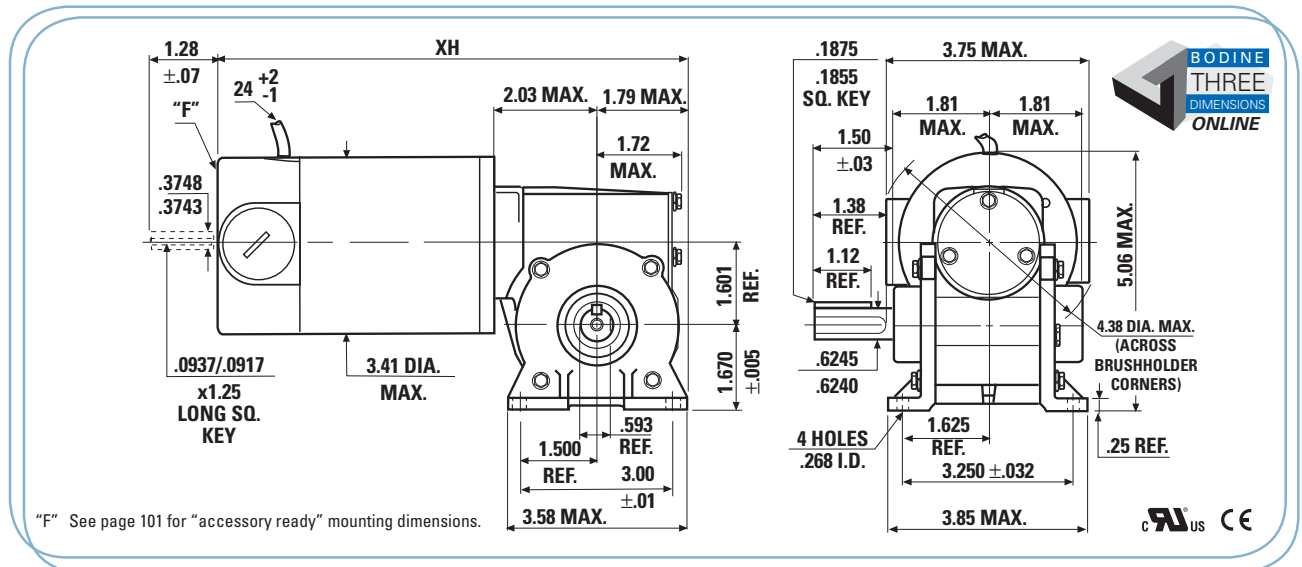

MADE IN U.S.A.

New  
e-TORQ™  
INTEGRAmotor™  
Hollow Shaft  
Custom  
Pacesetter™ Inverter Duty  
AC Induction  
Permanent Magnet DC  
Brushless DC  
Index

# Right Angle DC Gearmotors

Up to 77 lb-in. continuous



42A-5L, Motor Base Mount

**90** COMPATIBLE WITH 90 V CONTROLS

### Standard Features

- 42A motor provides high starting torque, adjustable speed, and predictable performance under a range of operating conditions. (see page 69 for more details)
- Industrial lip type seals on motor and output shafts
- Permanently lubricated with high-performance lubricant
- Bronze gear for high shock load capability
- Hardened and ground worm for strength and long life

### Application Information

- For connection diagram 074 10101 see page 66
- Performance ratings of 130 V models based on use with filtered controls
- Gearmotors mounted via four holes in motor base

### Optional Accessories

- IP-44 achieved with terminal box model 0984 or 1984, see page 100
- IP-44 achieved with boot kit model 0978, see page 100
- Hollow shaft configurations are available. See Website for mounting and shaft details. These models require lead time and minimum quantities.

### Matching Controls

- Bodine stocks a full line of speed controls for Bodine PMDC motors. See pages 86-99

Speed (rpm)	Rated Torque (lb-in.)	Rated Current (Amps)	Peak Torque (lb-in.)	HP	FF	Gear Ratio	Radial Load (lbs.)	Length (XH) (inch)	Wt. (lbs.)	Product Type	Model Number
<b>130V Models With Class B Ratings</b>											
50	77	1.3	177	1/6	1.0	40	80	9.97	14.1	42A4BEPM-5L	4119
67	75	1.3	169	1/6	1.0	30	80	9.97	14.1	42A4BEPM-5L	4118
100	63	1.3	159	1/6	1.0	20	80	9.97	14.1	42A4BEPM-5L	4117
200	37	1.3	91	1/6	1.0	10	80	9.97	14.1	42A4BEPM-5L	4116

### 42A-5L Gearmotor

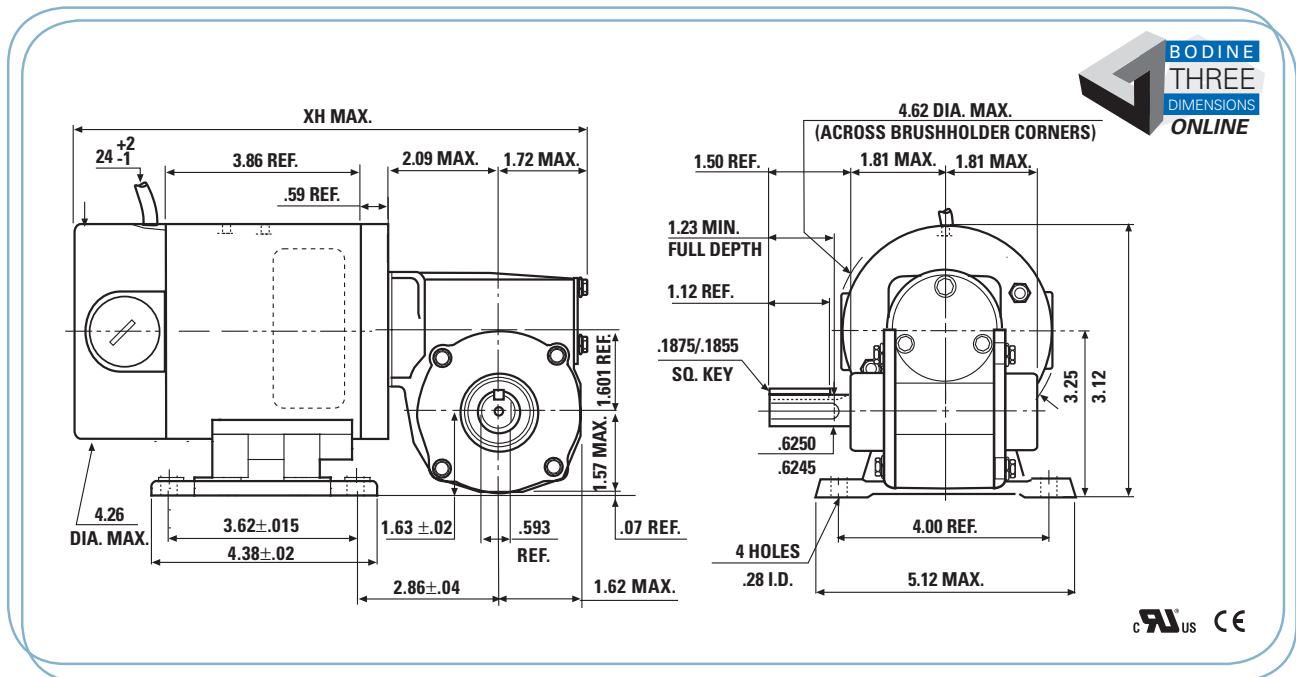

UL US CE

# Right Angle DC Gearmotors

Up to 79 lb-in. continuous



### Standard Features

- 42A motor provides high starting torque, adjustable speed, and predictable performance under a range of operating conditions. (see page 69 for more details)
- Industrial lip type seals on motor and output shafts
- Needle bearing on hardened output shaft journals for increased radial load capacity
- Permanently lubricated with high-performance lubricant
- Bronze gear for high shock load capability
- Hardened and ground worm for strength and long life

### Application Information

- For connection diagram 074 10101 see page 66
- Performance ratings of 130 V models based on use with filtered controls
- Mounting feet are located on gearhead
- Hollow shaft configurations are available. See page 16 for mounting and shaft details.

### Optional Accessories

- Encoder model 0941, see page 101
- Brake model 0997, see page 100
- IP-44 achieved with terminal box model 0984 or 1984, see page 100
- IP-44 achieved with boot kit model 0978, see page 100

### Matching Controls

- Bodine stocks a full line of speed controls for Bodine PMDC motors. See pages 86-99

**90 COMPATIBLE WITH 90 V CONTROLS**  
SEE PAGES 98 & 99

Speed (rpm)	Rated Torque (lb-in.)	Current @ Rated Torque (Amps)		Peak Torque (lb-in.)	Motor HP	Gear Ratio	Radial Load (lbs.)	Length XH (inch)	Weight (lbs.)	Product Type	Model Number <sup>1</sup>			
		24 Volt Winding	130 Volt Winding								24 Volt Winding		130 Volt Winding	
											Accessory Shaft	No Accessory Shaft	Accessory Shaft	No Accessory Shaft
62	79	8.8	1.8	177	1/4	40	120	10.37	14.3	42A5BEPM-5N	N4838	N4638	N4538	<b>4138</b>
83	75	8.8	1.8	169	1/4	30	120	10.37	14.3	42A5BEPM-5N	N4837	N4637	N4537	<b>4137</b>
125	75	8.8	1.8	159	1/4	20	120	10.37	14.3	42A5BEPM-5N	N4836	<b>4636</b>	<b>4536</b>	<b>4136</b>
250	42	8.8	1.8	91	1/4	10	120	10.37	14.3	42A5BEPM-5N	N4835	N4635	<b>4535</b>	<b>4135</b>
500	24	8.8	1.8	49	1/4	5	120	10.37	14.3	42A5BEPM-5N	N4834	N4634	N4534	<b>4134</b>

<sup>1</sup>NOTE: Model numbers shown in bold type are in stock. "N" model numbers require lead time and minimum quantities.

### 42A-5N Gearmotor

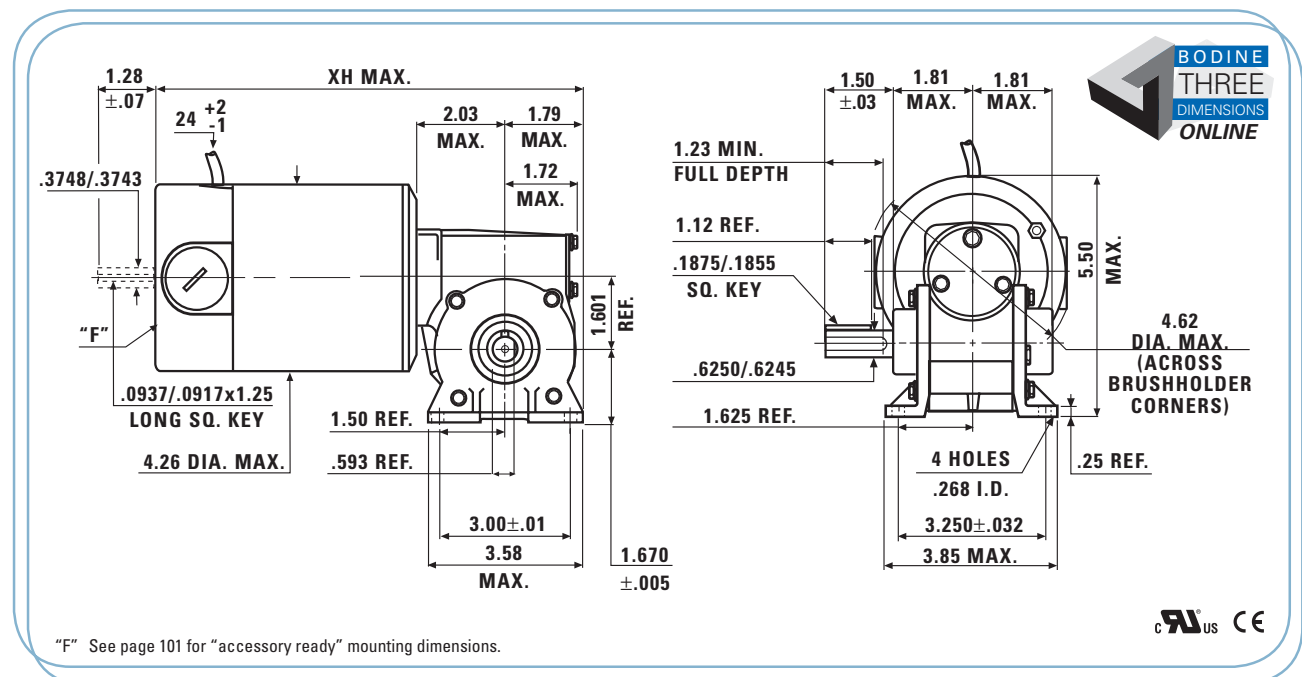

"F" See page 101 for "accessory ready" mounting dimensions.

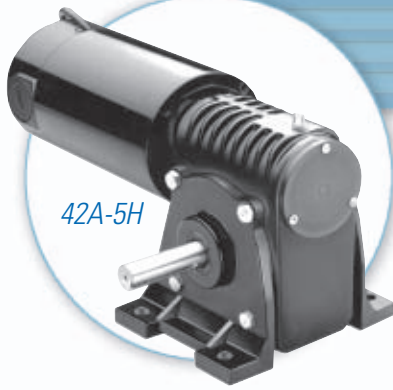

42A-5H

## Right Angle DC Gearmotors

Up to 264 lb-in. continuous

### Standard Features

- 42A motor provides high starting torque, adjustable speed, and predictable performance under a range of operating conditions. (see page 69 for more details)
- Rugged gearhead designed for heavy continuous loads with ample strength for shock loads
- Industrial lip type seals on motor and output shaft
- Ball bearing on output shaft for high radial and axial load capacity
- Permanently lubricated with high-performance lubricant
- Bronze gear for high shock load capability
- Hardened and ground worm for strength and long life

### Application Information

- For connection diagram 074 10101 see page 66
- Performance ratings of 130 V models based on use with filtered controls
- Mounting feet are located on gearhead

### Optional Accessories

- Encoder model 0941, see page 101
- Brake model 0997, see page 100
- IP-44 achieved with terminal box model 0984 or 1984, see page 100
- IP-44 achieved with boot kit model 0978, see page 100

### Matching Controls

- Bodine stocks a full line of speed controls for Bodine PMDC motors. See pages 86-99

**90 COMPATIBLE WITH 90 V CONTROLS**  
SEE PAGES 98 & 99

		Current @ Rated Torque (Amps)						Model Number <sup>1</sup>							
		24 Volt Winding	130 Volt Winding	Peak Torque (lb-in.)	Motor HP	Gear Ratio	Radial Load (lbs.)	Length XH (inch)	Weight (lbs.)	Product Type	24 Volt Winding		130 Volt Winding		
Speed (rpm)	Rated Torque (lb-in.)										Accessory Shaft	No Accessory Shaft	Accessory Shaft	No Accessory Shaft	
<b>Single Shaft Gearhead</b>															
52	189	12	2.3	340	1/3	48	150	13.00	24.4	42A7BEPM-5H	N4829	N4729	N4599	<b>4199</b>	
69	151	12	2.3	316	1/3	36	150	13.00	24.4	42A7BEPM-5H	N4828	N4728	N4598	<b>4198</b>	
139	87	12	2.3	186	1/3	18	150	13.00	24.4	42A7BEPM-5H	N4827	N4727	N4596	N4196	
250	52	12	2.3	104	1/3	10	150	13.00	24.4	42A7BEPM-5H	N4826	N4726	N4594	<b>4194</b>	
<b>Double Shaft Gearhead</b>															
52	264	15	3.4	340	1/2	48	150*	13.00	24.4	42A7BEPM-5H	N4833	N4733	N4503	N4103	
69	218	15	3.4	340	1/2	36	150*	13.00	24.4	42A7BEPM-5H	N4832	N4732	N4502	<b>4102</b>	
139	129	15	3.4	286	1/2	18	150*	13.00	24.4	42A7BEPM-5H	N4831	N4731	N4501	<b>4101</b>	
250	71	15	3.4	158	1/2	10	150*	13.00	24.4	42A7BEPM-5H	<b>4830</b>	N4730	N4500	N4100	

<sup>1</sup> NOTE: Model numbers shown in bold type are in stock. "N" model numbers require lead time and minimum quantities.

\* On only one of the two shafts.

42A-5H Gearmotor (model with accessory shaft and double shaft gearhead shown)

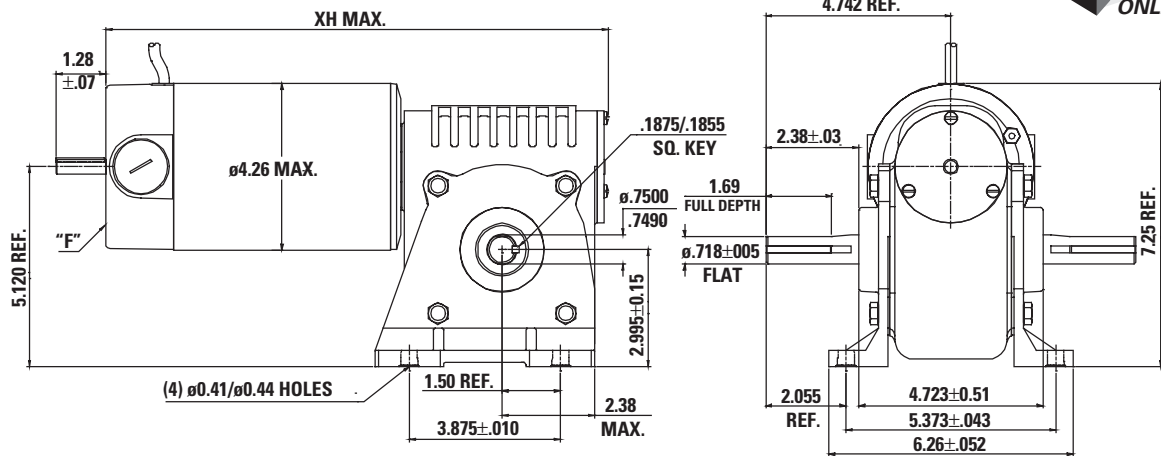

"F" See page 101 for "accessory ready" mounting dimensions.



# Right Angle DC Gearmotors

Up to 192 lb-in. continuous



33A-5H

### Standard Features

- 33A motor provides high starting torque, adjustable speed, and predictable performance under a range of operating conditions. (see page 68 for more details)
- Rugged gearhead designed for heavy continuous loads with ample strength for shock loads
- Industrial lip type seals on motor and output shaft
- Ball bearing on output shaft for high radial and axial load capacity
- Permanently lubricated with high-performance lubricant
- Bronze gear for high shock load capability
- Hardened and ground worm for strength and long life

### Application Information

- For connection diagram 074 10101 see page 66
- Mounting feet are located on gearhead

### Optional Accessories

- Encoder model 0941, see page 101
- Brake model 0997, see page 100
- IP-44 achieved with terminal box model 0984 or 1984, see page 100
- Hollow shaft configurations are available. See Website for mounting and shaft details. These models require lead time and minimum quantities.

### Matching Controls

- Bodine stocks a full line of speed controls for Bodine PMDC motors. See pages 86-99

**90** COMPATIBLE WITH 90 V CONTROLS

Speed (rpm)	Rated Torque (lb-in.)	Rated Current (Amps)	Peak Torque (lb-in.)	HP	FF	Gear Ratio	Radial Load (lbs.)	Length (XH) (inch)	Wt. (lbs.)	Product Type	Model Number	
											Acc'y. Shaft	No Acc'y. Shaft
<b>90V / 130V Models With Class F Ratings</b>												
36 / 52	137 / 192	1.8 / 2.4	340	1/6 / 1/3	1.4 / 1.0	48	150	12.53	18.2	33A7BEPM-5H	—	<b>6199</b>
48 / 69	113 / 158	1.8 / 2.4	316	1/6 / 1/3	1.4 / 1.0	36	150	12.53	18.2	33A7BEPM-5H	—	<b>6198</b>
96 / 139	67 / 93	1.8 / 2.4	186	1/6 / 1/3	1.4 / 1.0	18	150	12.53	18.2	33A7BEPM-5H	—	<b>6196</b>
173 / 250	37 / 52	1.8 / 2.4	104	1/6 / 1/3	1.4 / 1.0	10	150	12.53	18.2	33A7BEPM-5H	<b>6594</b>	<b>6194</b>

### 33A-5H Gearmotor

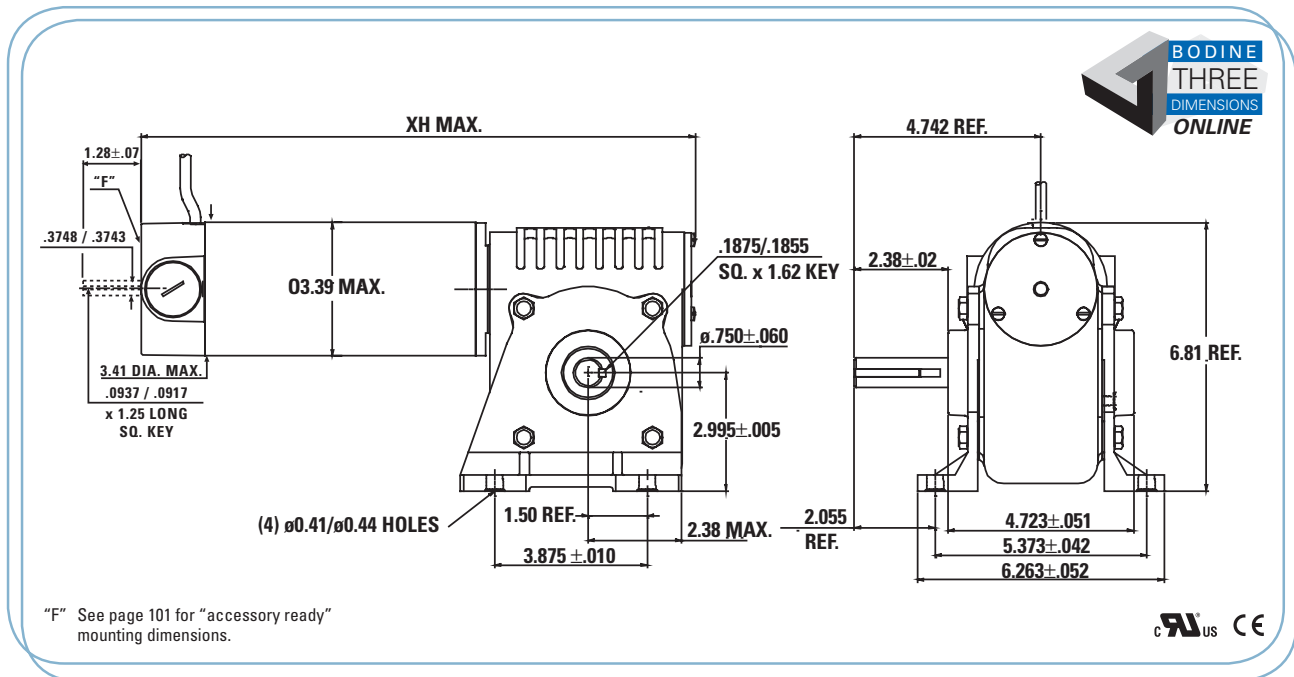

New  
e-TORQ™  
INTEGRAMOTOR™  
Hollow Shaft  
Custom  
Pacesetter™ Inverter Duty  
AC Induction  
Permanent Magnet DC  
Brushless DC  
Index

# Right Angle DC Gearmotors

Up to 380 lb-in. continuous

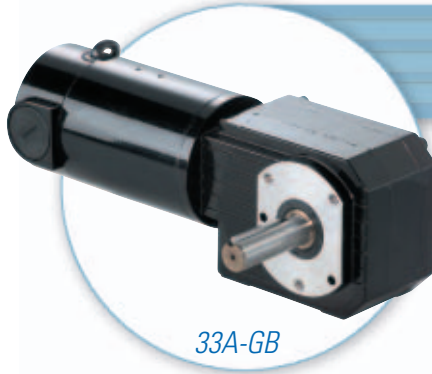

33A-GB

### Standard Features

- 33A motor provides high starting torque, adjustable speed, and predictable performance under a range of operating conditions. (see page 68 for more details)
- Industrial lip type seals on motor and output shafts
- Ball bearing on output shaft for increased radial load capacity and long life
- Permanently lubricated with high-performance lubricant
- Hardened helical output gearing for quietness and high output torque
- Bronze primary worm gear for high shock load capability
- Hardened and ground worm hobbled on the motor shaft for high strength and long life

### Application Information

- For connection diagram 074 10101 see page 66
- Mounting is via four tapped holes under the gearhead or three tapped holes in the face of the gearhead
- Hollow shaft configurations are available. See page 17 for mounting and shaft details.

### Optional Accessories

- IP-44 achieved with terminal box model 0984 or 1984, see page 100

### Matching Controls

- Bodine stocks a full line of speed controls for Bodine PMDC motors. See pages 86-99

**90** COMPATIBLE WITH 90 V CONTROLS

Speed (rpm)	Rated Torque (lb-in.)	Rated Current (Amps)	Peak Torque (lb-in.)	HP	FF	Gear Ratio	Radial Load	Length (XH) (inch)	Wt. (lbs.)	Product Type	Model Number
<b>90V / 130V Models With Class F Ratings</b>											
6.2 / 8.9	380 / 380	1.4 / 1.8	600	1/8 / 1/4	1.4 / 1.0	280	200	11.3	13.6	33A5BEPM-GB	6066
9.1 / 13	358 / 375	1.4 / 1.8	600	1/8 / 1/4	1.4 / 1.0	190	200	11.3	13.6	33A5BEPM-GB	6064
14 / 21	251 / 290	1.4 / 1.8	464	1/8 / 1/4	1.4 / 1.0	120	200	11.3	13.6	33A5BEPM-GB	6062
29 / 42	151 / 200	1.4 / 1.8	368	1/8 / 1/4	1.4 / 1.0	60	200	11.3	13.6	33A5BEPM-GB	6060

### 33A-GB Gearmotor

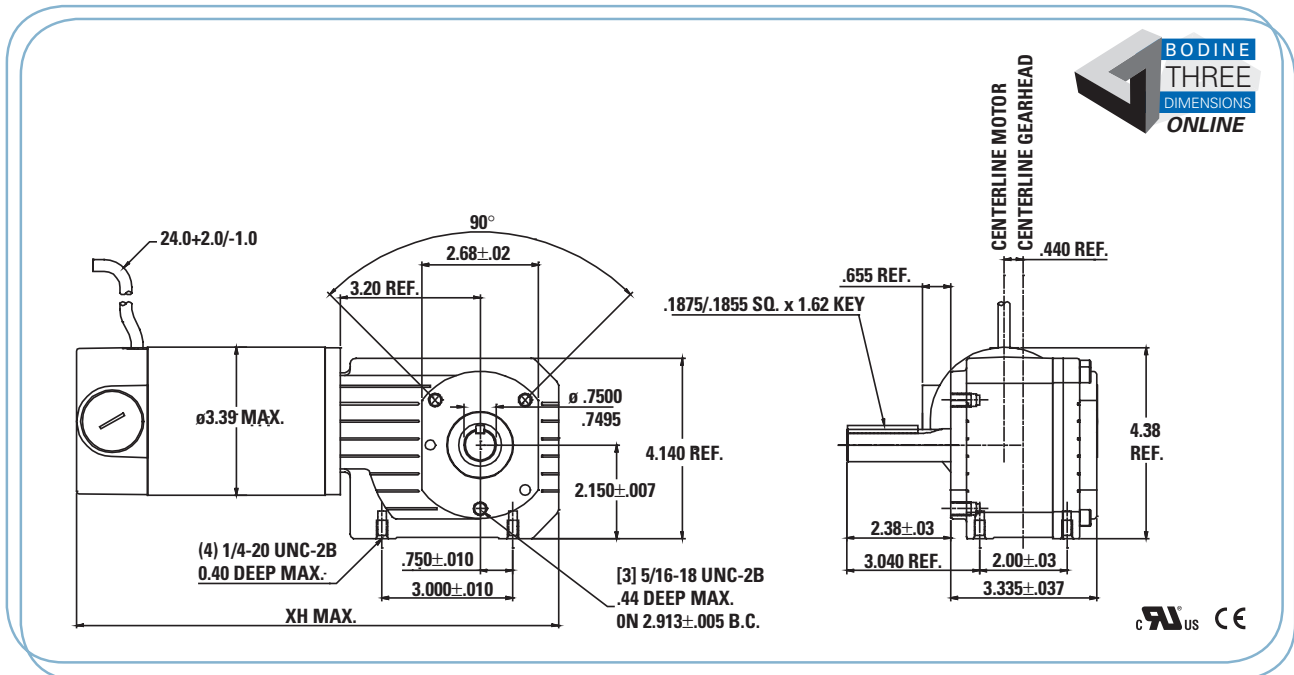

# Right Angle DC Gearmotors

Up to 380 lb-in. continuous

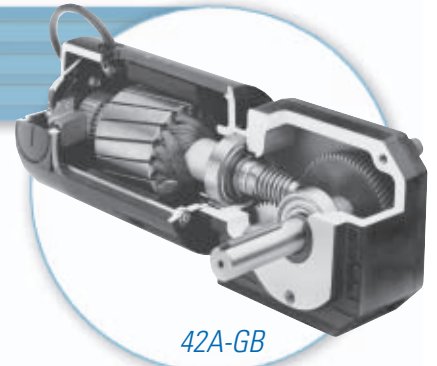

42A-GB

Cutaway view

### Standard Features

- 42A motor provides high starting torque, adjustable speed, and predictable performance under a range of operating conditions. (see page 69 for more details)
- Industrial lip type seals on motor and output shafts
- Ball bearing on output shaft for increased radial load capacity and long life
- Permanently lubricated with high-performance lubricant
- Hardened helical output gearing for quietness and high output torque
- Bronze primary worm gear for high shock load capability
- Hardened and ground worm hobbled on the motor shaft for high strength and long life

### Application Information

- For connection diagram 074 10101 see page 66
- Performance ratings of 130 V models based on use with filtered controls
- Mounting is via four tapped holes under the gearhead or three tapped holes in the face of the gearhead
- Hollow shafts available. See page 18

### Optional Accessories

- Encoder model 0941, see page 101
- Brake model 0997, see page 100
- IP-44 achieved with terminal box model 0984 or 1984, see page 100
- IP-44 achieved with boot kit model 0978, see page 100

### Matching Controls

- Bodine stocks a full line of speed controls for Bodine PMDC motors. See pages 86-99



Speed (rpm)	Rated Torque (lb-in.)	Current @ Rated Torque (Amps)		Peak Torque (lb-in.)	Motor HP	Gear Ratio	Radial Load (lbs.)	Length XH (inch)	Weight (lbs.)	Product Type	Model Number <sup>1</sup>			
		24 Volt Winding	130 Volt Winding								24 Volt Winding		130 Volt Winding	
											Accessory Shaft	No Accessory Shaft	Accessory Shaft	No Accessory Shaft
8.9	380	8.8	1.8	600	1/4	280	200	11.69	18	42A5BEPM-GB	N4866	N4766	N4466	<b>4066</b>
13	375	8.8	1.8	600	1/4	190	200	11.69	18	42A5BEPM-GB	N4864	N4764	N4464	<b>4064</b>
21	290	8.8	1.8	464	1/4	120	200	11.69	18	42A5BEPM-GB	N4862	N4762	N4462	<b>4062</b>
42	213	8.8	1.8	368	1/4	60	200	11.69	18	42A5BEPM-GB	N4860	N4760	N4460	<b>4060</b>

<sup>1</sup> NOTE: Model numbers shown in bold type are in stock. "N" model numbers require lead time and minimum quantities.



### 42A-GB Gearmotor

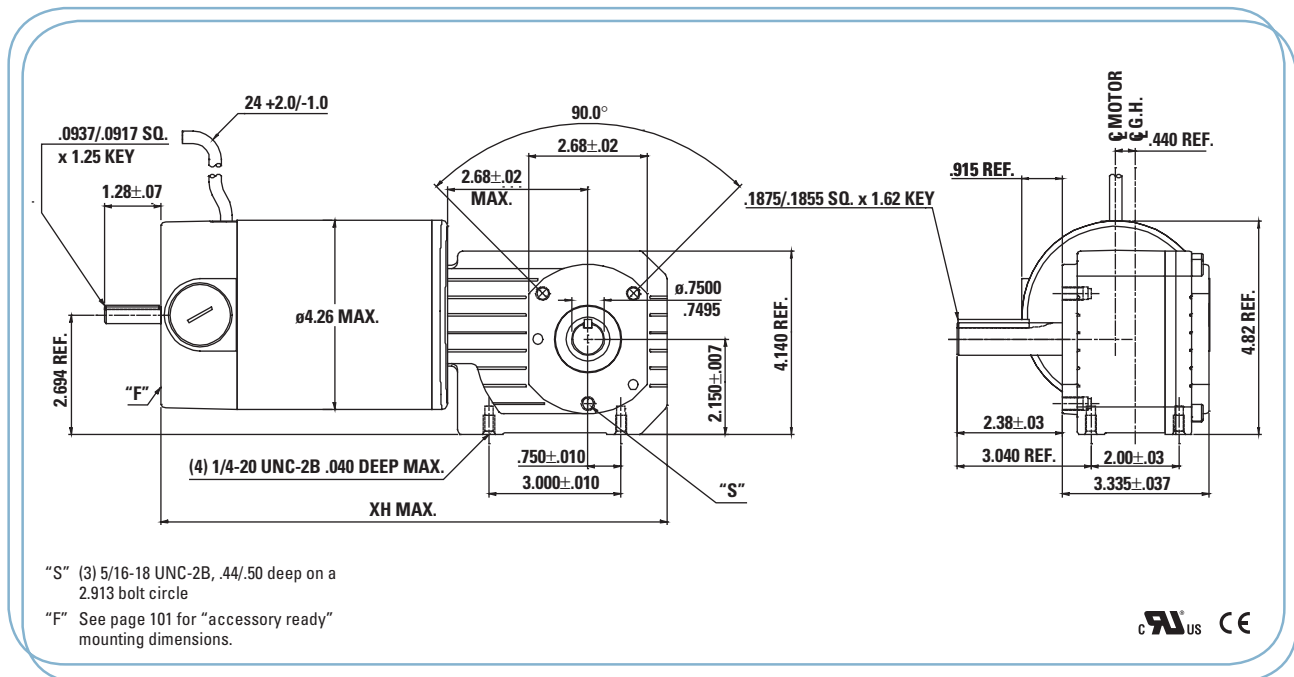

MADE IN U.S.A.

New e-TORQ™ INTEGRAMotor™ Hollow Shaft Custom Pacemaker™ Inverter Duty AC Induction Permanent Magnet DC Brushless DC Index

# DC Motor Controls

## Open Chassis Controls

See pages 88, 90, 94

**Types WPM, UPM and FPM**

For lowest cost and when an enclosure is already available



## NEMA 1 Enclosures

See pages 89, 91, 92, 93, and 95

**Types WPM, UPM and FPM**

With a convenient user interface and basic environmental protection



## NEMA 4 Enclosures

See page 87

**Type UPM**

For superior environmental protection against spraying water and windblown dust



## Advanced Interface Options

See pages 92, 93

**Type FPM**

For direction control or remote speed control



## Filtered Controls

See pages 88-93

**Type FPM and WPM**

For cooler motor operation and wider speed range

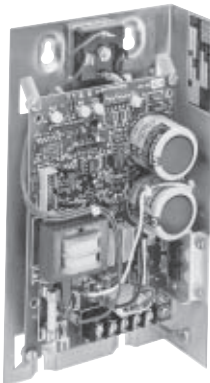

## Unfiltered Controls

See pages 87, 94, 95

**Type UPM**

Produce less EMI and draw less AC current





# Unfiltered SCR Motor Speed Control

## NEMA 4, Waterproof Enclosure

### Standard Features

- Operates from 115 Volt AC or 230 Volt AC line
- Switchable output for 0–90 Volt DC or 0–180 Volt DC
- Back EMF feedback maintains better than 2% speed regulation
- Dip switches to easily calibrate control for different motor sizes
- NEMA 4 enclosure for wet or dirty environments
- Trim pots on PC board to adjust torque limit, minimum speed limit, maximum speed limit, acceleration time, deceleration time, and speed regulation
- Speed can be adjusted manually using speed pot on front of enclosure

- Terminal block inside enclosure for quick line and motor connection
- Line fuses inside enclosure
- Toggle switch on front panel to turn AC power on/off
- Lamp on enclosure indicates when power is on
- Line filter inside enclosure to reduce conducted EMI

### Application Information

- Rated for continuous operation in 40° C ambient
- Drives Bodine 90/130 Volt and 180 Volt permanent magnet DC motors, or similar motors made by other manufacturers



New

e-TORQ™

INTEGRATOR™

Hollow Shaft

Custom

Pacesetter™ Inverter Duty

AC Induction

Permanent Magnet DC

Brushless DC

Index

HP Rating	Input Voltage (VAC, 50/60 Hz)	Output Voltage (VDC)	Continuous Output Current (Amps)	Peak Output Current (Amps)	Form Factor	Weight (lbs.)	Product Type	Model Number
1/5 @ 90V / 1/3 @ 180V	115 / 230	0 – 90 / 0 – 180	2.1	4.2	1.4	8.0	UPM-3318E4	1865



### Dimensions

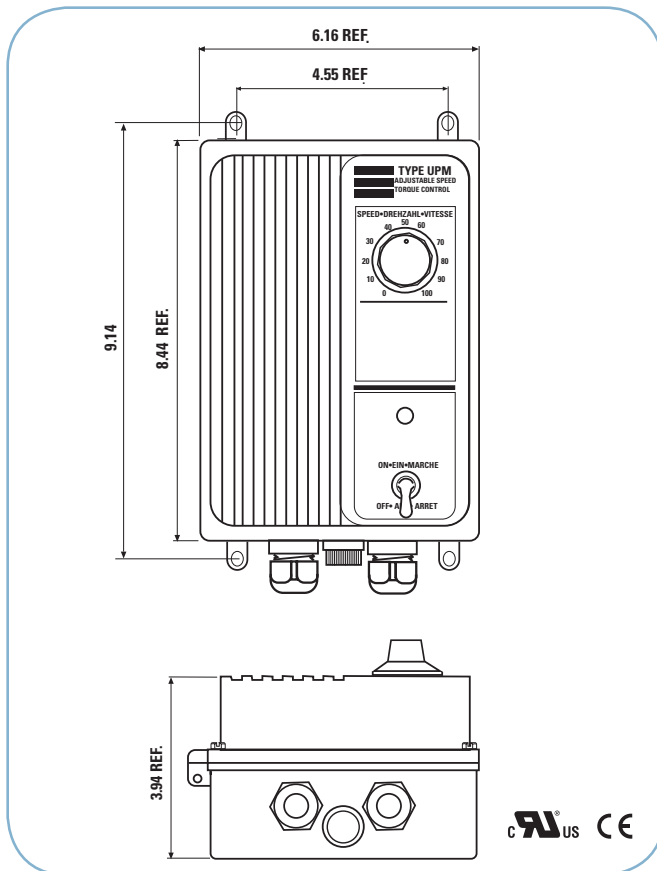

### Connection Diagram

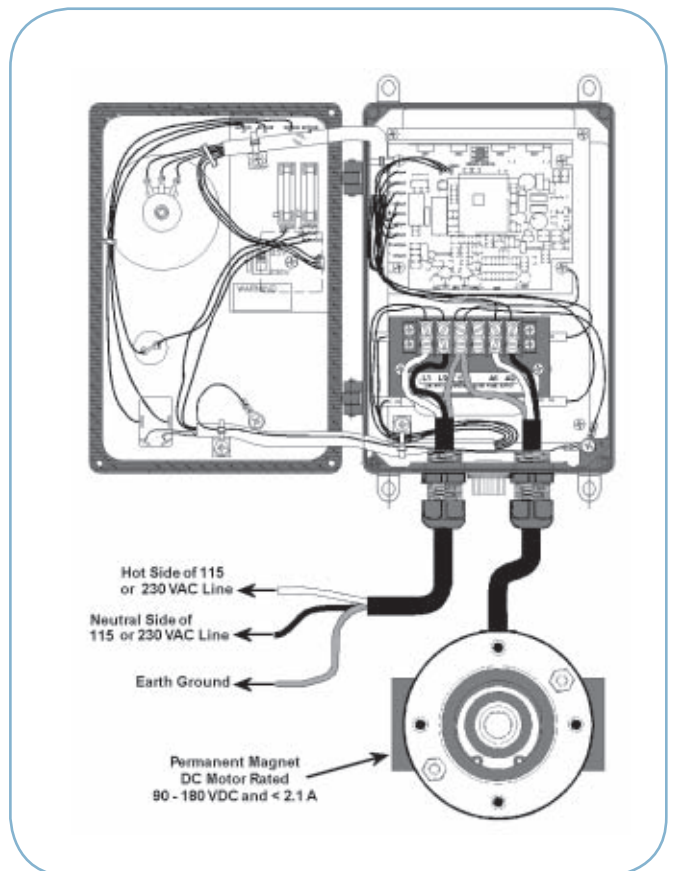

# Filtered PWM DC Controls

## Chassis, Basic Speed Control



**2 YEAR**  
SYSTEM WARRANTY  
SEE PAGE 128

### Standard Features

- Operates off 115 Volt AC line, 50/60 Hz
- Filtered DC output for cooler motor operation, longer brush life, lower audible noise, and wider speed range
- Back EMF feedback maintains better than 2% speed regulation
- Dip switches to easily calibrate control for different motor sizes
- Two diagnostic LEDs indicate when power is on and when current output is at limit set by TORQ pot
- Five on-board user-adjustable pots for torque limit, minimum speed limit, maximum speed limit, acceleration time, and speed regulation
- Speed can be adjusted manually using a remote 10k speed pot (included with control)
- Connections for optional user-supplied inhibit switch

### Application Information

- Rated for continuous operation in 40° C ambient with no additional heat sink
- Drives Bodine 130 Volt permanent magnet DC motors
- Drives 90 Volt "SCR rated" and 130 Volt "PWM rated" PM DC motors made by other manufacturers
- Connections made to models 0780 and 0781 with 0.25" quick connect tabs. Seven mating terminals supplied with control. Connections made to models 0783 and 0784 with pluggable terminal block (supplied with control)
- For selection tables see pages 96-99
- Line filter required to meet conditions for CE mark

### Optional Accessories

- Analog interface board and isolation module model 3984, see page 101

HP Rating	Input Voltage (VAC, 50/60 Hz)	Output Voltage (VDC)	Continuous Output Current (Amps)	Peak Output Current (Amps)	Form Factor	Weight (lbs.)	Product Type	Model Number	
								1/4 in. QC tab connection	Terminal block connection
1/6	115	0-130	1.25	2.50	1.0	1.0	WPM-2109C	0780	0783
7/16	115	0-130	3.20	5.00	1.0	1.0	WPM-2137C	0781	0784



### Dimensions

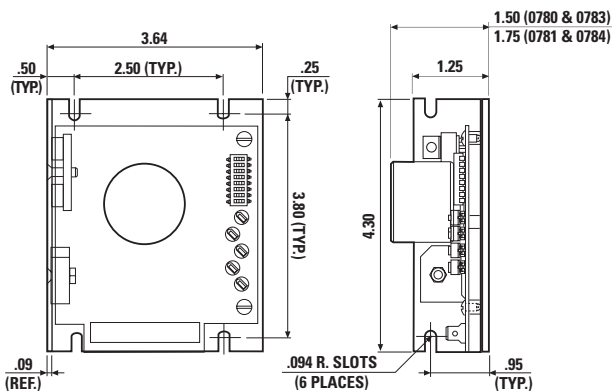

### Connection Diagram

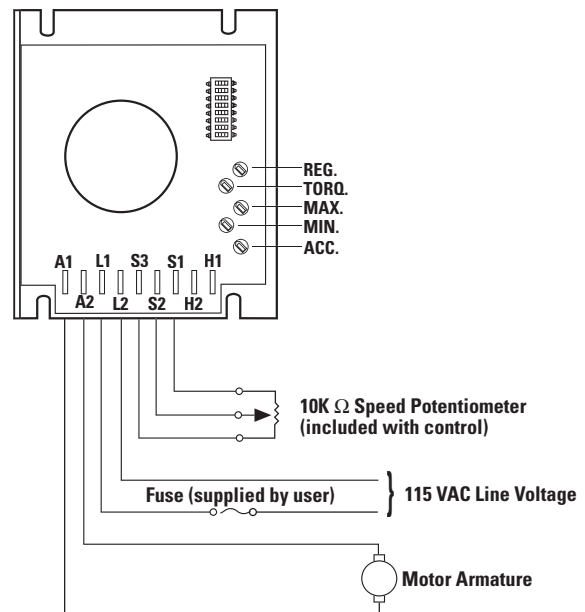

# Filtered PWM DC Controls

## NEMA 1, Basic Speed Control



WPM

**2 YEAR**  
SYSTEM WARRANTY  
SEE PAGE 128

### Standard Features

- Operates from 115 Volt AC line
- Filtered DC output for cooler motor operation, longer brush life, lower audible noise and wider speed range
- Dip switches to easily calibrate control for different motor sizes
- Line voltage compensation minimizes speed drift
- NEMA 1 enclosure for environmental protection
- Trim pots on PC board to adjust torque limit, minimum speed limit, maximum speed limit, acceleration time and speed regulation
- Speed can be adjusted manually using speed pot mounted on enclosure
- Terminal block inside enclosure for motor connection
- Back EMF feedback maintains better than 2% speed regulation
- Fuseholder for line on front panel

- Toggle switch on enclosure to turn AC power on/off
- Lamp on enclosure indicates AC power on
- AC line cable factory installed

### Application Information

- Rated for continuous operation in 40°C ambient with no additional heat sink
- Drives Bodine 130 Volt permanent magnet DC motors, see pages 67-85
- Drives 90 Volt "SCR duty" and 130 Volt "PWM duty" permanent magnet DC motors made by other manufacturers
- For selection tables see pages 96-99

HP Rating	Input Voltage (VAC, 50/60 Hz)	Output Voltage (VDC)	Continuous Output Current (Amps)	Peak Output Current (Amps)	Form Factor	Weight (lbs.)	Product Type	Model Number
1/6	115	0-130	1.25	2.50	1.0	2.0	WPM-2109E1	0790
7/16	115	0-130	3.2	5.00	1.0	2.0	WPM-2137E1	0791



### Dimensions

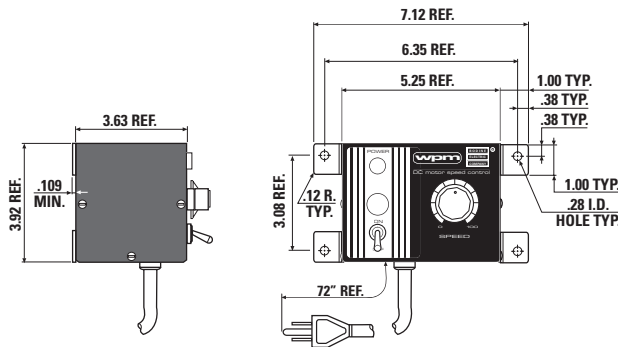

### Connection Diagram

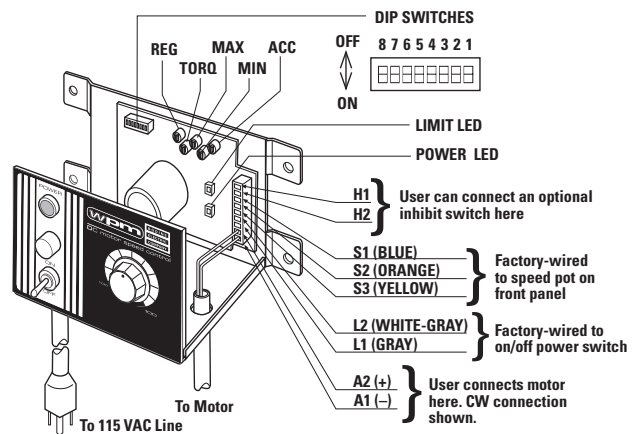

New

e-TORQ™

INTEGRATOR™

Hollow Shaft

Custom

Pacesetter™ Inverter Duty

AC Induction

Permanent Magnet DC

Brushless DC

Index

# Filtered SCR DC Controls

## Chassis, Basic Speed Control

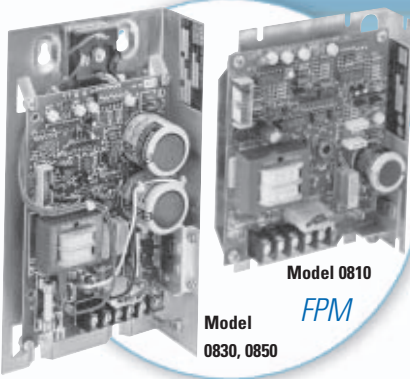

Model  
0830, 0850

Model 0810  
FPM

**2 YEAR**  
SYSTEM WARRANTY  
SEE PAGE 128

### Standard Features

- Operates off 115 Volt AC line
- Filtered DC output for cooler motor operation, longer brush life, lower audible noise, and wider speed range

- Dip switches to easily calibrate control for different motor sizes
- Line voltage and temperature compensation minimize speed drift
- Trim pots on PC board to adjust torque limit, minimum speed limit, maximum speed limit, acceleration time and speed regulation
- Back EMF feedback maintains better than 2% speed regulation
- 10k ohm remote speed pot and 24" connecting wire supplied with each control
- Connections for optional user-supplied inhibit switch
- Terminal block for quick line and motor connection
- Plug-in connector for speed pot and optional user-supplied inhibit switch
- Flexibility in adding plug-in interface boards, see optional accessories
- Built-in line and motor fuseholders (both fuses supplied)

### Application Information

- Rated for continuous operation in 50° C ambient with no additional heat sink
- Designed to be mounted in separate enclosure supplied by user
- Drives Bodine 130 Volt permanent magnet DC motors, see pages 67-85
- Drives 90 Volt "SCR duty" and 130 Volt "PWM duty" permanent magnet DC motors made by other manufacturers
- See page 96 for selection tables

### Optional Accessories

- Analog interface board model 0888, see page 101
- Digital Interface Board model 0889, see page 101
- Electronic Direction and Braking Board model 0890, see page 101
- Local/Remote Switch Kit model 0893, see page 101

HP Rating	Input Voltage (VAC, 50/60 Hz)	Output Voltage (VDC)	Continuous Output Current (Amps)	Peak Output Current (Amps)	Form Factor	Weight (lbs.)	Product Type	Model Number
1/17	115	0-130	0.50	1.0	1.0	2.5	FPM-0810C	0810
1/6	115	0-130	1.25	2.5	1.0	3.4	FPM-0830C	0830
1/3	115	0-130	2.30	4.6	1.0	4.0	FPM-0850C	0850



### Dimensions

Model 0810

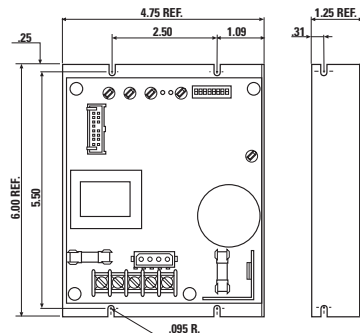

Models 0830, 0850

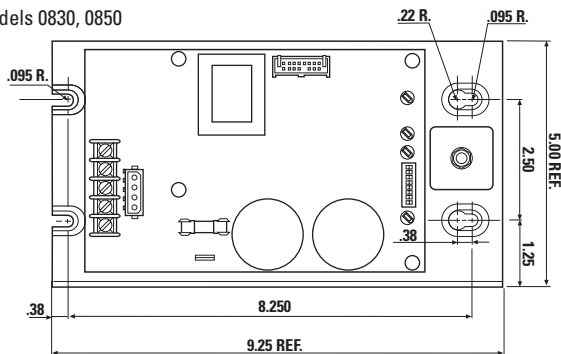

### Connection Diagram

Model 0810 shown. Models 0830 and 0850 are similar

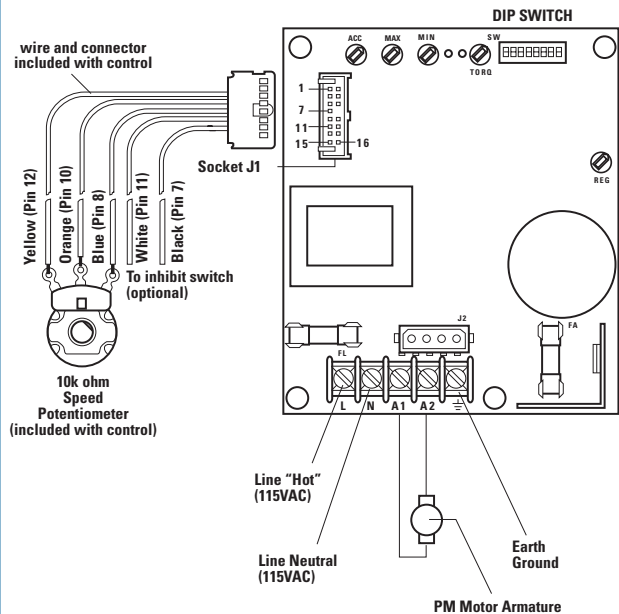

Note: Wire for line and motor connections must be supplied by user

# Filtered SCR DC Controls

## NEMA 12, Basic Speed Control



FPM

**2 YEAR**  
SYSTEM WARRANTY  
SEE PAGE 128

New

e-TORQ™

INTEGRATOR™

Hollow Shaft

Custom

Pacesetter™ Inverter Duty

AC Induction

Permanent Magnet DC

Brushless DC

Index

### Standard Features

- Operates from 115 Volt AC line
- Filtered DC output for cooler motor operation, longer brush life, lower audible noise and wider speed range
- Dip switches to easily calibrate control for different motor sizes
- Line voltage and temperature compensation minimize speed drift
- NEMA 12 enclosure for environmental protection
- Trim pots on PC board to adjust torque limit, minimum speed limit, maximum speed limit, acceleration time and speed regulation
- Speed can be adjusted manually using speed pot mounted on enclosure
- Terminal block inside enclosure for quick line and motor connection
- Back EMF feedback maintains better than 2% speed regulation

- Fuseholders for line and motor inside enclosure (both fuses supplied)
- Toggle switch on enclosure to turn AC power on/off
- Lamp on enclosure indicates AC power on

### Application Information

- Rated for continuous operation in 40° C ambient with no additional heat sink
- Drives Bodine 130 Volt permanent magnet DC motors, see pages 67-85
- Drives 90 Volt "SCR duty" and 130 Volt "PWM duty" permanent magnet DC motors made by other manufacturers
- For selection tables see page 96

### Optional Accessories

- IP-44 sealing kit model 0895 for protection against splashing water, see page 101

HP Rating	Input Voltage (VAC, 50/60 Hz)	Output Voltage (VDC)	Continuous Output Current (Amps)	Peak Output Current (Amps)	Form Factor	Weight (lbs.)	Product Type	Model Number
1/17	115	0-130	0.50	1.00	1.0	8.0	FPM-0815E	0815
1/6	115	0-130	1.25	2.50	1.0	8.0	FPM-0835E	0835
1/3	115	0-130	2.30	4.60	1.0	8.0	FPM-0855E	0855

### Dimensions

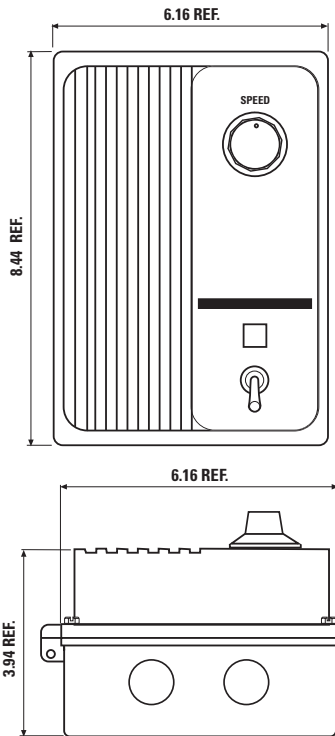

Accepts .5 in. liquid tight fittings

### Connection Diagram

Shown with enclosure door removed

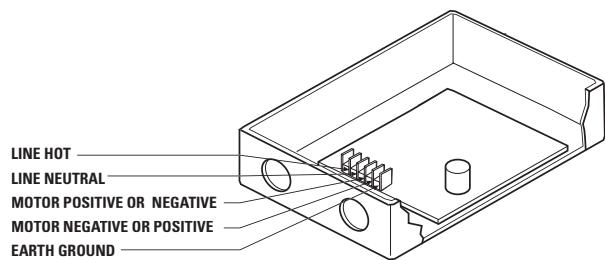

Note: All wires external to control must be supplied by user

# Filtered SCR DC Controls

## NEMA 12, Speed and Direction Control



FPM

**2 YEAR**  
SYSTEM WARRANTY  
SEE PAGE 128

### Standard Features

- Operates from 115 Volt AC line
- Filtered DC output for cooler motor operation, longer brush life, lower audible noise and wider speed range

- Dip switches to easily calibrate control for different motor sizes
- Line voltage and temperature compensation minimize speed drift
- NEMA 12 enclosure for environmental protection
- Dynamic braking for quick stops
- Trim pots on PC board to adjust torque limit, minimum speed limit, maximum speed limit, acceleration time and speed regulation
- Speed can be adjusted manually using speed pot mounted on enclosure
- Toggle switch on enclosure to turn AC power on/off
- Rotary switch on enclosure for direction
- Lamp on enclosure indicates AC power on
- Terminal block inside enclosure for quick line and motor connection
- Back EMF feedback maintains better than 2% speed regulation
- Fuseholders for line and motor inside enclosure (fuses included)

### Application Information

- Rated for continuous operation in 40° C ambient with no additional heat sink
- Drives Bodine 130 Volt permanent magnet DC motors, see pages 67-85
- Drives 90 Volt "SCR duty" and 130 Volt "PWM duty" permanent magnet DC motors made by other manufacturers
- For selection table, see page 96

### Optional Accessories

- IP-44 sealing kit model 0895 for protection against splashing water, see page 101

HP Rating	Input Voltage (VAC, 50/60 Hz)	Output Voltage (VDC)	Continuous Output Current (Amps)	Peak Output Current (Amps)	Form Factor	Weight (lbs.)	Product Type	Model Number
1/17	115	0-130	0.50	1.00	1.0	8.0	FPM-0818E	<b>0818</b>
1/6	115	0-130	1.25	2.50	1.0	8.0	FPM-0838E	<b>0838</b>
1/3	115	0-130	2.30	4.60	1.0	8.0	FPM-0858E	<b>0858</b>

### Dimensions

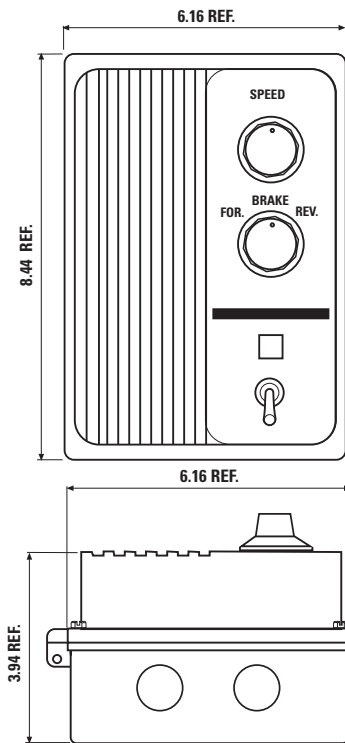

Accepts .5 in. liquid tight fittings

### Connection Diagram



Assembly shown exploded for clarity

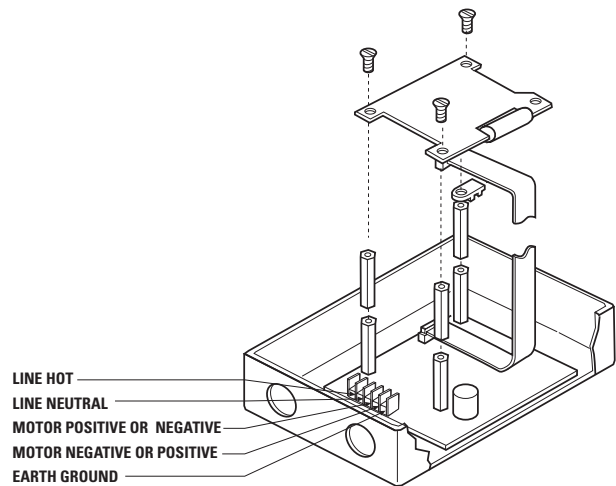

Note: All wires external to control must be supplied by user

# Filtered SCR DC Controls

## NEMA 12, Remote Speed Control



FPM

**2 YEAR**  
SYSTEM WARRANTY  
SEE PAGE 128

**BODINE**  
**THREE**  
DIMENSIONS  
**ONLINE**

### Standard Features

- Operates from 115 Volt AC line
- Filtered DC output for cooler motor operation, longer brush life, lower audible noise and wider speed range
- Dip switches to easily calibrate control for different motor sizes
- Line voltage and temperature compensation minimize speed drift
- NEMA 12 enclosure for environmental protection
- Trim pots on PC board to adjust torque limit, minimum speed limit, maximum speed limit, acceleration time, and speed regulation
- Speed can be adjusted manually using speed pot mounted on enclosure
- Terminal block inside enclosure for quick line and motor connection

- Back EMF feedback maintains better than 2% speed regulation
- Fuseholders for line and motor inside enclosure (fuses included)

### Application Information

- Rated for continuous operation in 40° C ambient with no additional heat sink
- Drives Bodine 130 Volt permanent magnet DC motors, see pages 67-85
- Drives 90 Volt "SCR duty" and 130 Volt "PWM duty" permanent magnet DC motors made by other manufacturers
- For selection table, see page 96

### Optional Accessories

- IP-44 sealing kit model 0895 for protection against splashing water, see page 101

HP Rating	Input Voltage (VAC, 50/60 Hz)	Output Voltage (VDC)	Continuous Output Current (Amps)	Peak Output Current (Amps)	Form Factor	Weight (lbs.)	Remote Signal	Product Number	Model Number <sup>1</sup>
1/17	115	0-130	0.50	1.00	1.0	8.0	Analog	FPM-0816E	<b>0816</b>
1/17	115	0-130	0.50	1.00	1.0	8.0	Digital	FPM-0817E	N0817
1/6	115	0-130	1.25	2.50	1.0	8.0	Analog	FPM-0836E	<b>0836</b>
1/6	115	0-130	1.25	2.50	1.0	8.0	Digital	FPM-0837E	N0837
1/3	115	0-130	2.30	4.60	1.0	8.0	Analog	FPM-0856E	<b>0856</b>
1/3	115	0-130	2.30	4.60	1.0	8.0	Digital	FPM-0857E	N0857

<sup>1</sup> NOTE: Model numbers shown in bold type are in stock. "N" model numbers require lead time and minimum quantities.

### Dimensions

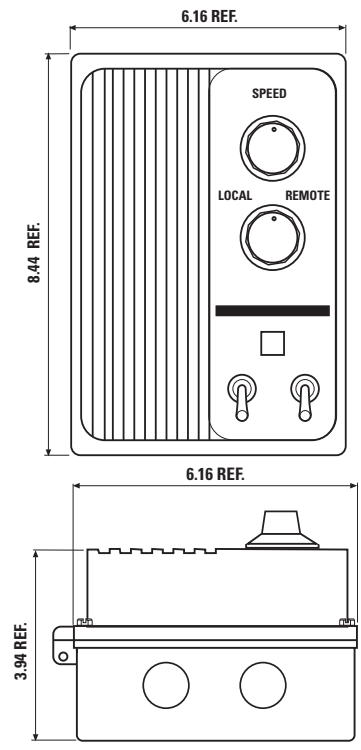

Accepts .5 in. liquid tight fittings

### Connection Diagram

Assembly shown exploded for clarity

#### ANALOG INTERFACE

- SIGNAL COMMON
- START INPUT
- STOP INPUT
- SPEED INPUT

— OR —

#### DIGITAL INTERFACE

- SIGNAL COMMON
- LATCH INPUT
- SPEED BIT 1
- SPEED BIT 2
- SPEED BIT 3
- SPEED BIT 4
- SPEED BIT 5
- SPEED BIT 6
- SPEED BIT 7

- LINE HOT
- LINE NEUTRAL
- MOTOR POSITIVE OR NEGATIVE
- MOTOR NEGATIVE OR POSITIVE
- EARTH GROUND

All wires external to control must be supplied by user

**BODINE**  
**ELECTRIC**  
**COMPANY**

**MADE IN U.S.A.**

New  
e-TORQ™  
INTEGRATOR™  
Hollow Shaft  
Custom  
Pacesetter™ Inverter Duty  
AC Induction  
Permanent Magnet DC  
Brushless DC  
Index

# Unfiltered SCR DC Controls

## Chassis, Basic Speed Control

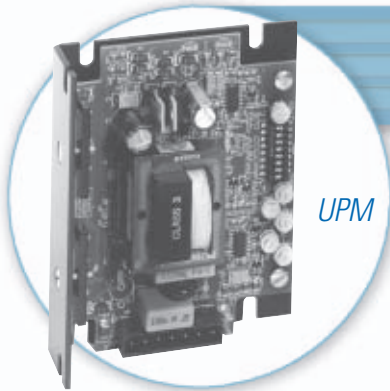

UPM

**2 YEAR**  
SYSTEM WARRANTY  
SEE PAGE 128

### Standard Features

- Operates from 115 Volt AC or 230 Volt AC line, selectable with plug-in jumper
- Switchable output for 0-90 Volt DC or 0-180 Volt DC

- Back EMF feedback maintains better than 2% speed regulation
- Dip switches to easily calibrate control for different motor sizes
- Two diagnostic LEDs indicate when power is on and when current output is at limit set by TORQ pot
- Six on-board user-adjustable pots for torque limit, minimum speed limit, maximum speed limit, acceleration time, deceleration time and speed regulation
- Speed can be adjusted manually using a remote 10K speed pot (included with control)
- Unfiltered drive draws lower AC line current as compared to SCR filtered controls
- Connections for optional user-supplied inhibit switch

### Application Information

- Rated for continuous operation in 50° C ambient with no additional heat sink
- Drives Bodine 130 Volt and 180 Volt permanent magnet DC motors, see pages 67-85
- Drives 90 Volt and 180 Volt "SCR rated" and 130 Volt "PWM rated" permanent magnet DC motors made by other manufacturers
- Connections made to model 0865 with 0.25" quick connect tabs. Seven mating terminals supplied with control. Connections made to model 0866 with plug-gable terminal block (supplied with control)
- For selection table, see pages 98-99

### Optional Accessories

- Analog interface board and isolation module model 3984, see page 101

HP Rating	Input Voltage (VAC, 50/60 Hz)	Output Voltage (VDC)	Continuous Output Current (Amps)	Peak Output Current (Amps)	FF	Weight (lbs.)	Product Type	Model Number	
								1/4 inch QC tab connection	Terminal block connection
1/5 @ 90 V	115/230	0-90/0-180	2.1	4.2	1.6	1.0	UPM-3318C	0865	0866
1/3 @ 180 V	115/230	0-90/0-180	2.1	4.2	1.6	1.0	UPM-3318C	0865	0866



### Dimensions

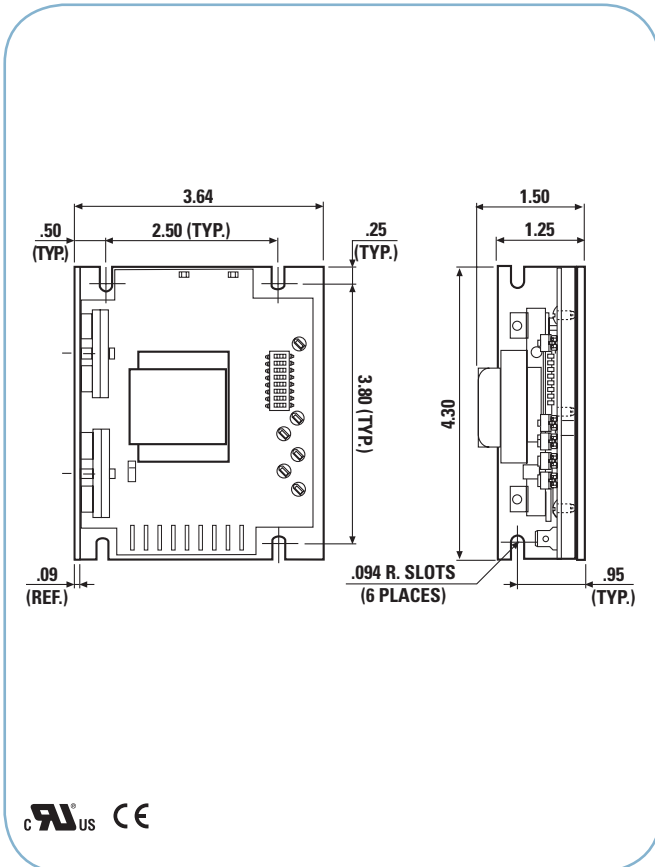

### Connection Diagram

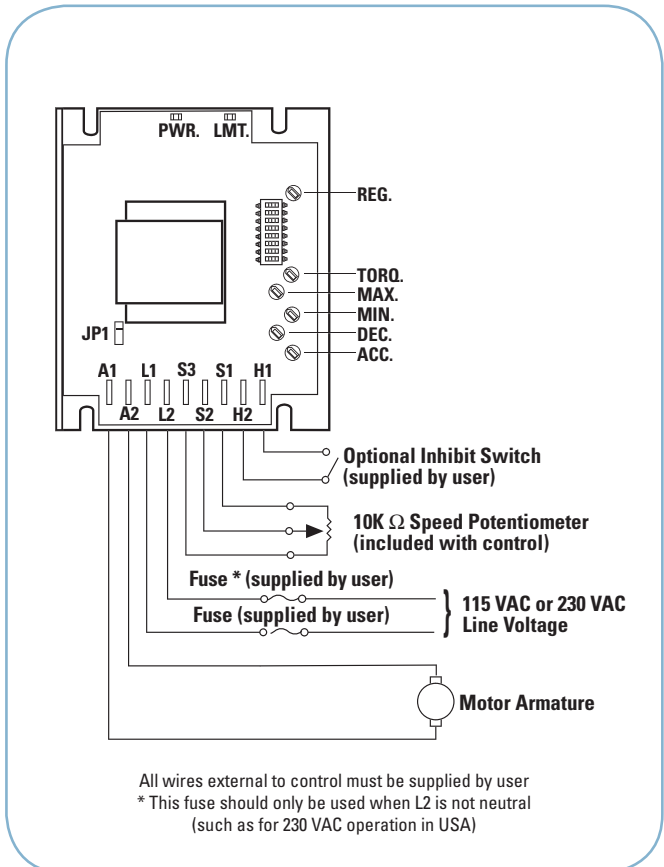



# Unfiltered SCR DC Controls

## NEMA 1, Basic Speed Control



UPM

**2 YEAR**  
SYSTEM WARRANTY  
SEE PAGE 128

New

e-TORQ™

INTEGRAmotor™

Hollow Shaft

Custom

Pacesetter™ Inverter Duty

AC Induction

Permanent Magnet DC

Brushless DC

Index

### Standard Features

- Operates from 115 Volt AC line
- Dip switches to easily calibrate control for different motor sizes
- Line voltage compensation minimizes speed drift
- NEMA 1 enclosure for environmental protection
- Trim pots on PC board to adjust torque limit, minimum speed limit, maximum speed limit, acceleration time, deceleration time and speed regulation
- Speed can be adjusted manually using speed pot mounted on enclosure
- Terminal block inside enclosure for quick motor connection
- Back EMF feedback maintains better than 2% speed regulation

- Fuseholder for line on front panel
- Toggle switch on enclosure to turn AC power on/off
- Lamp on enclosure indicates AC power on
- AC Line cord factory installed

### Application Information

- Rated for continuous operation in 40° C ambient with no additional heat sink
- Drives Bodine 130 Volt permanent magnet DC motors at reduced speed, see pages 67-85
- Drives 90 Volt "SCR duty" and 130 Volt "PWM duty" permanent magnet DC motors made by other manufacturers
- For selection tables see pages 98-99

HP Rating	Input Voltage (VAC, 50/60 Hz)	Output Voltage (VDC)	Continuous Output Current (Amps)	Peak Output Current (Amps)	Form Factor	Weight (lbs.)	Product Type	Model Number
1/5	115	0-90	2.1	4.2	1.6	2.0	UPM-3318E1	0867

### Dimensions

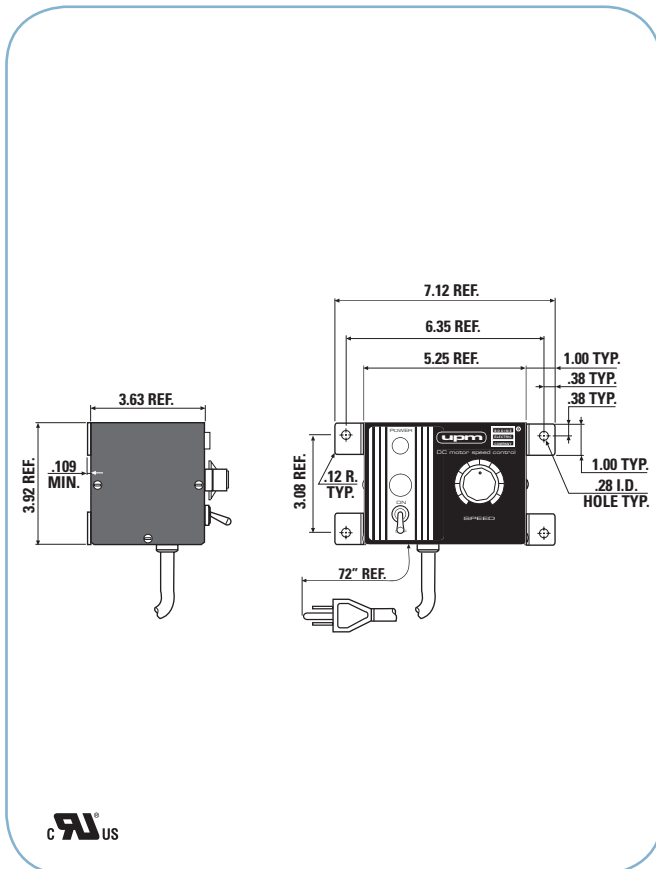

### Connection Diagram

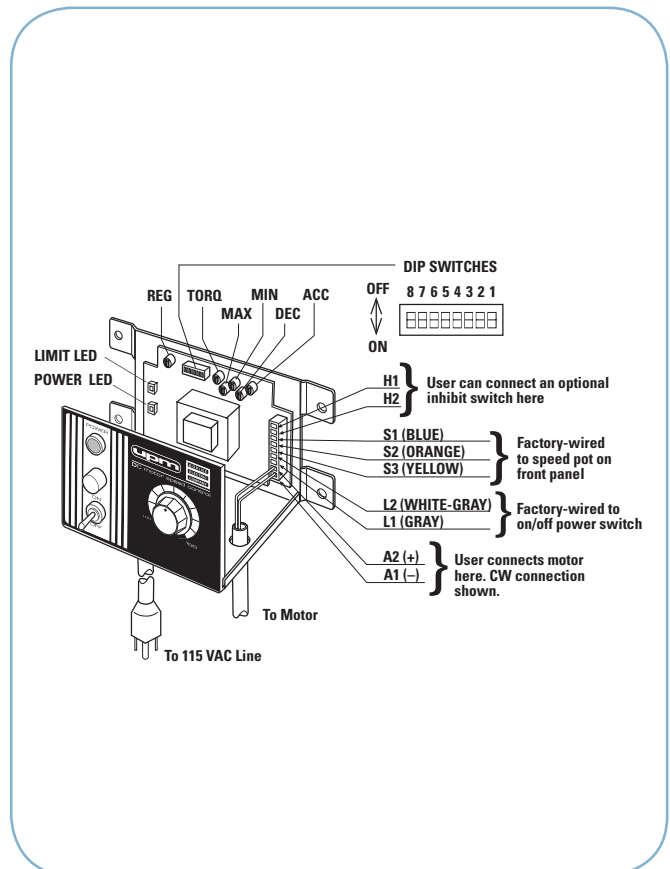

# Filtered DC Controls

## FPM and WPM Selection Table

### SYSTEM PERFORMANCE WHEN USING BODINE 130V PM MOTORS WITH FILTERED CONTROLS

Motor/Gearmotor Specifications							Matching Control Model Numbers							
Speed Range (rpm)	Cont. Torque (lb-in.)	Model Number		Product Type Shaft	Nameplate Rating (HP)	Ref. Page	Encased				Chassis			
		Accessory Shaft	No Accessory Shaft				Basic		Direction + Braking	Analog Signal	Digital Signal	SCR	PWM	
							SCR	PWM					Quick Connect Tabs	Term. Block
<b>Motors Without Gear Reducers</b>														
40 - 2500	0.5	N4439	N0039	24A0BEPM	1/50	67	0815	0790	0818	0816	N0817	0810	0780	0783
50 - 2500	0.88	N4441	0041	24A2BEPM	1/29	67	0815	0790	0818	0816	N0817	0810	0780	0783
50 - 2500	1.5	0047	0043	24A4BEPM	1/17	67	0815	0790	0818	0816	N0817	0810	0780	0783
60 - 2500	2.1	N6416	6016	33A3BEPM	1/12	68	0835	0790, 0791	0838	0836	N0837	0830	0780, 0781	0783, 0784
60 - 2500	3.1	N6420	6020	33A5BEPM	1/8	68	0835	0790, 0791	0838	0836	N0837	0830	0780, 0781	0783, 0784
60 - 2500	6.3	4435	4035	42A5BEPM	1/4	69	0855	0791	0858	0856	N0857	0850	0781	0784
60 - 2500	8.4	N4437	4037	42A7BEPM	1/3	69	0855	0791	0858	0856	N0857	0850	0781	0784
60 - 2500	9.4	N4430	4031	42A5BEPM	1/3	69	–	0791	–	–	–	–	0781	0784
60 - 2500	11.2	N4432	4033	42A7BEPM	1/2	69	–	0791	–	–	–	–	0781	0784
<b>Parallel Shaft Gearmotors</b>														
0.11 - 5.6	40	N4499	0199	24A2BEPM-D5	1/29	70	0815	0790	0818	0816	N0817	0810	0780	0783
0.17 - 8.3	40	N4498	0198	24A2BEPM-D5	1/29	70	0815	0790	0818	0816	N0817	0810	0780	0783
0.28 - 14	40	N4497	0197	24A2BEPM-D4	1/29	70	0815	0790	0818	0816	N0817	0810	0780	0783
0.56 - 28	40	N4496	0196	24A2BEPM-D4	1/29	70	0815	0790	0818	0816	N0817	0810	0780	0783
0.83 - 42	36	N4495	0195	24A2BEPM-D3	1/29	70	0815	0790	0818	0816	N0817	0810	0780	0783
1.7 - 83	18	N4494	0194	24A2BEPM-D3	1/29	70	0815	0790	0818	0816	N0817	0810	0780	0783
2.8 - 139	11	N4493	0193	24A2BEPM-D3	1/29	70	0815	0790	0818	0816	N0817	0810	0780	0783
4.2 - 208	7.1	N4492	0192	24A2BEPM-D3	1/29	70	0815	0790	0818	0816	N0817	0810	0780	0783
8.3 - 417	3.3	N4491	0191	24A2BEPM-D3	1/29	70	0815	0790	0818	0816	N0817	0810	0780	0783
0.22 - 14	100	N4563	0163	24A4BEPM-Z4	1/17	71	0815	0790	0818	0816	N0817	0810	0780	0783
0.44 - 28	92	N4562	0162	24A4BEPM-Z4	1/17	71	0815	0790	0818	0816	N0817	0810	0780	0783
0.67 - 42	40	–	0190	24A4BEPM-D3	1/17	70	0815	0790	0818	0816	N0817	0810	0780	0783
0.67 - 42	65	N4561	0161	24A4BEPM-Z3	1/17	71	0815	0790	0818	0816	N0817	0810	0780	0783
1.3 - 83	29	–	0189	24A4BEPM-D3	1/17	70	0815	0790	0818	0816	N0817	0810	0780	0783
1.3 - 83	33	N4560	0160	24A4BEPM-Z3	1/17	71	0815	0790	0818	0816	N0817	0810	0780	0783
2.2 - 139	17	–	0188	24A4BEPM-D3	1/17	70	0815	0790	0818	0816	N0817	0810	0780	0783
2.2 - 139	21	N4559	0159	24A4BEPM-Z2	1/17	71	0815	0790	0818	0816	N0817	0810	0780	0783
3.3 - 208	12	–	0187	24A4BEPM-D3	1/17	70	0815	0790	0818	0816	N0817	0810	0780	0783
3.3 - 208	14	N4558	0158	24A4BEPM-Z2	1/17	71	0815	0790	0818	0816	N0817	0810	0780	0783
6.7 - 417	5.4	–	0186	24A4BEPM-D3	1/17	70	0815	0790	0818	0816	N0817	0810	0780	0783
6.7 - 417	7	N4557	0157	24A4BEPM-Z2	1/17	71	0815	0790	0818	0816	N0817	0810	0780	0783
0.19 - 8	175	N6547	6147	33A3BEPM-W4	1/12	73	0835	0791	0838	0836	N0837	0830	0781	0784
0.35 - 15	166	N6546	6146	33A3BEPM-W4	1/12	73	0835	0790, 0791	0838	0836	N0837	0830	0780, 0781	0783, 0784
1 - 42	95	N6569	6169	33A3BEPM-Z3	1/12	72	0835	0790, 0791	0838	0836	N0837	0830	0780, 0781	0783, 0784
2 - 83	47	N6568	6168	33A3BEPM-Z3	1/12	72	0835	0790, 0791	0838	0836	N0837	0830	0780, 0781	0783, 0784
3.3 - 139	31	N6567	6167	33A3BEPM-Z2	1/12	72	0835	0790, 0791	0838	0836	N0837	0830	0780, 0781	0783, 0784
5 - 208	20	N6566	6166	33A3BEPM-Z2	1/12	72	0835	0790, 0791	0838	0836	N0837	0830	0780, 0781	0783, 0784
10 - 417	10	N6565	6165	33A3BEPM-Z2	1/12	72	0835	0790, 0791	0838	0836	N0837	0830	0780, 0781	0783, 0784
0.2 - 8.3	310	N4575	4175	42A3BEPM-E4	1/8	74	0835	0790, 0791	0838	0836	N0837	0830	0780, 0781	0783, 0784
0.33 - 14	341	N4574	4174	42A3BEPM-E4	1/8	74	0835	0790, 0791	0838	0836	N0837	0830	0780, 0781	0783, 0784
0.5 - 21	283	N4573	4173	42A3BEPM-E4	1/8	74	0835	0790, 0791	0838	0836	N0837	0830	0780, 0781	0783, 0784
0.62 - 26	155	N6556	6156	33A5BEPM-W4	1/8	73	0835	0790, 0791	0838	0836	N0837	0830	0780, 0781	0783, 0784
0.92 - 38	143	N6555	6155	33A5BEPM-W3	1/8	73	0835	0790, 0791	0838	0836	N0837	0830	0780, 0781	0783, 0784
1.4 - 57	96	N6554	6154	33A5BEPM-W3	1/8	73	0835	0790, 0791	0838	0836	N0837	0830	0780, 0781	0783, 0784
2 - 84	65	N6553	6153	33A5BEPM-W3	1/8	73	0835	0790, 0791	0838	0836	N0837	0830	0780, 0781	0783, 0784
2.9 - 123	46	N6552	6152	33A5BEPM-W2	1/8	73	0835	0790, 0791	0838	0836	N0837	0830	0780, 0781	0783, 0784
4.3 - 181	31	N6551	6151	33A5BEPM-W2	1/8	73	0835	0790, 0791	0838	0836	N0837	0830	0780, 0781	0783, 0784
6.4 - 266	21	N6550	6150	33A5BEPM-W2	1/8	73	0835	0790, 0791	0838	0836	N0837	0830	0780, 0781	0783, 0784
11 - 456	12	N6549	6149	33A5BEPM-W2	1/8	73	0835	0790, 0791	0838	0836	N0837	0830	0780, 0781	0783, 0784
16 - 660	6	N6548	6148	33A5BEPM-W2	1/8	73	0835	0790, 0791	0838	0836	N0837	0830	0780, 0781	0783, 0784
1 - 42	270	4585	4185	42A5BEPM-E3	1/4	74	0855	0791	0858	0856	N0857	0850	0781	0784
1.5 - 62	180	N4576	4184	42A5BEPM-E3	1/4	74	0855	0791	0858	0856	N0857	0850	0781	0784
2 - 83	135	4583	4183	42A5BEPM-E3	1/4	74	0855	0791	0858	0856	N0857	0850	0781	0784
3 - 125	90	N4582	4182	42A5BEPM-E3	1/4	74	0855	0791	0858	0856	N0857	0850	0781	0784
4 - 165	68	N4581	4181	42A5BEPM-E2	1/4	74	0855	0791	0858	0856	N0857	0850	0781	0784
6 - 250	45	4580	4180	42A5BEPM-E2	1/4	74	0855	0791	0858	0856	N0857	0850	0781	0784
12 - 500	25	N4579	4179	42A5BEPM-E1	1/4	74	0855	0791	0858	0856	N0857	0850	0781	0784
1.5 - 62	220	N4584	4193	42A7BEPM-F3	1/3	74	0855	0791	0858	0856	N0857	0850	0781	0784
6 - 250	72	N4578	4190	42A7BEPM-F2	1/3	74	0855	0791	0858	0856	N0857	0850	0781	0784



# Filtered DC Controls

## FPM and WPM Selection Table

### SYSTEM PERFORMANCE WHEN USING BODINE 130V PM MOTORS WITH FILTERED CONTROLS

Motor/Gearmotor Specifications							Matching Control Model Numbers								
Speed Range (rpm)	Cont. Torque (lb-in.)	Model Number		Product Type Shaft	Nameplate Rating (HP)	Ref. Page	Encased				Chassis				
		Accessory Shaft	No Accessory Shaft				Basic		Direction + Braking	Analog Signal	Digital Signal	SCR	PWM		
							SCR	PWM					Quick Connect Tabs	Term. Block	
<b>Right Angle Gearmotors</b>															
0.67 - 42	22	N4099	<b>0099</b>	24A4BEPM-3F	1/17	77	<b>0815</b>	<b>0790</b>	<b>0818</b>	<b>0816</b>	N0817	<b>0810</b>	<b>0780</b>	<b>0783</b>	
1 - 63	19	N4098	<b>0098</b>	24A4BEPM-3F	1/17	77	<b>0815</b>	<b>0790</b>	<b>0818</b>	<b>0816</b>	N0817	<b>0810</b>	<b>0780</b>	<b>0783</b>	
2 - 125	16	N4096	<b>0096</b>	24A4BEPM-3F	1/17	77	<b>0815</b>	<b>0790</b>	<b>0818</b>	<b>0816</b>	N0817	<b>0810</b>	<b>0780</b>	<b>0783</b>	
4 - 250	10	N4094	<b>0094</b>	24A4BEPM-3F	1/17	77	<b>0815</b>	<b>0790</b>	<b>0818</b>	<b>0816</b>	N0817	<b>0810</b>	<b>0780</b>	<b>0783</b>	
8 - 500	5.2	N4093	<b>0093</b>	24A4BEPM-3F	1/17	77	<b>0815</b>	<b>0790</b>	<b>0818</b>	<b>0816</b>	N0817	<b>0810</b>	<b>0780</b>	<b>0783</b>	
1.5 - 62	109	—	<b>6138</b>	33A5BEPM-5N	1/4	79	<b>0835</b>	<b>0790, 0791</b>	<b>0838</b>	<b>0836</b>	N0837	<b>0830</b>	<b>0780, 0781</b>	<b>0783, 0784</b>	
3 - 125	78	—	<b>6136</b>	33A5BEPM-5N	1/4	79	<b>0835</b>	<b>0790, 0791</b>	<b>0838</b>	<b>0836</b>	N0837	<b>0830</b>	<b>0780, 0781</b>	<b>0783, 0784</b>	
6 - 250	42	<b>6535</b>	<b>6135</b>	33A5BEPM-5N	1/4	79	<b>0835</b>	<b>0790, 0791</b>	<b>0838</b>	<b>0836</b>	N0837	<b>0830</b>	<b>0780, 0781</b>	<b>0783, 0784</b>	
12 - 500	22	—	<b>6134</b>	33A5BEPM-5N	1/4	79	<b>0835</b>	<b>0790, 0791</b>	<b>0838</b>	<b>0836</b>	N0837	<b>0830</b>	<b>0780, 0781</b>	<b>0783, 0784</b>	
0.2 - 8.6	380	N4466	<b>4066</b>	42A5BEPM-GB	1/4	85	<b>0855</b>	<b>0791</b>	<b>0858</b>	<b>0856</b>	N0857	<b>0850</b>	<b>0781</b>	<b>0784</b>	
0.3 - 13	375	N4464	<b>4064</b>	42A5BEPM-GB	1/4	85	<b>0855</b>	<b>0791</b>	<b>0858</b>	<b>0856</b>	N0857	<b>0850</b>	<b>0781</b>	<b>0784</b>	
0.5 - 21	290	N4462	<b>4062</b>	42A5BEPM-GB	1/4	85	<b>0855</b>	<b>0791</b>	<b>0858</b>	<b>0856</b>	N0857	<b>0850</b>	<b>0781</b>	<b>0784</b>	
1 - 42	213	N4460	<b>4060</b>	42A5BEPM-GB	1/4	85	<b>0855</b>	<b>0791</b>	<b>0858</b>	<b>0856</b>	N0857	<b>0850</b>	<b>0781</b>	<b>0784</b>	
1.5 - 62	79	N4538	<b>4138</b>	42A5BEPM-5N	1/4	81	<b>0855</b>	<b>0791</b>	<b>0858</b>	<b>0856</b>	N0857	<b>0850</b>	<b>0781</b>	<b>0784</b>	
2 - 83	75	N4537	<b>4137</b>	42A5BEPM-5N	1/4	81	<b>0855</b>	<b>0791</b>	<b>0858</b>	<b>0856</b>	N0857	<b>0850</b>	<b>0781</b>	<b>0784</b>	
3 - 125	75	N4536	<b>4136</b>	42A5BEPM-5N	1/4	81	<b>0855</b>	<b>0791</b>	<b>0858</b>	<b>0856</b>	N0857	<b>0850</b>	<b>0781</b>	<b>0784</b>	
6 - 250	42	<b>4535</b>	<b>4135</b>	42A5BEPM-5N	1/4	81	<b>0855</b>	<b>0791</b>	<b>0858</b>	<b>0856</b>	N0857	<b>0850</b>	<b>0781</b>	<b>0784</b>	
12 - 500	24	N4534	<b>4134</b>	42A5BEPM-5N	1/4	81	<b>0855</b>	<b>0791</b>	<b>0858</b>	<b>0856</b>	N0857	<b>0850</b>	<b>0781</b>	<b>0784</b>	
1.3 - 52	189	N4599	N4199	42A7BEPM-5H	1/3	82	<b>0855</b>	<b>0791</b>	<b>0858</b>	<b>0856</b>	N0857	<b>0850</b>	<b>0781</b>	<b>0784</b>	
1.7 - 69	151	N4598	<b>4198</b>	42A7BEPM-5H	1/3	82	<b>0855</b>	<b>0791</b>	<b>0858</b>	<b>0856</b>	N0857	<b>0850</b>	<b>0781</b>	<b>0784</b>	
3.3 - 139	87	N4596	N4196	42A7BEPM-5H	1/3	82	<b>0855</b>	<b>0791</b>	<b>0858</b>	<b>0856</b>	N0857	<b>0850</b>	<b>0781</b>	<b>0784</b>	
6 - 250	52	N4594	<b>4194</b>	42A7BEPM-5H	1/3	82	<b>0855</b>	<b>0791</b>	<b>0858</b>	<b>0856</b>	N0857	<b>0850</b>	<b>0781</b>	<b>0784</b>	
1.3 - 52	264	N4503	N4103	42A7BEPM-5H	1/2	82	—	<b>0791</b>	—	—	—	—	<b>0781</b>	<b>0784</b>	
1.7 - 69	218	N4502	<b>4102</b>	42A7BEPM-5H	1/2	82	—	<b>0791</b>	—	—	—	—	<b>0781</b>	<b>0784</b>	
3.3 - 139	129	N4501	<b>4101</b>	42A7BEPM-5H	1/2	82	—	<b>0791</b>	—	—	—	—	<b>0781</b>	<b>0784</b>	
6 - 250	71	N4500	N4100	42A7BEPM-5H	1/2	82	—	<b>0791</b>	—	—	—	—	<b>0781</b>	<b>0784</b>	

<sup>1</sup> NOTE: Model numbers shown in bold type are in stock. "N" model numbers require lead time and minimum quantities.

NOTE: Some of the newer DC motors shown in this catalog do not yet appear in these tables. Refer to [www.bodine-electric.com](http://www.bodine-electric.com) for the most up-to-date information.

New

e-TORQ™

INTEGRAMotor™

Hollow Shaft

Custom

Pacesetter™ Inverter Duty

AC Induction

Permanent Magnet DC

Brushless DC

Index

# Unfiltered DC Controls

## UPM Selection Table

### SYSTEM PERFORMANCE WHEN USING BODINE 130V PM MOTORS WITH UNFILTERED CONTROLS (90 VDC OUTPUT)

Motor/Gearmotor Specifications							Matching Chassis Control Model Numbers		
Speed Range (rpm)	Continuous Torque (lb-in.)	Model Number		Product Type	Nameplate Rating (HP)	Reference Page	Chassis		Encased
		Accessory Shaft	No Accessory Shaft				Quick Connect Tabs	Terminal Block	
<b>Motors Without Gear Reducers</b>									
50 - 1725	0.45	N4439	N0039	24A0BEPM	1/50	67	–	–	–
50 - 1725	0.80	N4441	0041	24A2BEPM	1/29	67	0865	0866	0867
40 - 1725	1.3	0047	0043	24A4BEPM	1/17	67	0865	0866	0867
60 - 1725	2.1	N6416	6016	33A3BEPM	1/12	68	0865	0866	0867
60 - 1725	3.1	N6420	6020	33A5BEPM	1/8	68	0865	0866	0867
60 - 1725	5.7	4435	4035	42A5BEPM	1/4	69	0865	0866	0867
60 - 1725	7.6	N4437	4037	42A7BEPM	1/3	69	0865	0866	0867
<b>Parallel Shaft Gearmotors</b>									
0.11 - 3.8	40	N4499	0199	24A2BEPM-D5	1/29	70	0865	0866	0867
0.17 - 5.8	40	N4498	0198	24A2BEPM-D5	1/29	70	0865	0866	0867
0.28 - 9.6	40	N4497	0197	24A2BEPM-D4	1/29	70	0865	0866	0867
0.56 - 19	40	N4496	0196	24A2BEPM-D4	1/29	70	0865	0866	0867
0.83 - 29	32	N4495	0195	24A2BEPM-D3	1/29	70	0865	0866	0867
1.7 - 58	16	N4494	0194	24A2BEPM-D3	1/29	70	0865	0866	0867
2.8 - 96	9.5	N4493	0193	24A2BEPM-D3	1/29	70	0865	0866	0867
4.2 - 144	6.4	N4492	0192	24A2BEPM-D3	1/29	70	0865	0866	0867
8.3 - 288	3.0	N4491	0191	24A2BEPM-D3	1/29	70	0865	0866	0867
0.22 - 9.6	100	N4563	0163	24A4BEPM-Z4	1/17	71	0865	0866	0867
0.44 - 19	83	N4562	0162	24A4BEPM-Z4	1/17	71	0865	0866	0867
0.67 - 29	59	N4561	0161	24A4BEPM-Z3	1/17	71	0865	0866	0867
0.67 - 29	40	–	0190	24A4BEPM-D3	1/17	70	0865	0866	0867
1.3 - 58	29	N4560	0160	24A4BEPM-Z3	1/17	71	0865	0866	0867
1.3 - 58	29	–	0189	24A4BEPM-D3	1/17	70	0865	0866	0867
2.2 - 96	19	N4559	0159	24A4BEPM-Z2	1/17	71	0865	0866	0867
2.2 - 96	17	–	0188	24A4BEPM-D3	1/17	70	0865	0866	0867
3.3 - 144	12	N4558	0158	24A4BEPM-Z2	1/17	71	0865	0866	0867
3.3 - 144	12	–	0187	24A4BEPM-D3	1/17	70	0865	0866	0867
6.7 - 288	6.3	N4557	0157	24A4BEPM-Z2	1/17	71	0865	0866	0867
6.7 - 288	5.4	–	0186	24A4BEPM-D3	1/17	70	0865	0866	0867
0.19 - 5.5	175	N6547	6147	33A3BEPM-W4	1/12	73	0865	0866	0867
0.35 - 10	166	N6546	6146	33A3BEPM-W4	1/12	73	0865	0866	0867
1 - 29	95	N6569	6169	33A3BEPM-Z3	1/12	72	0865	0866	0867
2 - 58	47	N6568	6168	33A3BEPM-Z3	1/12	72	0865	0866	0867
3.3 - 96	31	N6567	6167	33A3BEPM-Z2	1/12	72	0865	0866	0867
5 - 144	20	N6566	6166	33A3BEPM-Z2	1/12	72	0865	0866	0867
10 - 288	10	N6565	6165	33A3BEPM-Z2	1/12	72	0865	0866	0867
0.2 - 5.8	310	N4575	4175	42A3BEPM-E4	1/8	74	0865	0866	0867
0.33 - 9.6	341	N4574	4174	42A3BEPM-E4	1/8	74	0865	0866	0867
0.5 - 14	249	N4573	4173	42A3BEPM-E4	1/8	74	0865	0866	0867
0.62 - 18	155	N6556	6156	33A5BEPM-W4	1/8	73	0865	0866	0867
0.92 - 26	141	N6555	6155	33A5BEPM-W3	1/8	73	0865	0866	0867
1.4 - 39	95	N6554	6154	33A5BEPM-W3	1/8	73	0865	0866	0867
2 - 58	64	N6553	6153	33A5BEPM-W3	1/8	73	0865	0866	0867
2.9 - 84	46	N6552	6152	33A5BEPM-W2	1/8	73	0865	0866	0867
4.3 - 125	31	N6551	6151	33A5BEPM-W2	1/8	73	0865	0866	0867
6.4 - 184	21	N6550	6150	33A5BEPM-W2	1/8	73	0865	0866	0867
11 - 314	12	N6549	6149	33A5BEPM-W2	1/8	73	0865	0866	0867
16 - 454	6	N6548	6148	33A5BEPM-W2	1/8	73	0865	0866	0867
1 - 29	270	4585	4185	42A5BEPM-E3	1/4	74	0865	0866	0867
1.5 - 43	180	N4576	4184	42A5BEPM-E3	1/4	74	0865	0866	0867
2 - 58	135	4583	4183	42A5BEPM-E3	1/4	74	0865	0866	0867
3 - 86	90	N4582	4182	42A5BEPM-E3	1/4	74	0865	0866	0867
4 - 115	68	N4581	4181	42A5BEPM-E2	1/4	74	0865	0866	0867
6 - 172	45	4580	4180	42A5BEPM-E2	1/4	74	0865	0866	0867
12 - 345	25	N4579	4179	42A5BEPM-E1	1/4	74	0865	0866	0867
1.5 - 43	220	N4584	4193	42A7BEPM-F3	1/3	74	0865	0866	0867
6 - 172	65	N4578	4190	42A7BEPM-F2	1/3	74	0865	0866	0867

# Unfiltered DC Controls

## UPM Selection Table

SYSTEM PERFORMANCE WHEN USING BODINE 130V PM MOTORS WITH UNFILTERED CONTROLS (90 VDC OUTPUT)

Motor/Gearmotor Specifications							Matching Chassis Control Model Numbers		
Speed Range (rpm)	Continuous Torque (lb-in.)	Model Number		Product Type	Nameplate Rating (HP)	Reference Page	Chassis		Encased
		Accessory Shaft	No Accessory Shaft				Quick Connect Tabs	Terminal Block	
<b>Right Angle Gearmotors</b>									
.67 - 29	22	N4099	<b>0099</b>	24A4BEPM-3F	1/17	77	<b>0865</b>	<b>0866</b>	<b>0867</b>
1 - 43	19	N4098	<b>0098</b>	24A4BEPM-3F	1/17	77	<b>0865</b>	<b>0866</b>	<b>0867</b>
2 - 86	15	N4096	<b>0096</b>	24A4BEPM-3F	1/17	77	<b>0865</b>	<b>0866</b>	<b>0867</b>
4 - 172	8.6	N4094	<b>0094</b>	24A4BEPM-3F	1/17	77	<b>0865</b>	<b>0866</b>	<b>0867</b>
8 - 345	4.6	N4093	<b>0093</b>	24A4BEPM-3F	1/17	77	<b>0865</b>	<b>0866</b>	<b>0867</b>
1.5 - 43	84	—	<b>6138</b>	33A5BEPM-5N	1/8	79	<b>0865</b>	<b>0866</b>	<b>0867</b>
3 - 86	54	—	<b>6136</b>	33A5BEPM-5N	1/8	79	<b>0865</b>	<b>0866</b>	<b>0867</b>
6 - 172	31	<b>6535</b>	<b>6135</b>	33A5BEPM-5N	1/8	79	<b>0865</b>	<b>0866</b>	<b>0867</b>
12 - 345	17	—	<b>6134</b>	33A5BEPM-5N	1/8	79	<b>0865</b>	<b>0866</b>	<b>0867</b>
0.2 - 6.2	380	N4466	<b>4066</b>	42A5BEPM-GB	1/4	85	<b>0865</b>	<b>0866</b>	<b>0867</b>
0.3 - 9.1	375	N4464	<b>4064</b>	42A5BEPM-GB	1/4	85	<b>0865</b>	<b>0866</b>	<b>0867</b>
0.5 - 14	290	N4462	<b>4062</b>	42A5BEPM-GB	1/4	85	<b>0865</b>	<b>0866</b>	<b>0867</b>
1 - 29	195	N4460	<b>4060</b>	42A5BEPM-GB	1/4	85	<b>0865</b>	<b>0866</b>	<b>0867</b>
1.5 - 43	79	N4538	<b>4138</b>	42A5BEPM-5N	1/4	81	<b>0865</b>	<b>0866</b>	<b>0867</b>
2 - 58	75	N4537	<b>4137</b>	42A5BEPM-5N	1/4	81	<b>0865</b>	<b>0866</b>	<b>0867</b>
3 - 86	69	N4536	<b>4136</b>	42A5BEPM-5N	1/4	81	<b>0865</b>	<b>0866</b>	<b>0867</b>
6 - 172	40	<b>4535</b>	<b>4135</b>	42A5BEPM-5N	1/4	81	<b>0865</b>	<b>0866</b>	<b>0867</b>
12 - 345	21	N4534	<b>4134</b>	42A5BEPM-5N	1/4	81	<b>0865</b>	<b>0866</b>	<b>0867</b>
1.3 - 36	173	N4599	N4199	42A7BEPM-5H	1/3	82	<b>0865</b>	<b>0866</b>	<b>0867</b>
1.7 - 48	143	N4598	<b>4198</b>	42A7BEPM-5H	1/3	82	<b>0865</b>	<b>0866</b>	<b>0867</b>
3.3 - 96	84	N4596	N4196	42A7BEPM-5H	1/3	82	<b>0865</b>	<b>0866</b>	<b>0867</b>
6 - 172	47	N4594	<b>4194</b>	42A7BEPM-5H	1/3	82	<b>0865</b>	<b>0866</b>	<b>0867</b>
1.3 - 36	164	N4503	N4103	42A7BEPM-5H	1/2	82	<b>0865</b>	<b>0866</b>	<b>0867</b>
1.7 - 48	137	N4502	<b>4102</b>	42A7BEPM-5H	1/2	82	<b>0865</b>	<b>0866</b>	<b>0867</b>
3.3 - 96	81	N4501	<b>4101</b>	42A7BEPM-5H	1/2	82	<b>0865</b>	<b>0866</b>	<b>0867</b>
6 - 172	45	N4500	N4100	42A7BEPM-5H	1/2	82	<b>0865</b>	<b>0866</b>	<b>0867</b>

<sup>1</sup> NOTE: Model numbers shown in bold type are in stock. "N" model numbers require lead time and minimum quantities.

NOTE: Some of the newer DC motors shown in this catalog do not yet appear in these tables. Refer to [www.bodine-electric.com](http://www.bodine-electric.com) for the most up-to-date information.

# Accessories

## For Permanent Magnet Motors and Controls

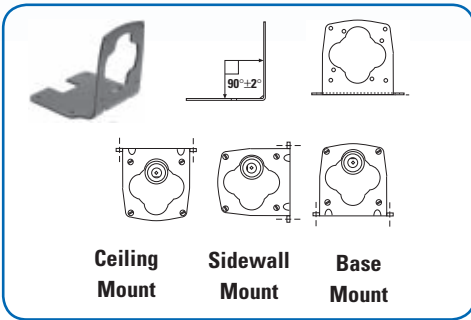

### Motor and Gearmotor "L" Brackets

Model No.	Description	lbs.	Dimensions	Deflection lbs.
0969	Kit for "E" and "F" gearmotors	2.5	Page 74	200
0970	Kit for "W" gearmotors	1.75	Page 73	125
0990	Kit for 24A motors	1	Page 67	25
5968	Kit for 33A motors and 24A-D, 24A-Z, 33A-Z gearmotors	1.25	Page 68 70, 71, 72	50

Parallel shaft, stock gearmotors are designed for universal horizontal mounting only. See "Mounting Positions" on page 2.

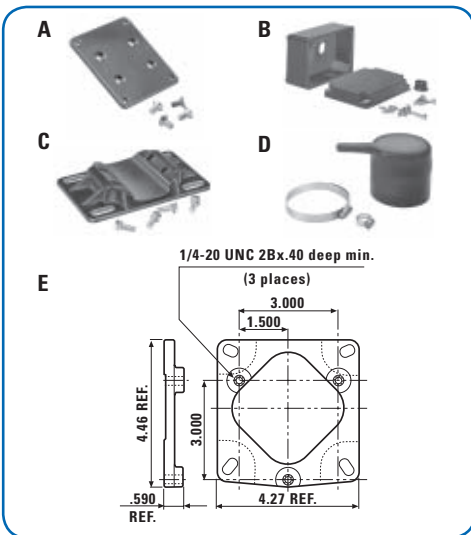

### Other Motor and Gearmotor Kits

Item	Model No.	Description	lbs.	Dimensions
A	0967	Base mounting kit for 3F gearmotors	.5	Page 77
B	0984	Die cast terminal box kit for 33A, and 42A motors and gearmotors	1	Page 50
B	1984	Die cast terminal box kit with terminal block for 33A and 42A motors and gearmotors		Page 50
C	0991	Die cast base kit for 42A motors	.33	Page 69
D	0978	IP-44 kit for 42A		-
E	0995	Adaptor plate kit for E, F and W gearheads provides drop-in replacement of competitive gearmotors.	.5	At left

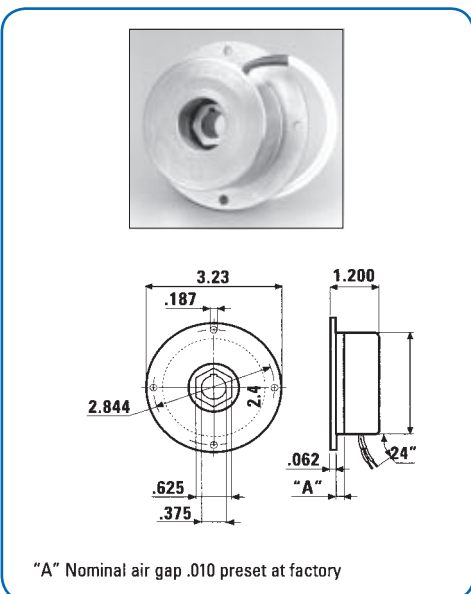

### DC Motor and Gearmotor Brake Kit

Model No.	Static Torque (lb-in.)	Volt AC	Ohms	Weight (oz.)
0997	17.7	115	1067	11

- Spring applied brake
- Hex drive with anti-rattle feature
- Kit includes mounting hardware
- Kit fits 33A and 42A permanent magnet motors and gearmotors only

# Accessories

## For Permanent Magnet Motors and Controls

New

e-TORQ™

INTEGRATOR™

Hollow Shaft

Custom

Pacesetter™ Inverter Duty

AC Induction

Permanent Magnet DC

Brushless DC

Index

### Items for Type FPM Controls

Item	Model No.	Accessory Description
	<b>0888</b>	Analog Interface Board for use with Control Models 0810, 0830, and 0850. Allows control to accept a variable voltage or current signal from user's host controller in order to automatically control motor speed. Inputs are optically isolated.
	<b>0889</b>	Digital Interface Board for use with Control Models 0810, 0830, and 0850. Allows control to accept 8 parallel TTL signals from user's host controller in order to automatically control motor speed. Inputs are optically isolated.
A	<b>0890</b>	Electronic Direction & Braking Board for use with Control Models 0810, 0830, and 0850. Allows user to change motor direction and to dynamically brake motor to a quick stop. Inputs are not optically isolated.
B	<b>0893</b>	Local/Remote Switch for use with Control Models 0810, 0830, and 0850 when used with Accessory Models 0888 and 0889. Allows user to switch between automatic and manual operation.
	<b>0895</b>	Sealing Kit for use with any type FPM encased control in order to upgrade standard NEMA 12 enclosure for IP-44 rating
C	<b>3984</b>	Analog interface and isolation module model 3984 provides Analog interface and isolates controls from system controller input signals which may be at different potentials.

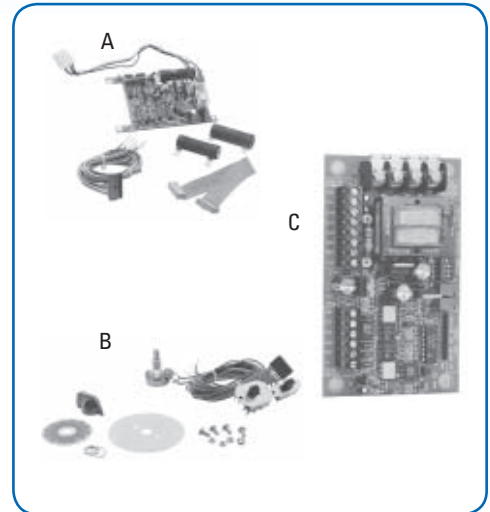

### Encoder Kits

Model Number	Renco Number	Resolution (Pulses per Revolution)	Fits Permanent Magnet Bodine Types
<b>0940</b>	RM15D-360-1/4-G6-5CA24-LD-1-C4	360	24A,
<b>0941</b>	RM15D-360-3/8-G6-5CA24-LD-1-H4	360	33A, 42A

- Kits are designed for quick and easy installation to accessory ready models.
- Incremental encoder output may be used for speed verification or readout.
- 5 VDC, 135 mA input, TTL/CMOS compatible, 20 mA sink output
- Quadrature, 2 channel output, with 1 index pulse per revolution
- Encoder cable is 24 inches long, terminated with AMP 103650-7 connector.
- 1.50 inches in diameter, 0.82 inches long



### Motor Mounting Holes for Accessories

(See detail "F" on dimension drawings)

**24A frame Accessory Ready Models**  
No adaptor plate required for mounting encoder model 0940.

**33A and 42A frames Accessory Ready Models**  
No adaptor plate required for mounting encoder model 0940 or brake model 0977.

Above drawings show accessory mounting holes reflected on motor dimension drawings. See "F".

### Brake, Encoder, And Tachometer (B.e.t.) Ready Models

Model 0992 adaptor plate is designed to attach accessories requiring a mounting bolt pattern or machining other than that provided on motors and gearmotors with accessory ready shaft extensions. These plates may be modified with either a lathe or drill press. IP-44 protection is maintained when using this adaptor plate. It is not necessary to disassemble the motor or gearmotor.

# Custom Solution: Low Voltage PWM BLDC Control

Chassis, Speed and Direction Control

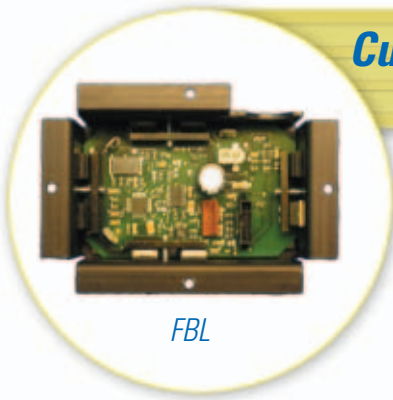

FBL



### Standard Features

- 24 Volt power requirement makes this control ideal for portable, battery-powered applications or applications where safety standards dictate a low operating voltage
- Compact size allows installation in cramped quarters
- Accepts remote digital PWM signal for speed control
- Accepts high/low input for direction
- Built-in shunt regulator for handling regenerative energy during dynamic braking
- Heat sink provides protection against people and large objects when installed with the open side against the mounting surface
- 1/4" QC tabs for power connections and plug-in connectors for logic connections
- Contact your Bodine **MotionPro** sales representative or authorized distributor with application information or for technical questions (minimum annual quantities apply)

### Preliminary Specifications:

HP Rating	Input Voltage (VDC)	Output Voltage (VDC)	Continuous Output Current (Amps)	Peak Output Current (Amps)	Product Type
1/10	24	0 - 24	5.0	7.5	FBL-6009C

### Dimensions

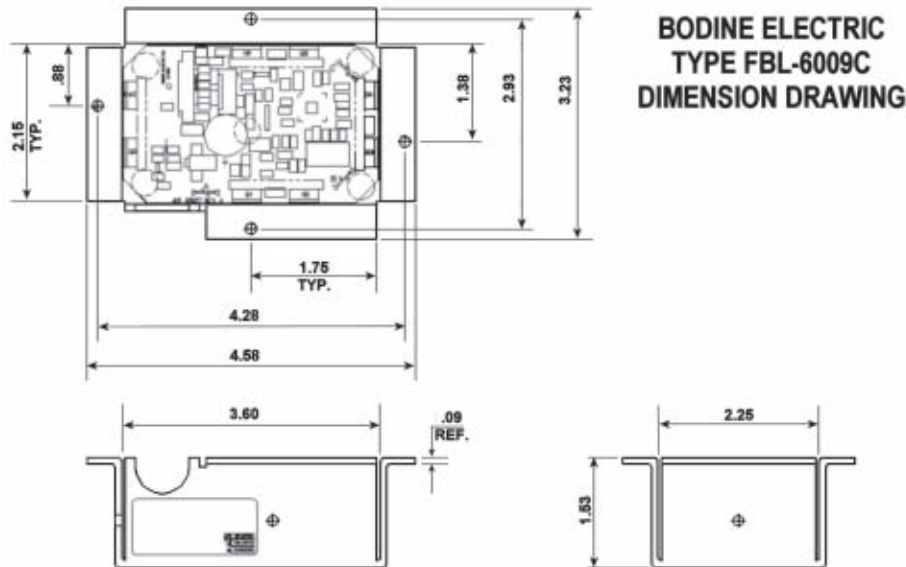



# Brushless DC Products

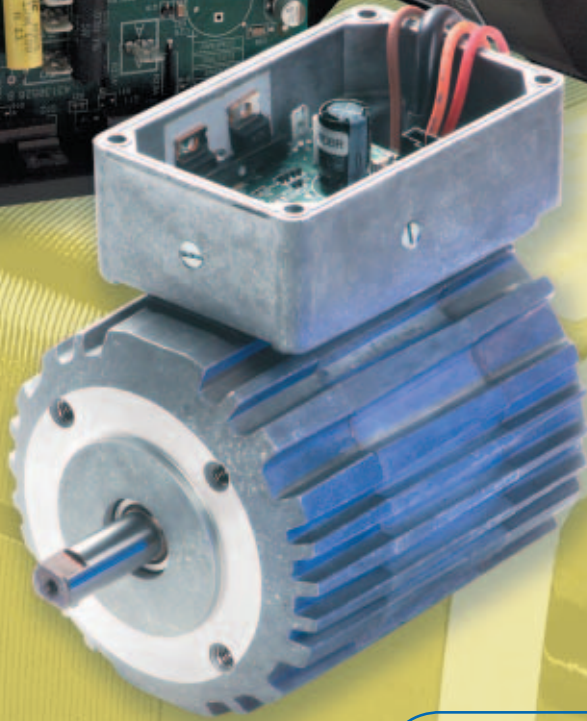
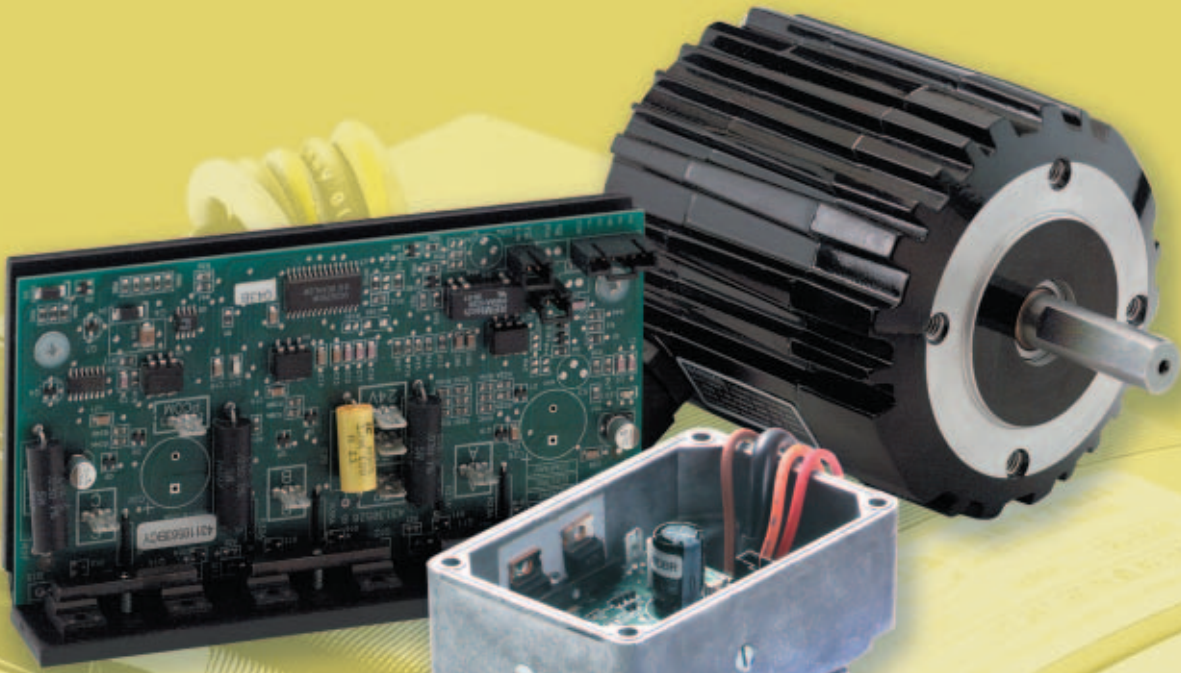

- **Ideal for continuous duty applications**
- **Better performance than permanent magnet DC systems. No brushes to replace.**
- **Low-voltage 24V models available.**
- **Over 50 Integramotor models in this issue.**
- **Proven system solutions. High-speed designs available.**
- **Economical alternative to stepper and servo systems.**

# Brushless DC Motors

## Technical Information

### Brushless Motor Construction

Because most people who work with motors are familiar with brush-type permanent magnet (PM) motors, it is helpful to explain the construction of a brushless DC (BLDC) motor by comparing it to the PM motor. BLDC motors are sometimes referred to as “inside-out PM motors” because their speed-torque curves are very similar to those of PM motors. However, BLDC motors have their magnets on the rotating part of the motor instead of on the stationary part. Accordingly, they have their windings on the stationary part of the motor instead of on the rotating part, as in a PM motor. **Figure 1** shows the construction differences between the BLDC and the PM motors.

The other major construction difference is the means for switching winding phases on and off, as shown in **Figure 2**. A PM motor uses brushes that press against a commutator attached to the armature. As the armature turns, the brushes come into contact with different segments of the commutator and change the current path through the winding. The interaction between the magnetic field created in the armature and the permanent magnet field in the stationary part of the motor results in rotation of the armature. Operation of a BLDC motor is similar

except that the winding phases are switched on and off electronically by means of a control device. The control “knows” when to switch the windings because of feedback it receives from rotor position Hall effect sensors.

### Benefits of Brushless

- Having the winding, which is the heat-generating part of the motor, closer to the outside surface of the motor results in a motor that dissipates heat well and that can therefore handle higher continuous loads without exceeding its temperature limit.
- Having no brushes results in a motor that requires less maintenance and that has a longer life because there are no brushes or commutator to wear out.
- The absence of brushes also results in a motor that is quieter because there is no sliding friction to create audible noise and no current arcing across an air gap to create electrical noise.
- There is also no brush dust generated by a brushless motor, so they won't contaminate a clean room environment.
- The lower inertia of a brushless rotor, compared to a wound armature, results in a motor that can accelerate and decelerate quickly.

### Typical Applications

Brushless DC motors are well-suited for applications that require very high speeds, where a brush-type motor would generate a loud noise and wear out brushes very quickly. Examples include centrifuges, grinders, and fans.

Because brushless DC motor speed controls rely on Hall sensor feedback for speed regulation instead of back-EMF, there is only minimal speed drift as the motor warms up. This is beneficial in applications where the speed can't deviate from its setting from the time the machine is turned on until the time it is turned off. Examples include film processors, commercial food ovens, and medical pumps.

The low inertia of the brushless DC motor, coupled with the high peak torque capacity, result in a motor capable of quick accelerations and decelerations. This makes them an excellent choice in “servo” type applications where quick and precise positioning is needed. Examples include screen printing machinery, material handling equipment, and office machinery.

**Figure 1:** Basic Motor Construction

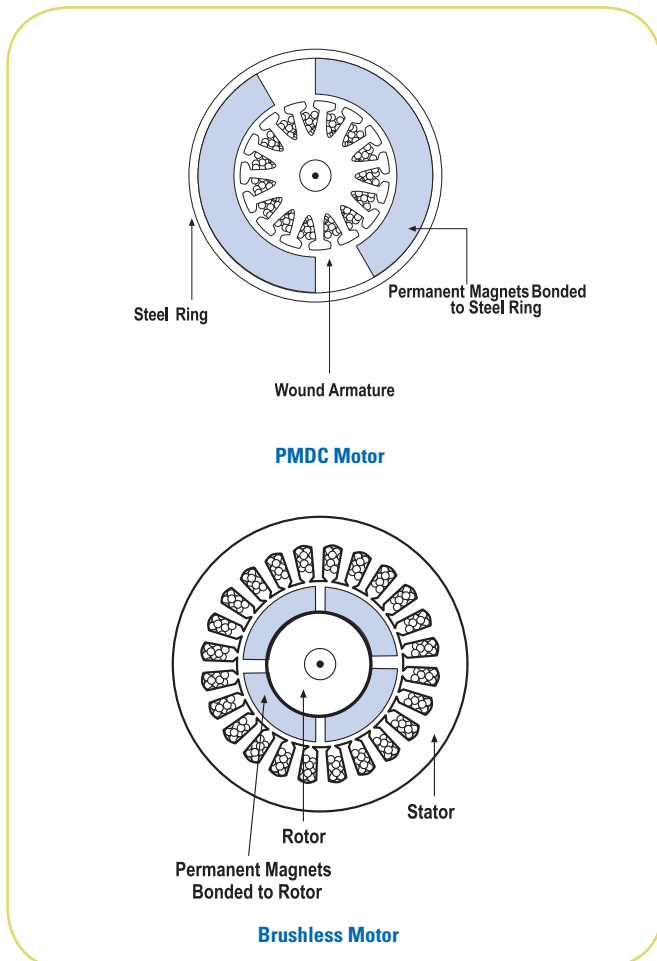

**Figure 2:** Commutation Methods

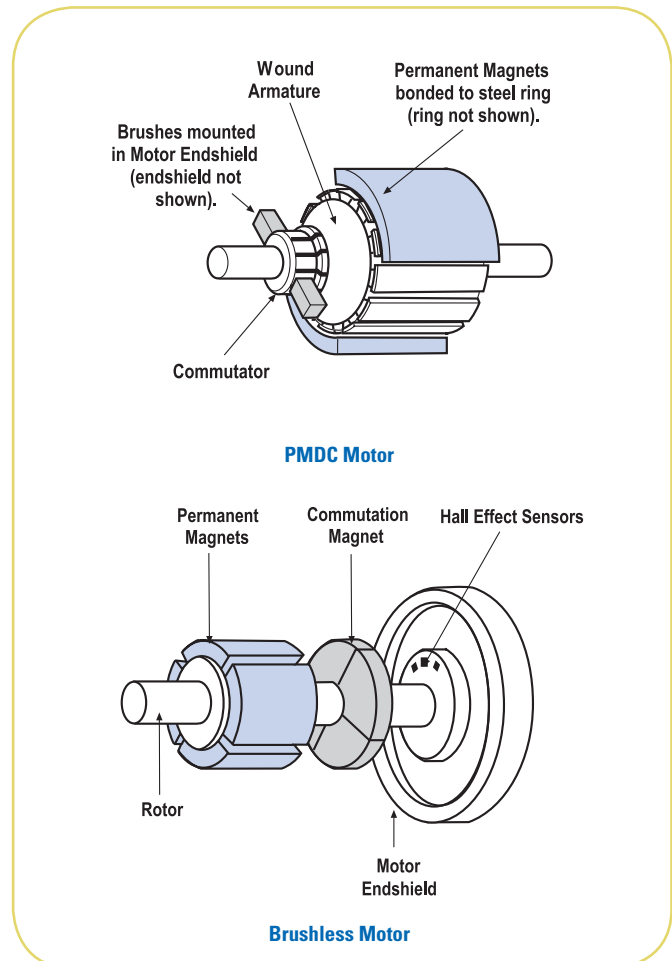

# Brushless DC Motors

## Electrical Connections

### Wiring Harness for 24 Volt Motors and Gearmotors

Bodine 24 Volt motors and gearmotors have four 18 AWG wires and a five-conductor shielded cable for connection to a Bodine 24 Volt control. The three motor phase connections are made with .250" quick connect

receptacles. The ground lead is terminated with a ring terminal and the 24 AWG commutation leads inside the 5-conductor shielded cable are terminated in a 6-pin in-line connector with 0.1" center distances.

The harness is a nominal 24" long from the motor housing to the end of the connections.

Pin Location	Wire Color & Size	Pin Part No.	Connector Part No.	Function
-	Red, 18 AWG	-	AMP 640902-1	Phase B
-	Brown, 18 AWG	-	AMP 640902-1	Phase A
-	Orange, 18 AWG	-	AMP 640902-1	Phase C
-	Green/Yellow, 18 AWG	-	AMP 640204-1	Earth /Ground Shield Drain
1	Drain Wire	MOLEX 08-50-0113	MOLEX 22-01-3067	Sensor Common
2	Black, 24 AWG	MOLEX 08-50-0113		Hall C
3	Green, 24 AWG	MOLEX 08-50-0113		Hall B
4	White, 24 AWG	MOLEX 08-50-0113		Hall A
5	Brown, 24 AWG	MOLEX 08-50-0113		Sensor Power
6	Red, 24 AWG	MOLEX 08-50-0113		

### Wiring Harness for 24 Volt Motors and Gearmotors (34B shown)

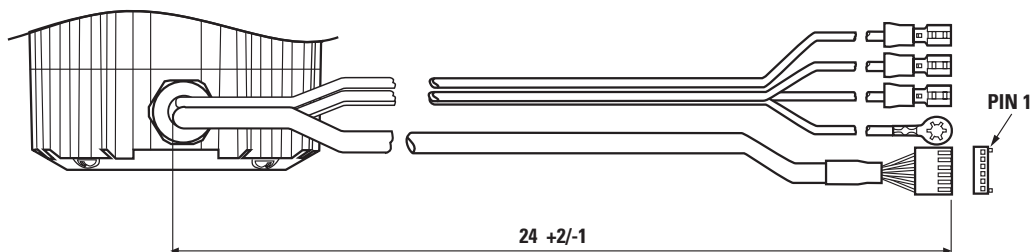

### Wiring Harness for 130 Volt Motors and Gearmotors

Bodine 130 Volt motors and gearmotors have a single 14-pin plug & twist connector at the end of a nominal 12" long harness. This provides a quick and easy means of connecting the motor or gearmotor to a Bodine 115 VAC control. An interface cable is

needed between the motor and the control. This cable may be supplied by the customer or it can be purchased from Bodine Electric. Model 3983 is a 6' long cable that can be used to connect 130 Volt motors and gearmotors to Bodine control models

3910, 3911, and 3921. Model 3982 is a 6' long cable that can be used to connect 130 Volt motors and gearmotors to Bodine control model 3912. It can also be used as an extension cable for use with any of the above mentioned controls. Encased model 3912 includes a 6' cable.

Pin Location	Wire Color & Size	Pin Part No.	Connector Part No.	Function
2	Red, 18 AWG	AMP 66098-7	AMP 206044-1	Phase B
1	Brown, 18 AWG	AMP 66098-7		Phase A
3	Orange, 18 AWG	AMP 66098-7		Phase C
4	Green/Yellow, 18 AWG	AMP 66098-7		Earth Ground Shield Drain
11	Drain Wire	AMP 66102-7		Sensor Common
10	Black, 24 AWG	AMP 66102-7		Hall C
14	Green, 24 AWG	AMP 66102-7		Hall B
13	White, 24 AWG	AMP 66102-7		Hall A
12	Brown, 24 AWG	AMP 66102-7		Sensor Power
9	Red, 24 AWG	AMP 66102-7		

### Wiring Harness for 130 Volt Motors and Gearmotors (34B shown)

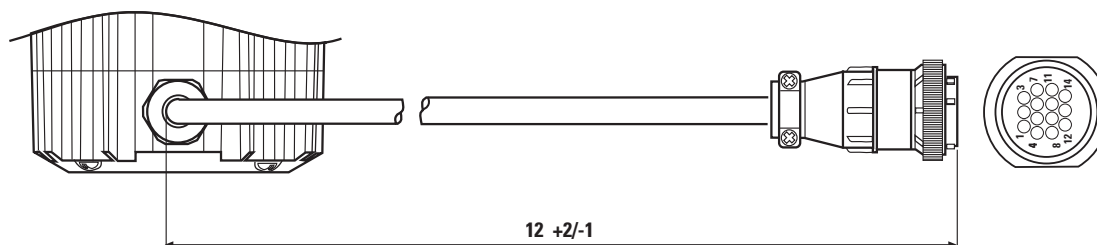

# Brushless DC Motors

1/16 - 1/5 HP

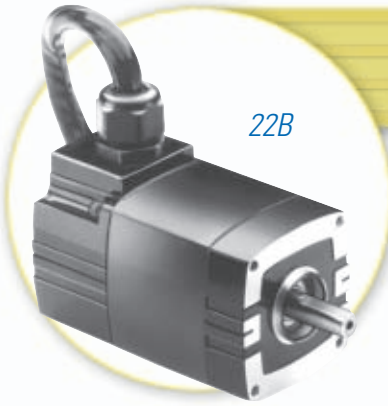

22B

FOR MODELS WITH  
BUILT-IN CONTROLS

**INTEGRAmotor™**

SEE PAGES 7-10

### Standard Features

- Totally Enclosed, Non-Ventilated
- IP-44, 130V models only
- Plug-in connectors facilitate electrical connections
- Electronic commutation provides quiet operation and low electro-magnetic interference (EMI) while eliminating brush maintenance and contamination from brush dust
- Molded hall sensor assembly for accurate commutation
- Wound stator with exposed laminations provides excellent heat transfer and allows maximum power per motor frame size
- Rare earth magnets on the rotor provide high torque and low rotor inertia

### Application Information

- Brushless motors require a control
- Electrical connections shown on page 105
- Performance ratings based on 115° C winding, 25° C ambient, and no heat sink
- May have to be operated below ratings if unfiltered control is used and if duty is continuous (see page

121 for specific unfiltered ratings)

- May be operated above ratings if duty is intermittent and/or if heat sink is provided (consult a Bodine applications engineer first)
- Face mounting is standard

### Optional Accessories

- 360 pulse/revolution optical encoder model 0940, see page 122 (requires adaptor plate model 0993 also)
- Cable model 3983 for connecting 130V motors to Bodine chassis controls, see page 122
- Adaptor model 0993 for mounting encoder, see page 122

### Matching Controls

- Motors may be used with a variety of controls, including servo amplifiers, that produce square-wave current for 3-phase, 4-pole brushless motors with 60° commutation
- Bodine stocks a full line of single-quadrant speed controls ideally matched for Bodine's brushless motors, see pages 114-121

Speed (rpm)	Rated Torque (oz-in.)	Motor HP	Torque Constant (oz-in./A)	Voltage Constant (V/krpm)	Winding Res. (ohms)	Winding Induct. (mH)	Rotor Inertia (oz-in.-sec. <sup>2</sup> )	Radial Load (lbs.)	Length XH (inch)	Wt. (lbs.)	Product Type	Model Number <sup>1</sup>			
												24 Volt Winding		130 Volt Winding	
												Acc'y. Shaft	No Acc'y. Shaft	Acc'y. Shaft	No Acc'y. Shaft
2500	25	1/16	8.4	5.8	1.2	2.1	.0036	25	3.67	2.5	22B2BEBL	N3602	<b>3502</b>	-	-
2500	25	1/16	47	35	40	70	.0036	25	3.67	2.5	22B2BEBL	-	-	-	<b>3302</b>
2500	50	1/8	9.0	6.7	.52	1.1	.0072	25	4.63	3.5	22B4BEBL	<b>3604</b>	N3504	-	-
2500	50	1/8	50	37	15	40	.0072	25	4.63	3.5	22B4BEBL	-	-	<b>3404</b>	<b>3304</b>
10,000	20	1/5	14	9.8	4.8	10	.0072	25	4.63	3.5	22B4BEBL	-	-	-	<b>3314</b>

<sup>1</sup> NOTE: Model numbers shown in bold type are in stock. "N" model numbers require lead time and minimum quantities.

**22B Motor** 130V design shown with optional "accessory ready" mounting holes

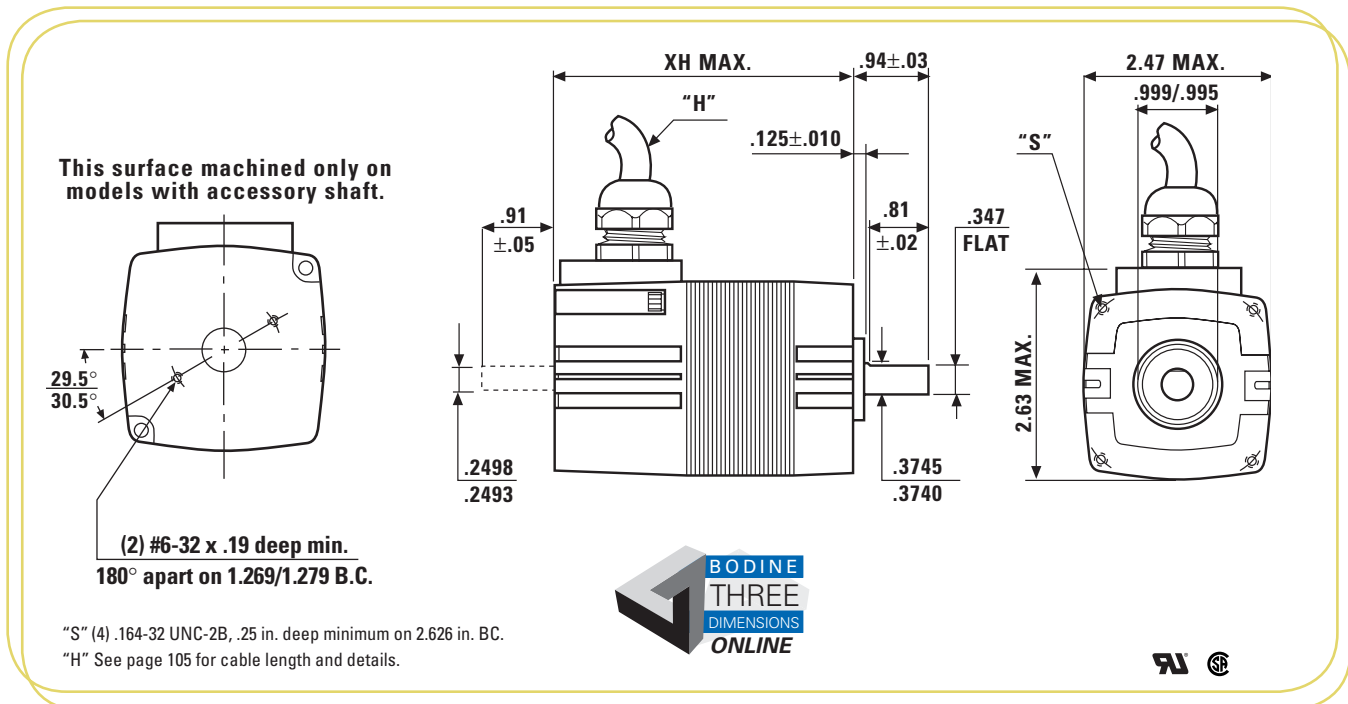

# Brushless DC Motors

1/5 - 3/8 HP

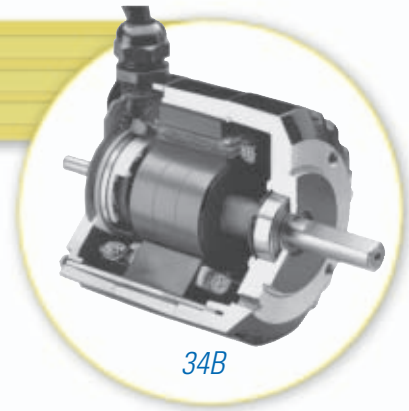

34B

New

e-TORQ™

INTEGRATOR™

Hollow Shaft

Custom

Pacesetter™ Inverter Duty

AC Induction

Permanent Magnet DC

Brushless DC

Index

## Standard Features

- Totally Enclosed, Non-Ventilated (IP-44)
- Plug-in connectors facilitate electrical connections
- Electronic commutation provides quiet operation and low electromagnetic interference (EMI) while eliminating brush maintenance and contamination from brush dust
- Molded hall sensor assembly for accurate commutation
- Wound stator with integrally cast cooling fins provides excellent heat transfer and allows maximum power per motor frame size
- Rare earth magnets on the rotor provide high torque and low rotor inertia

- 121 for specific unfiltered ratings)
- May be operated above ratings if duty is intermittent and/or if heat sink is provided (consult a Bodine applications engineer first)
- Face mounting is standard

## Optional Accessories

- 360 pulse/revolution optical encoder model 0940, see page 122
- Cable model 3983 for connecting 130V motors to Bodine chassis controls, see page 122
- "L" bracket kit model 0979 permits base, ceiling, and sidewall mounting, see page 122

## Matching Controls

- Motors may be used with a variety of controls, including servo amplifiers, that produce square-wave current for 3-phase, 4-pole brushless motors with 60° commutation
- Bodine stocks a full line of single-quadrant speed controls ideally matched for Bodine's brushless motors, see pages 114-121

## Application Information

- Brushless motors require a control
- Electrical connections shown on page 105
- Performance ratings based on 115° C winding, 25° C ambient, and no heat sink
- May have to be operated below ratings if unfiltered control is used and if duty is continuous (see page

Speed (rpm)	Rated Torque (oz-in.)	Motor HP	Torque Constant (oz-in./A)	Voltage Constant (V/krpm)	Winding Res. (ohms)	Winding Induct. (mH)	Rotor Inertia (oz-in.-sec. <sup>2</sup> )	Radial Load (lbs.)	Length XH (inch)	Wt. (lbs.)	Product Type	Model Number <sup>1</sup>			
												24 Volt Winding		130 Volt Winding	
												Acc'y. Shaft	No Acc'y. Shaft	Acc'y. Shaft	No Acc'y. Shaft
2500	81	1/5	8.8	6.6	.3	.54	.0115	42	4.06	6.0	34B3BEBL	<b>3600</b>	<b>3500</b>	-	-
2500	81	1/5	51	38	9.2	24	.0115	42	4.06	6.0	34B3BEBL	-	-	<b>3406</b>	<b>3306</b>
2500	101	1/4	9.0	6.7	.17	.40	.0154	42	4.56	7.0	34B4BEBL	-	N3507	-	-
2500	101	1/4	51	38	5.8	14	.0154	42	4.56	7.0	34B4BEBL	-	-	-	<b>3307</b>
2500	151	3/8	9.0	6.7	.087	.246	.0215	42	5.56	9.0	34B6BEBL	N3609	N3509	-	-
2500	151	3/8	57	42	3.4	11	.0215	42	5.56	9.0	34B6BEBL	-	-	<b>3409</b>	<b>3309</b>
10,000	33	1/3	14.5	10.7	1.7	4.6	.0154	42	4.56	7.0	34B4BEBL	-	-	-	<b>3317</b>

<sup>1</sup> NOTE: Model numbers shown in bold type are in stock. "N" model numbers require lead time and minimum quantities.

**34B Motor** shown with optional "L" bracket (model 0979) and optional "accessory ready" mounting holes

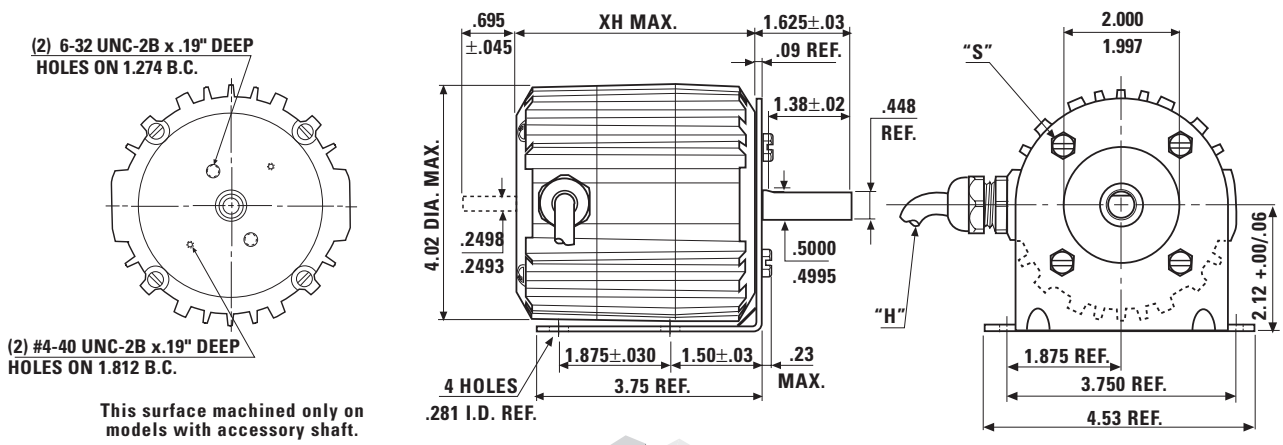

"S" (4) .250-20 UNC-2B, .31 in. deep minimum on 2.750 in. BC.  
 "H" See page 105 for cable length and details.



# Parallel Shaft BLDC Gearmotors

Up to 40 lb-in. continuous

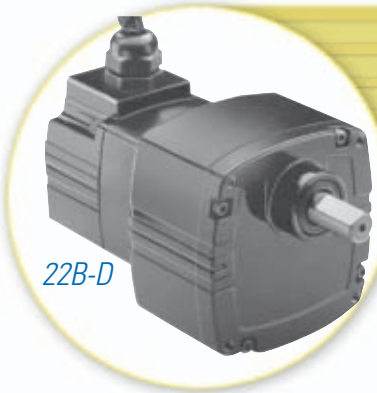

22B-D

FOR MODELS WITH  
BUILT-IN CONTROLS

**INTEGRAmotor™**

SEE PAGES 7-10

### Standard Features

- Brushless motor for higher torque, smaller size and no maintenance, see page 106
- Industrial lip type seals on motor and output shafts
- Needle bearings on output shaft for increased radial load capacity and long life
- Permanently lubricated with high-performance lubricant
- Reinforced thermoplastic helical gear on input stage for quietness and hardened steel spur gears on subsequent stages for high output torque and long life
- Helical pinion accurately cut on motor shaft for maximum strength and minimum noise

### Application Information

- Brushless motors require a control.
- Electrical connections shown on page 105
- Performance ratings based on 115° C winding, 25° C ambient, and no heat sink
- Face mounting is standard

### Optional Accessories

- Encoder model 0940, see page 122 (requires adaptor plate model 0993 also)
- Cable model 3983 for connection to chassis controls, see page 122
- Adaptor model 0993 for encoders, see page 122
- "L" bracket kit model 5968 permits alternate mounting, see page 122

### Matching Controls

- Bodine stocks a full line of speed controls for Bodine's brushless motors, see pages 114-121

		Current @ Rated Torque (Amps)						Model Number <sup>1</sup>						
Speed (rpm)	Rated Torque (lb-in.)	24 Volt Winding	130 Volt Winding	Peak Torque (lb-in.)	Motor HP	Gear Ratio	Radial Load (lbs.)	Length, XH (inch)	Weight (lbs.)	Product Type	24 Volt Winding		130 Volt Winding	
											Accessory Shaft	No Accessory Shaft	Accessory Shaft	No Accessory Shaft
14	40	3.3	.53	55	1/16	180	60	5.58	3.75	22B2BEBL-D4	N3636	N3536	N3433	<b>3333</b>
28	40	3.3	.53	55	1/16	90	60	5.58	3.75	22B2BEBL-D4	N3635	N3535	N3431	N3331
42	40	3.3	.53	55	1/16	60	60	5.58	3.75	22B2BEBL-D3	N3634	N3534	N3430	N3330
83	29	3.3	.53	33	1/16	30	60	5.58	3.75	22B2BEBL-D3	<b>3629</b>	N3529	N3429	<b>3329</b>
139	17	3.3	.53	20	1/16	18	60	5.58	3.75	22B2BEBL-D3	N3628	N3528	N3428	N3328
208	12	3.3	.53	13	1/16	12	60	5.58	3.75	22B2BEBL-D3	N3627	N3527	N3427	<b>3327</b>
417	5.8	3.3	.53	6.2	1/16	6	60	5.58	3.75	22B2BEBL-D3	N3626	N3526	N3426	<b>3326</b>

<sup>1</sup> NOTE: Model numbers shown in bold type are in stock. "N" model numbers require lead time and minimum quantities.

**22B-D Gearmotor** 130V design shown with optional "L" bracket (model 5968) and optional "accessory ready" mounting holes

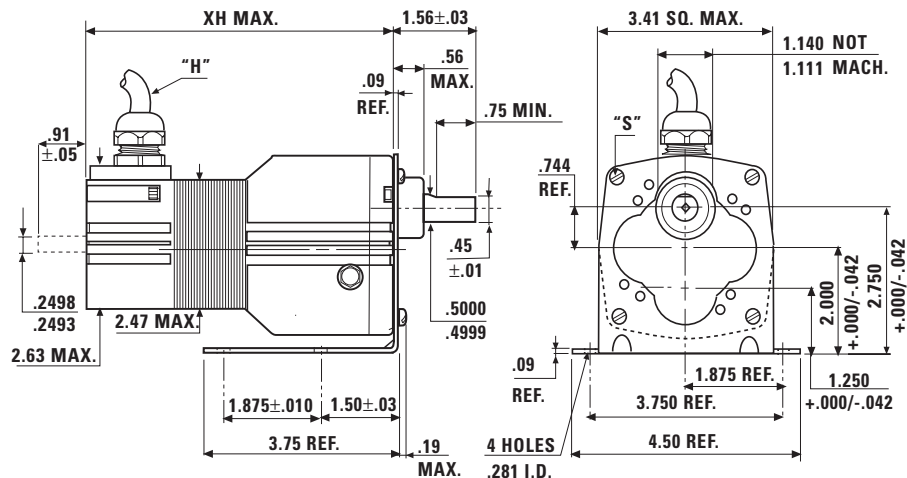
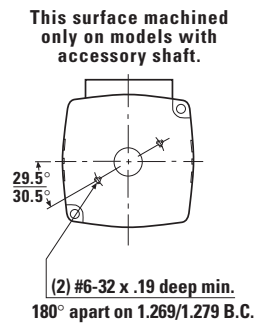

"S" (4) 10-32, UNF-2B, .38 in. minimum on a 3.75 in. B.C.  
"H" See page 105 for cable length and details.



# Parallel Shaft BLDC Gearmotors

Up to 100 lb-in. continuous

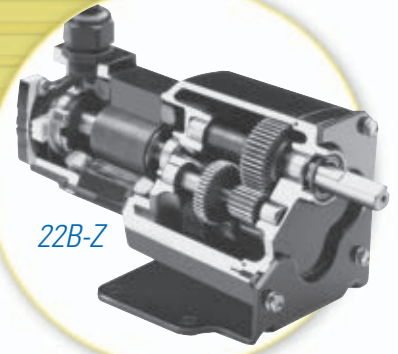

22B-Z

FOR MODELS WITH  
BUILT-IN CONTROLS

**INTEGRAmotor™**

SEE PAGES 7-10

## Standard Features

- Brushless motor for higher torque, smaller size and no maintenance, see page 106
- Industrial lip type seals on motor and output shafts
- Needle bearings on output shaft for increased radial load capacity and long life
- Permanently lubricated with high-performance lubricant
- Wide reinforced thermoplastic helical gear on input stage for quietness and wide hardened steel spur gears on subsequent stages for high output torque and long life
- Helical pinion accurately cut on motor shaft for maximum strength and minimum noise

- Performance ratings based on 115° C winding, 25° C ambient, and no heat sink
- Face mounting is standard

## Optional Accessories

- Encoder model 0940, see page 122 (requires adaptor plate model 0993 also)
- Cable model 3983 for connection to chassis controls, see page 122
- Adaptor model 0993 for encoders, see page 122
- "L" bracket kit model 5968 permits alternate mounting, see page 122

## Matching Controls

- Bodine stocks a full line of speed controls for Bodine's brushless motors, see pages 114-121

## Application Information

- Brushless motors require a control
- Electrical connections shown on page 105

Speed (rpm)	Rated Torque (lb-in.)	Current @ Rated Torque (Amps)		Peak Torque (lb-in.)	Motor HP	Gear Ratio	Radial Load (lbs.)	Length, XH (inch)	Weight (lbs.)	Product Type	Model Number <sup>1</sup>			
		24 Volt Winding	130 Volt Winding								24 Volt Winding	130 Volt Winding		
											Accessory Shaft	No Accessory Shaft	Accessory Shaft	No Accessory Shaft
14	100	—	.76	115	1/11	180	110	7.29	5.25	22B3BEBL-Z4	—	—	N3463	<b>3363</b>
14	100	3.3	.53	115	1/16	180	110	6.81	4.75	22B2BEBL-Z4	—	N3563	—	—
21	100	3.3	.53	115	1/16	120	110	6.81	4.75	22B2BEBL-Z4	—	N3564	—	N3364
28	100	4.4	.76	115	1/11	90	110	7.29	5.25	22B3BEBL-Z4	—	—	N3462	N3362
28	97	3.3	.53	115	1/16	90	110	6.81	4.75	22B2BEBL-Z4	—	N3562	—	—
42	95	4.4	.76	115	1/11	60	110	7.29	5.25	22B3BEBL-Z3	<b>3661</b>	N3561	N3461	N3361
83	52	4.4	.76	59	1/11	30	125	7.29	5.25	22B3BEBL-Z3	N3660	N3560	N3460	N3360
139	31	4.4	.76	38	1/11	18	125	6.39	5.25	22B3BEBL-Z2	N3659	N3559	N3459	N3359
208	20	4.4	.76	25	1/11	12	120	6.39	5.25	22B3BEBL-Z2	N3658	N3558	N3458	<b>3358</b>
417	10	4.4	.76	13	1/11	6	100	6.39	5.25	22B3BEBL-Z2	N3657	N3557	N3457	<b>3357</b>

<sup>1</sup> NOTE: Model numbers shown in bold type are in stock. "N" model numbers require lead time and minimum quantities.

**22B-Z Gearmotor** 130V design shown with optional "L" bracket (model 5968) and optional "accessory ready" mounting holes

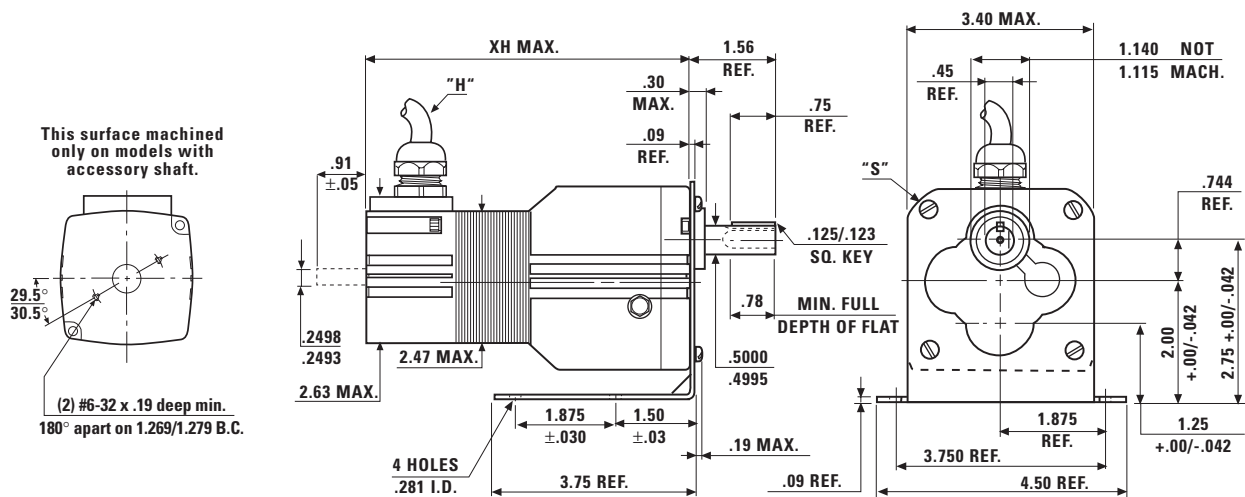

# Parallel Shaft BLDC Gearmotors

Up to 200 lb-in. continuous

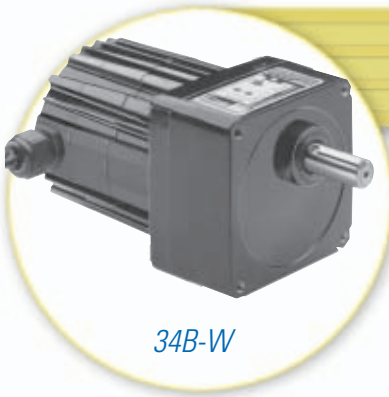

34B-W

### Standard Features

- Brushless motor for higher torque, smaller size and no maintenance, see page 107
- Industrial lip type seals on motor and output shafts
- Needle bearings on output shaft for increased radial load capacity and long life
- Permanently lubricated with high-performance lubricant
- Nylon helical gear on input stage for quietness and hardened steel spur gears on subsequent stages for high output torque and long life
- Helical pinion accurately cut on motor shaft for maximum strength and minimum noise

- Performance ratings based on 115° C winding, 25° C ambient, and no heat sink
- Face mounting is standard

### Optional Accessories

- Encoder model 0940, see page 122
- Cable model 3983 for connection to chassis controls, see page 122
- L-Bracket kit model 0970 permits alternate mounting, see page 122
- Adaptor plate kit model 0995 provides for drop-in replacement of competitive gearmotors, see page 122

### Application Information

- Brushless motors require a control
- Electrical connections shown on page 105

### Matching Controls

- Bodine stocks a full line of speed controls for Bodine's brushless motors, see pages 114-121

		Current @ Rated Torque (Amps)										Model Number <sup>1</sup>			
												24 Volt Winding		130 Volt Winding	
Speed (rpm)	Rated Torque (lb-in.)	24 Volt Winding	130 Volt Winding	Peak Torque (lb-in.)	Motor HP	Gear Ratio	Radial Load (lbs.)	Length, XH (inch)	Weight (lbs.)	Product Type	Accessory Shaft	No Accessory Shaft	Accessory Shaft	No Accessory Shaft	
8	175	9.6	1.6	210	1/5	312.4	130	6.54	9.0	34B3BEBL-W4	N3647	N3547	N3447	N3347	
14	166	9.6	1.6	207	1/5	172.1	130	6.54	9.0	34B3BEBL-W4	N3624	N3524	N3446	<b>3346</b>	
26	154	9.6	1.6	190	1/5	97.5	140	6.54	9.0	34B3BEBL-W4	N3656	N3556	N3456	N3356	
38	143	9.6	1.6	157	1/5	65.5	140	6.54	9.0	34B3BEBL-W3	N3617	N3517	N3455	N3355	
84	65	9.6	1.6	71	1/5	29.7	160	6.54	9.0	34B3BEBL-W3	N3653	N3553	N3453	<b>3353</b>	
122	46	9.6	1.6	52	1/5	20.4	60	6.54	9.0	34B3BEBL-W2	N3652	N3552	N3452	<b>3352</b>	
266	21	9.6	1.6	24	1/5	9.4	80	6.54	9.0	34B3BEBL-W2	N3623	N3523	N3450	N3350	
456	12	9.6	1.6	14	1/5	5.5	90	6.54	9.0	34B3BEBL-W2	<b>3611</b>	N3522	N3449	N3349	

<sup>1</sup> NOTE: Model numbers shown in bold type are in stock. "N" model numbers require lead time and minimum quantities.

34B-W Gearmotor shown with optional "L" bracket (model 0970) and optional "accessory ready" mounting holes

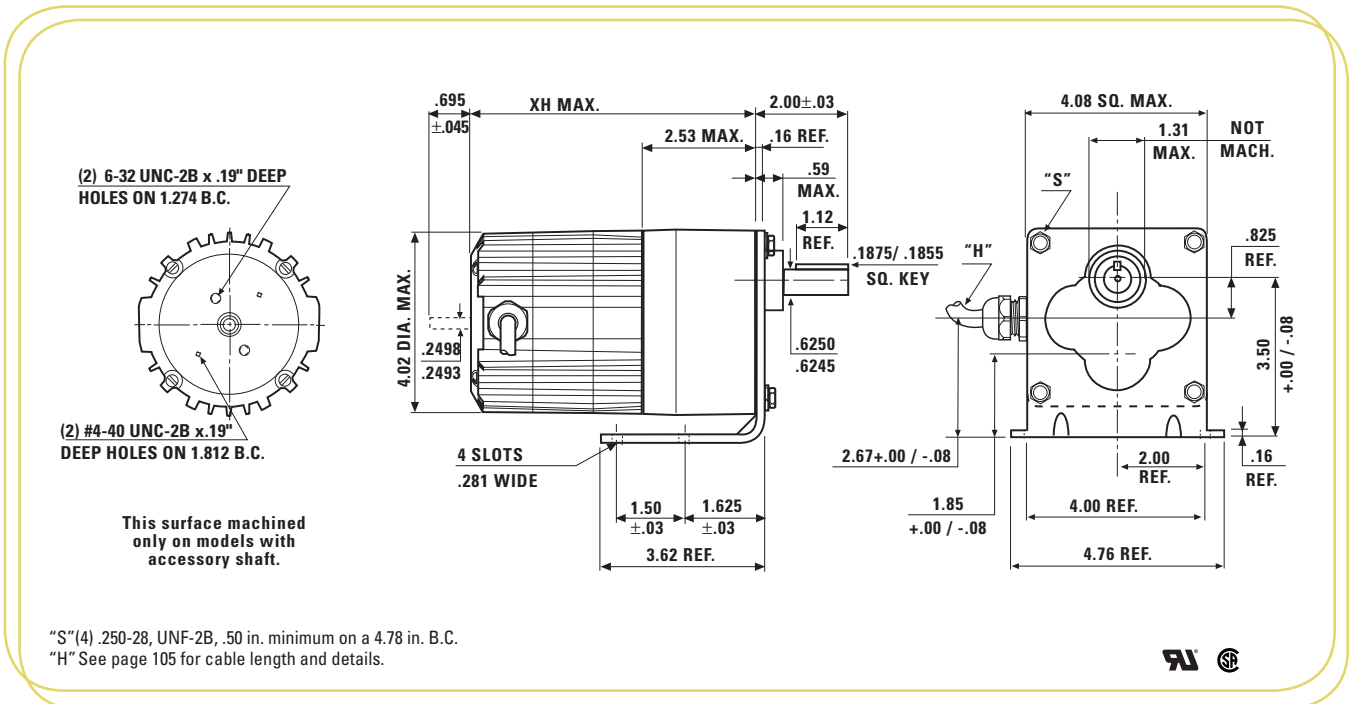



# Parallel Shaft BLDC Gearmotors

Up to 350 lb-in. continuous



34B-E and 34B-F

New

e-TORQ™

INTEGRATOR™

Hollow Shaft

Custom

Pacesetter™ Inverter Duty

AC Induction

Permanent Magnet DC

Brushless DC

Index

## Standard Features

- Brushless motor for higher torque, smaller size and no maintenance, see page 107
- Industrial lip type seals on motor and output shafts
- Needle bearings throughout for increased radial load capacity and long life
- Permanently lubricated with high-performance lubricant
- Selectively hardened all steel helical gearing for quietness and high output to size ratio

## Optional Accessories

- Encoder model 0940, see page 122
- Cable model 3983 for connection to chassis controls, see page 122
- L-Bracket kit model 0969 permits alternate mounting, see page 122
- Adaptor plate kit model 0995 provides for drop-in replacement of competitive gearmotors, see page 122

## Application Information

- Brushless motors require a control
- Electrical connections shown on page 105
- Performance ratings based on 115° C winding, 25° C ambient, and no heat sink
- Face mounting is standard

## Matching Controls

- Bodine stocks a full line of speed controls for Bodine's brushless motors, see pages 114-121



Speed (rpm)	Rated Torque (lb-in.)	Current @ Rated Torque (Amps)		Peak Torque (lb-in.)	Motor HP	Gear Ratio	Radial Load (lbs.)	Length, XH (inch)	Weight (lbs.)	Product Type	Model Number <sup>1</sup>			
		24 Volt Winding	130 Volt Winding								24 Volt Winding		130 Volt Winding	
											Accessory Shaft	No Accessory Shaft	Accessory Shaft	No Accessory Shaft
8.3	310	9.6	1.6	475	1/5	300	220	6.689	11.0	34B3BEBL-E4	-	N3575	-	N3375
14	341	9.6	1.6	475	1/5	180	200	6.689	11.0	34B3BEBL-E4	-	N3574	-	<b>3374</b>
21	350	9.6	1.6	475	1/5	120	195	6.689	11.0	34B3BEBL-E4	-	N3573	-	<b>3373</b>
42	270	12	2.0	421	1/4	60	240	7.189	12.0	34B4BEBL-E3	N3685	<b>3585</b>	N3485	<b>3385</b>
83	245	-	2.6	475	3/8	30	250	8.189	14.0	34B6BEBL-F3	-	-	-	N3372
83	135	12	2.0	318	1/4	30	300	7.189	12.0	34B4BEBL-E3	N3683	N3583	<b>3483</b>	<b>3383</b>
125	163	-	2.6	333	3/8	20	290	8.189	14.0	34B6BEBL-F3	-	-	-	N3371
125	90	12	2.0	220	1/4	20	300	7.189	12.0	34B4BEBL-E3	N3682	N3582	N3482	<b>3382</b>
250	82	-	2.6	166	3/8	10	300	8.189	14.0	34B6BEBL-F2	-	-	N3470	N3370
250	45	12	2.0	106	1/4	10	300	7.189	12.0	34B4BEBL-E2	N3680	N3580	N3480	<b>3380</b>
500	42	-	2.6	86	3/8	5	60	8.189	14.0	34B6BEBL-F1	-	-	-	<b>3369</b>
500	25	12	2.0	55	1/4	5	60	7.189	12.0	34B4BEBL-E1	-	N3579	-	<b>3379</b>

<sup>1</sup> NOTE: Model numbers shown in bold type are in stock. "N" model numbers require lead time and minimum quantities.

**34B-E Gearmotor** shown with optional "L" bracket (model 0969) and optional "accessory ready" mounting holes

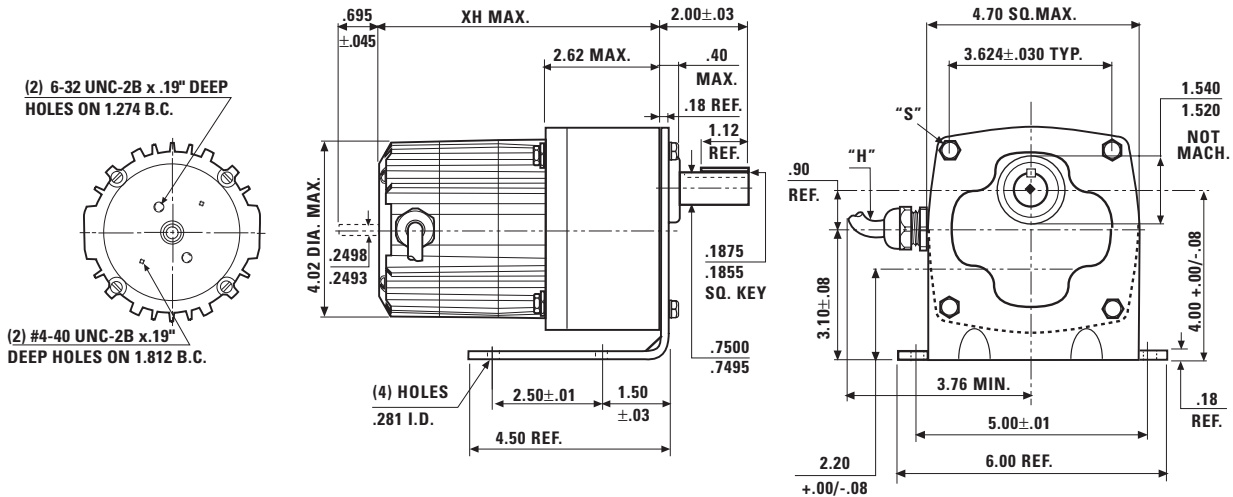

"S" (4) .1/4-28 UNF-2B, .50 in. minimum on a 5.13 in. B.C.  
 "H" See page 105 for cable length and details.



MADE IN U.S.A.

# Right Angle BLDC Gearmotors

Up to 37 lb-in. continuous



22B-3N

FOR MODELS WITH  
BUILT-IN CONTROLS

**INTEGRAmotor™**

SEE PAGES 7-10

### Standard Features

- Brushless motor for higher torque, smaller size and no maintenance, see page 106
- Industrial lip type seals on motor and output shafts
- Needle bearings on output shaft for increased radial load capacity and long life
- Permanently lubricated with high-performance lubricant
- Bronze gear for high shock load capability
- Hardened and ground worm for high strength and long life

### Application Information

- Brushless motors require a control
- Electrical connections shown on page 105
- Performance ratings are based on 115° C winding, 25° C ambient, and no heat sink

- Mounting holes are on gearhousing

- Hollow shaft configurations are available. See Web site for mounting and shaft details. These models require lead time and minimum quantities.

### Optional Accessories

- Encoder model 0940, see page 122 (requires adaptor plate model 0993 also)
- Cable model 3983 for connection to chassis controls, see page 122
- Baseplate kit model 0967, see page 122

### Matching Controls

- Bodine stocks a full line of speed controls for Bodine's brushless motors, see pages 114-121

Speed (rpm)	Rated Torque (lb-in.)	Current @ Rated Torque (Amps)		Peak Torque (lb-in.)	Motor HP	Gear Ratio	Radial Load (lbs.)	Length, XH (inch)	Weight (lbs.)	Product Type	Model Number <sup>1</sup>			
		24 Volt Winding	130 Volt Winding								24 Volt Winding		130 Volt Winding	
											Accessory Shaft	No Accessory Shaft	Accessory Shaft	No Accessory Shaft
42	37	5.9	1.0	147	1/8	60	100	8.75	5.4	22B4BEBL-3N	N3665	<b>3565</b>	N3421	N3321
62	37	5.9	1.0	123	1/8	40	90	8.75	5.4	22B4BEBL-3N	N3666	N3566	N3422	<b>3322</b>
125	35	5.9	1.0	74	1/8	20	80	8.75	5.4	22B4BEBL-3N	<b>3667</b>	N3567	N3423	N3323
250	22	5.9	1.0	46	1/8	10	70	8.75	5.4	22B4BEBL-3N	N3668	N3568	<b>3424</b>	N3324
500	11	5.9	1.0	23	1/8	5	60	8.75	5.4	22B4BEBL-3N	N3669	N3569	N3425	<b>3325</b>

<sup>1</sup> NOTE: Model numbers shown in bold type are in stock. "N" model numbers require lead time and minimum quantities.

### 22B-3N Gearmotor

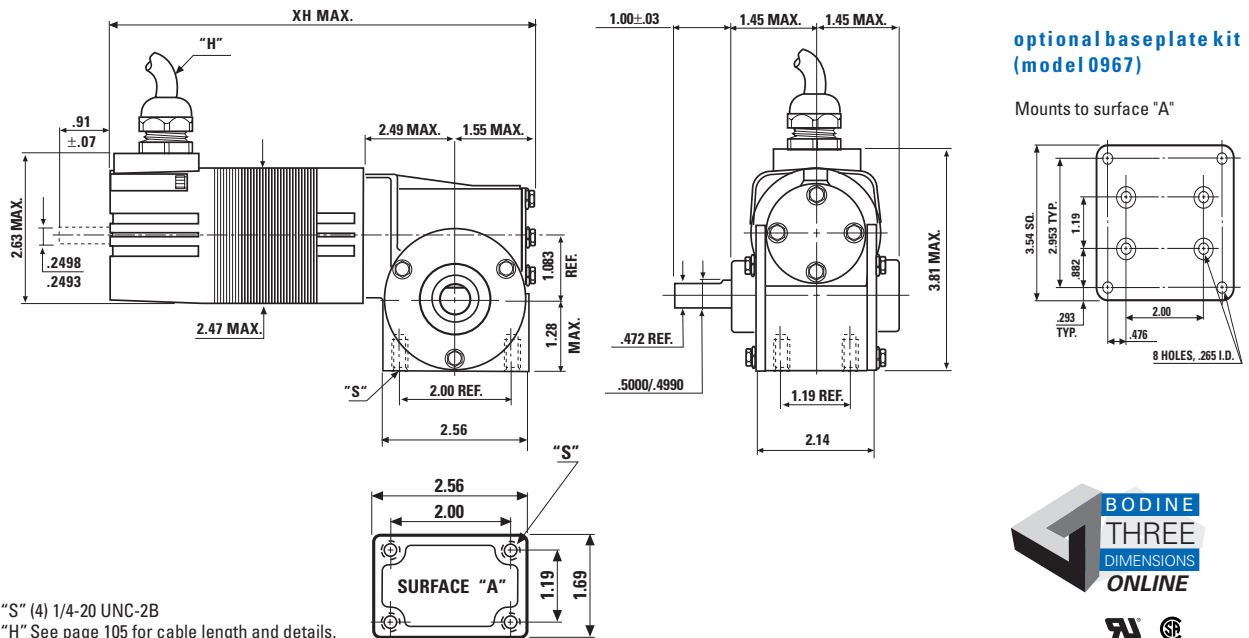

# Right Angle BLDC Gearmotors

Up to 109 lb-in. continuous

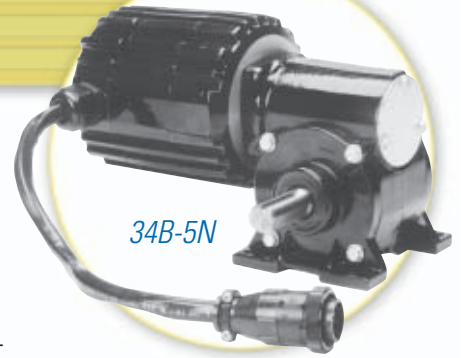

34B-5N

New  
e-TORQUE™  
INTEGRATED™

Hollow Shaft

Custom

Pacesetter™ Inverter Duty

AC Induction

Permanent Magnet DC

Brushless DC

Index

## Standard Features

- Brushless motor for higher torque, smaller size and no maintenance, see page 107
- Industrial lip type seals on motor and output shafts
- Needle bearings on output shaft for increased radial load capacity and long life
- Permanently lubricated with high-performance lubricant
- Bronze gear for high shock load capability
- Hardened and ground worm for strength and long life

- Mounting feet are on gearhousing, horizontal orientation is recommended
- Hollow shaft configurations are available. See Website for mounting and shaft details. These models require lead time and minimum quantities.

## Optional Accessories

- Encoder model 0940, see page 122
- Cable model 3983 for connection to chassis controls, see page 122

## Application Information

- Brushless motors require a control
- Electrical connections shown on page 105
- Performance ratings are based on 115° C winding, 25° C ambient, and no heat sink

## Matching Controls

- Bodine stocks a full line of speed controls for Bodine's brushless motors, see pages 114-121



Speed (rpm)	Rated Torque (lb-in.)	Current @ Rated Torque (Amps)				Motor HP	Gear Ratio	Radial Load (lbs.)	Length, XH (inch)	Weight (lbs.)	Product Type	Model Number <sup>1</sup>			
		24 Volt Winding	130 Volt Winding	24 Volt Winding								130 Volt Winding			
				Accessory Shaft	No Accessory Shaft							Accessory Shaft	No Accessory Shaft		
62	109	—	2.6	174	3/8	40	220	9.38	12	34B6BEBL-5N	—	—	—	N3396	
62	79	12	2.0	174	1/4	40	230	8.38	10	34B4BEBL-5N	N3691	N3591	N3491	N3391	
62	74	9.6	1.6	174	1/5	40	230	7.88	9	34B3BEBL-5N	—	N3586	—	<b>3386</b>	
83	104	—	2.6	166	3/8	30	210	9.38	12	34B6BEBL-5N	—	—	—	N3397	
83	75	12	2.0	166	1/4	30	210	8.38	10	34B4BEBL-5N	N3692	N3592	N3492	N3392	
83	70	9.6	1.6	166	1/5	30	210	7.88	9	34B3BEBL-5N	—	N3587	—	N3387	
125	98	—	2.6	156	3/8	20	180	9.38	12	34B6BEBL-5N	—	—	—	N3398	
125	75	12	2.0	156	1/4	20	180	8.38	10	34B4BEBL-5N	N3693	N3593	<b>3493</b>	N3393	
125	59	9.6	1.6	156	1/5	20	180	7.88	9	34B3BEBL-5N	—	N3588	—	N3388	
250	64	—	2.6	161	3/8	10	140	9.38	12	34B6BEBL-5N	—	—	—	<b>3399</b>	
250	42	12	2.0	161	1/4	10	140	8.38	10	34B4BEBL-5N	N3694	N3594	N3494	N3394	
250	33	9.6	1.6	140	1/5	10	150	7.88	9	34B3BEBL-5N	—	N3589	—	N3389	
500	36	—	2.6	142	3/8	5	120	9.38	12	34B6BEBL-5N	—	—	—	N3378	
500	24	12	2.0	94	1/4	5	120	8.38	10	34B4BEBL-5N	N3695	N3595	N3495	N3395	
500	18.6	9.6	1.6	74	1/5	5	120	7.88	9	34B3BEBL-5N	—	N3590	—	N3390	

<sup>1</sup> NOTE: Model numbers shown in bold type are in stock. "N" model numbers require lead time and minimum quantities.

34B-5N Gearmotor shown with optional "accessory ready" mounting holes

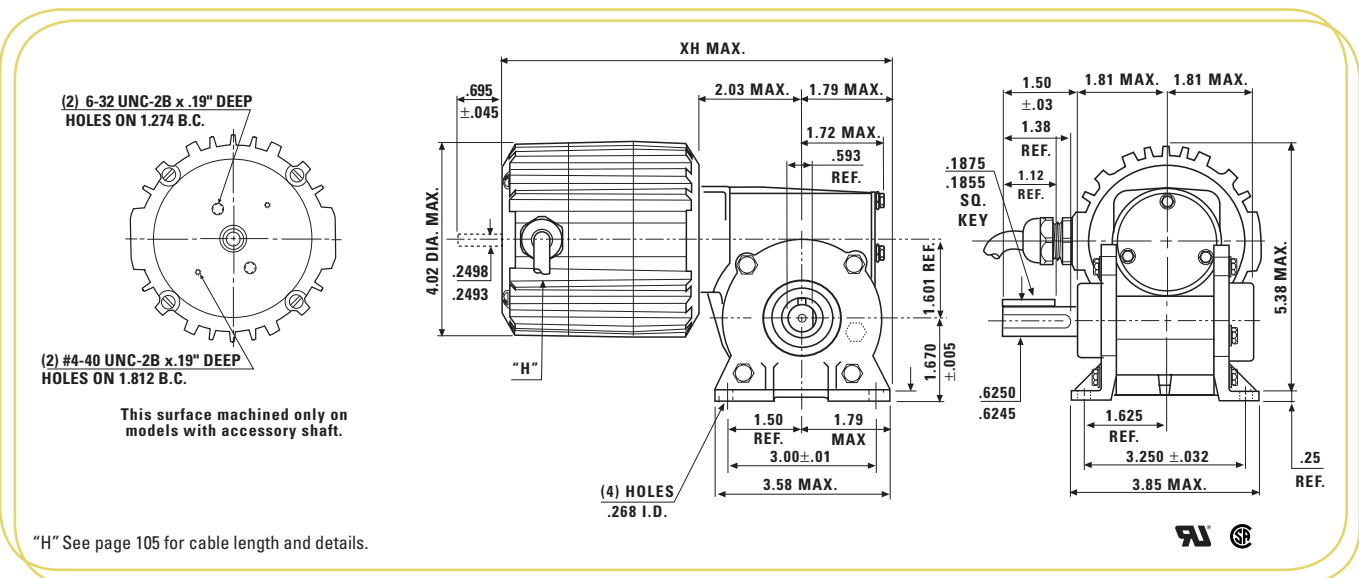

MADE IN U.S.A.

# BLDC Motor Controls

A variety of  
**products**  
to fit  
a variety of  
**applications**

## Low Voltage 24 VDC Controls

See pages 115



Can operate from battery (or back-up) power supply

## Open Chassis Controls

See page 115 for 24 VDC;  
Unfiltered – page 118;  
Filtered – page 116



For lowest cost and when an enclosure is already available

## Filtered 115 VAC Controls

See page 116 for Open Chassis;  
Enclosed – page 117

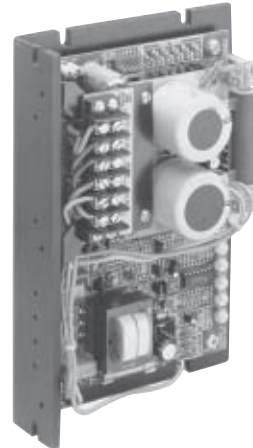

For cooler motor operation and wider speed range

## Controls for High Speed Motors

See page 116 for Open Chassis;  
Enclosed – page 117

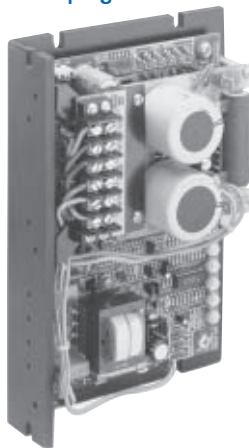

Drives are matched to motors for up to 10,000 rpm

## NEMA 1 Enclosures

See page 117 for 115 VAC



With a convenient user interface and basic environmental protection

# Low Voltage PWM BLDC Controls

## Chassis, Speed and Direction Control



ABL

**2 YEAR**  
SYSTEM WARRANTY  
SEE PAGE 128

### Standard Features

- 24 Volt power requirement makes this control ideal for portable, battery-operated applications or applications where safety standards dictate a low operating voltage
- On-board speed potentiometer for manual adjustment
- Accepts 0-5 VDC analog signal for remote operation
- Unique Smart Reverse™ circuit provides quick reversing and prevents motor plugging
- Dynamic braking for quicker stops
- 12 pulse/revolution tach output provides indication of motor speed
- Logic output indicates control shutdown due to a motor overload
- Speed can be adjusted manually or by remote

control over a range of 30:1

- Inherent closed loop system maintains a 2% maximum change in motor speed from 0 - 100% of rated load when operated at rated speed

### Application Information

- Rated for 50° C ambient.
- To be mounted in separate enclosure supplied by user
- Drives 24 volt Bodine brushless motors shown on pages 106-113
- Requires an unregulated 24 VDC power supply with a minimum 5000 MFD capacitance
- 20 kHz PWM switching frequency
- For selection table, see page 119

HP Rating	Input Voltage (VDC)	Output Voltage (VDC)	Continuous Output Current (Amps)	Peak Output Current (Amps)	Form Factor	Weight (lbs.)	Product Type	Model Number
1/6	24-35	0-24	10.0	13.5	1.0	2.0	ABL-3905C	3905
1/4	24-35	0-24	15.0	22	1.0	2.0	ABL-3907C	3907

### Dimensions

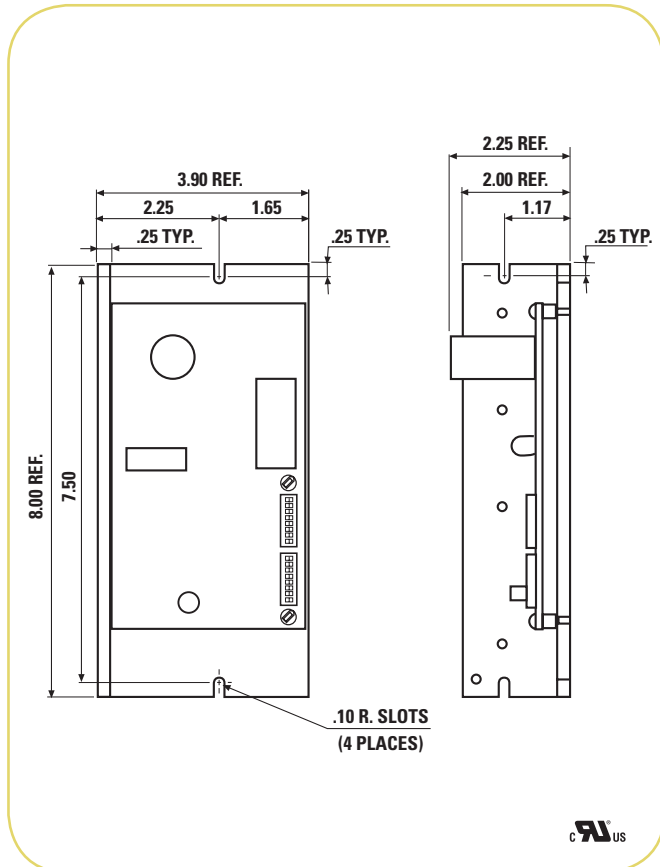

### Connection Diagram

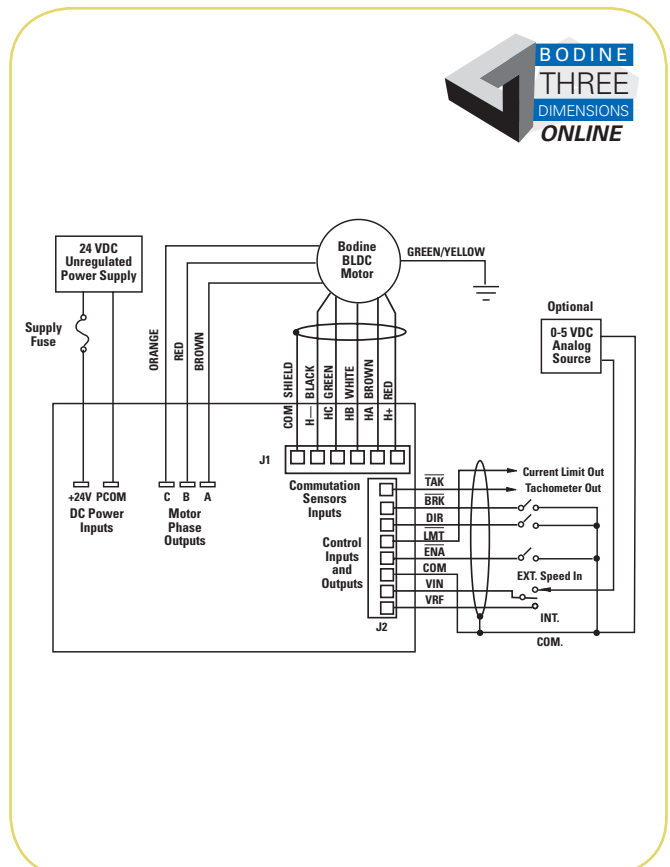

# Filtered SCR BLDC Controls

## Chassis, Speed and Direction Control

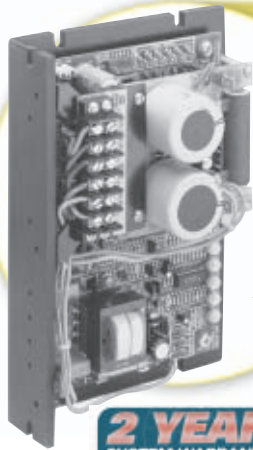

ABL

**2 YEAR**  
SYSTEM WARRANTY  
SEE PAGE 128

### Standard Features

- Operates from 115 Volt AC line
- Filtered DC output results in cooler operation of the motor
- Unique Smart Reverse™ circuit for remote control of motor direction
- Dynamic braking for quicker stops
- 12 pulse/revolution tach output provides indication of motor speed
- Green LED indicates AC power on
- Red LED indicates control shutdown due to a fault condition
- Speed can be adjusted manually with a remote 10K ohm potentiometer (included)
- DIP switches set the current limit so that the same control model can drive any size Bodine motor
- Five onboard user-adjustable pots for torque limit, minimum speed limit, maximum speed limit, acceleration time and deceleration time
- Fuseholders for line and motor fuses (fuses included)
- Inherent closed loop system maintains a 1% maximum change in motor speed from 0 - 100% of rated load when operated at rated speed

### Application Information

- Rated for 50° C ambient
- Intended to be mounted in separate enclosure supplied by user
- Drives 130 V brushless motors shown on page 106-113
- Screw terminal block for line and motor connections
- Plug-in connector for commutation connections
- .25" quick connect tabs for user interface connections
- Model 3911 for 2500 rpm motors. Model 3921 for 10,000 rpm motors
- See page 120 for selection tables

### Optional Accessories

- Model 3983 cable connection assembly, see page 122
- Model 3982 cable extension, see page 122
- Model 3984 analog interface and isolation module, see page 122

HP Rating	Input Voltage (VAC, 50/60 Hz)	Output Voltage (VDC)	Continuous Output Current (Amps)	Peak Output Current (Amps)	Form Factor	Weight (lbs.)	Product Type	Model Number
3/8 @ 2500 rpm	115	0-130	3.0	6.0	1.0	2.5	ABL-3911C	<b>3911</b>
1/3 @ 10,000 rpm	115	0-130	3.0	6.0	1.0	2.5	ABL-3921C	<b>3921</b>

### Dimensions

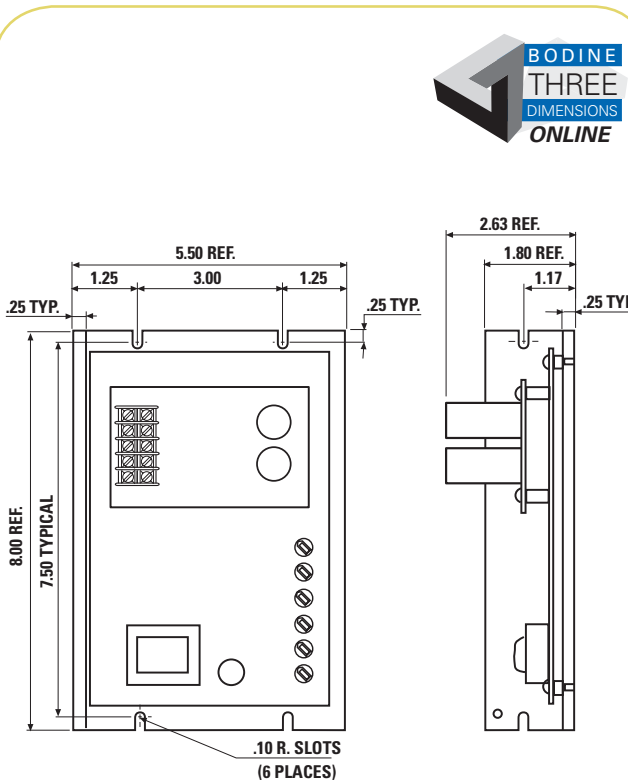

### Connection Diagram

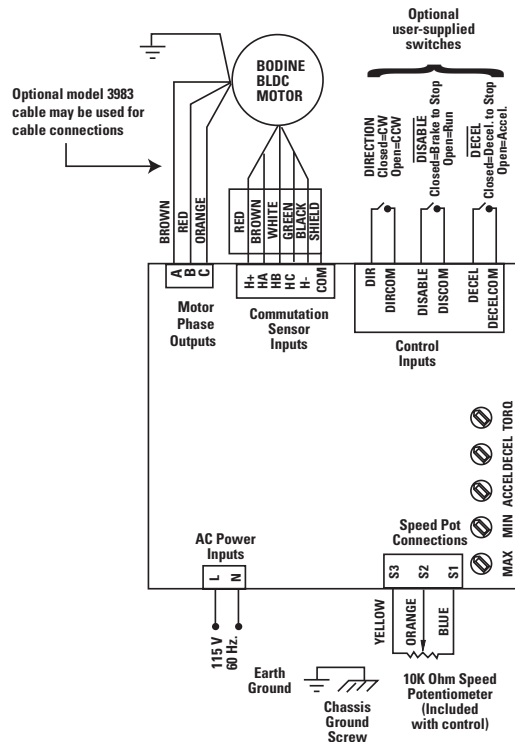

User must supply wire for all external connections

# Filtered SCR BLDC Controls

## NEMA 12, Speed and Direction Control



ABL

**2 YEAR**  
SYSTEM WARRANTY  
SEE PAGE 128

### Standard Features

- Operates from 115 Volt AC line
- Filtered DC output results in cooler operation of the motor
- Unique Smart Reverse™ circuit allows remote control of motor direction
- NEMA 12 enclosure for environmental protection
- Dynamic braking for quicker stops
- 12 pulse/revolution tach output provides indication of motor speed
- Red LED indicates control shutdown due to a fault condition
- Speed can be adjusted manually using potentiometer on enclosure
- DIP switches set the current limit so that the same control model can drive any size Bodine motor
- Inherent closed loop system maintains a 1% maximum change in motor speed from 0 - 100% of rated load when operated at rated speed
- Toggle switch on enclosure to turn AC power on/off
- Lamp on enclosure indicates AC power on

- Rotary switch on enclosure to select motor direction
- Fuseholders for line and motor fuses (included)
- AC line cable and motor cable factory-installed

### Application Information

- Rated for 40° C ambient
- Drives 130 V brushless motors shown on pages 106-113
- Two means of mounting: face mounting using self-tapping screws on back surface, or flange mounting by installing four brackets (included)
- Model 3912 for 2500 rpm motors. Model 3913 for 10,000 rpm motors.
- For selection tables, see page 120

### Optional Accessories

- Model 3982 cable extension, see page 122
- IP44 sealing kit model 0895 for protection against splashing water, see page 122

HP Rating	Input Voltage (VAC, 50/60 Hz)	Output Voltage (VDC)	Continuous Output Current (Amps)	Peak Output Current (Amps)	Form Factor	Weight (lbs.)	Product Type	Model Number <sup>1</sup>
3/8 @ 2500 rpm	115	0-130	3.0	6.0	1.0	7.5	ABL-3912E	<b>3912</b>
1/3 @ 10,000 rpm	115	0-130	3.0	6.0	1.0	7.5	ABL-3913E	<b>N3913</b>

<sup>1</sup> NOTE: Model numbers shown in bold type are in stock. "N" model numbers require lead time and minimum quantities.

### Dimensions And Connections

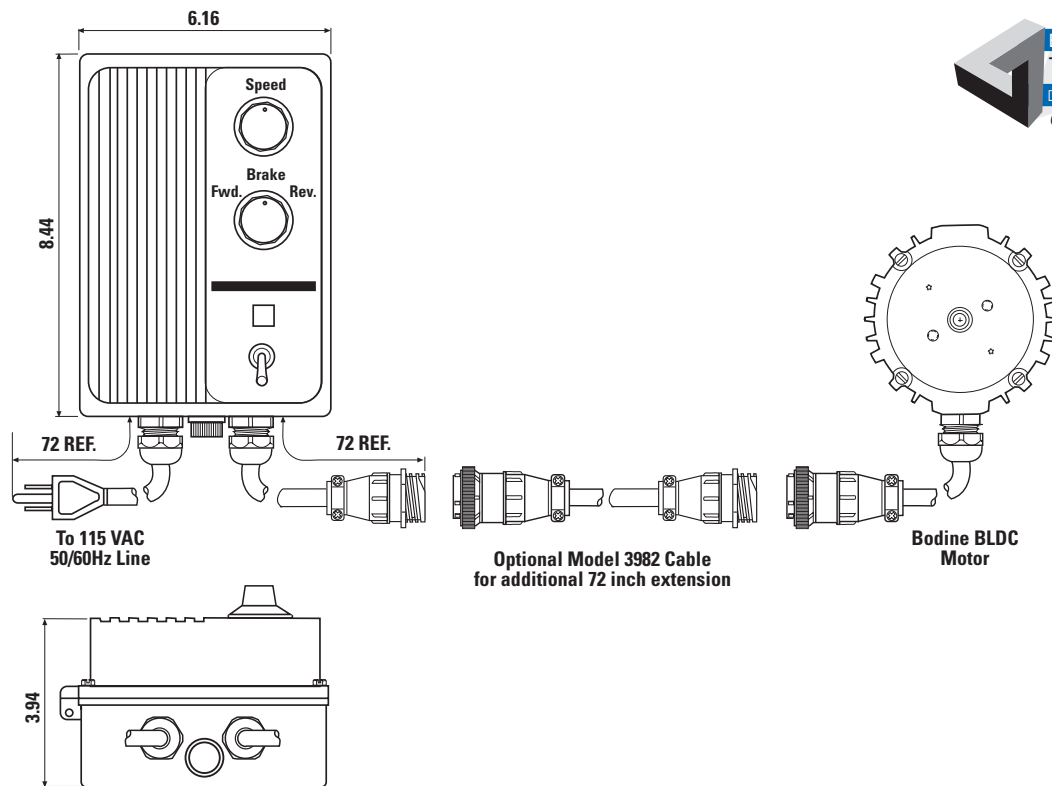

# Unfiltered SCR BLDC Controls

Chassis, Speed and Direction Control

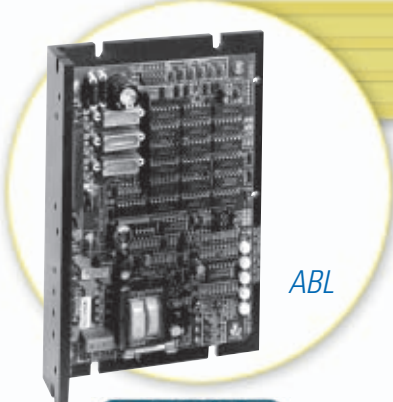

ABL

**2 YEAR**  
SYSTEM WARRANTY  
SEE PAGE 128

### Standard Features

- Operates from 115 Volt AC line
- Unique Smart Reverse™ circuit allows remote control of motor direction
- 12 pulse/revolution tach output provides indication of motor speed
- Green LED indicates AC power on
- Red LED indicates control shutdown due to a fault condition
- Speed can be adjusted manually with a remote 10K ohm potentiometer (not included)
- DIP switches set the current limit so that the same control model can drive any size Bodine motor
- Inherent closed loop system maintains a 1% maximum change in motor speed from 0 - 100% of rated load when operated at rated speed
- Fuseholder for line and motor fuses (line fuse only included)

### Application Information

- Rated for 50° C ambient
- Intended to be mounted in separate enclosure supplied by user
- Drives 130 V brushless motors shown on pages 106-113
- .25 inch quick connect tabs for line, motor connections, and user interface connections
- Plug-in connector for commutation connections
- For selection table, see page 121

### Optional Accessories

- Model 3983 cable connection assembly, see page 122
- Model 3982 cable extension, see page 122
- Model 3984 analog interface and isolation module, see page 122
- Fuse and speed potentiometer kit (part number 433 00270), see page 122

HP Rating	Input Voltage (VAC, 50/60 Hz)	Output Voltage (VDC)	Continuous Output Current (Amps)	Peak Output Current (Amps)	Form Factor	Weight (lbs.)	Product Type	Model Number
3/8	115	0-90	3.0	6.0	1.6	2.5	ABL-3910C	3910

### Dimensions

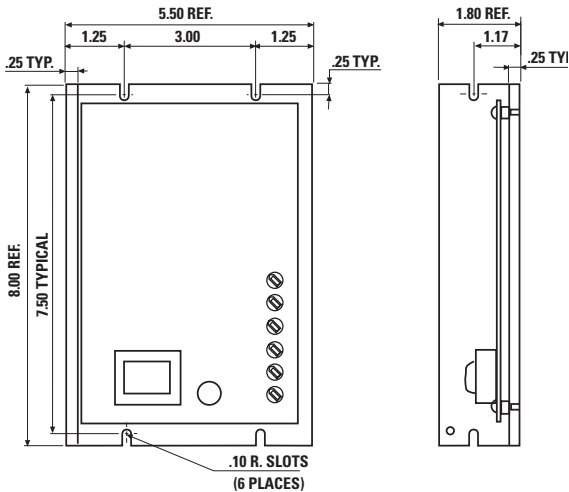

### Connection Diagram

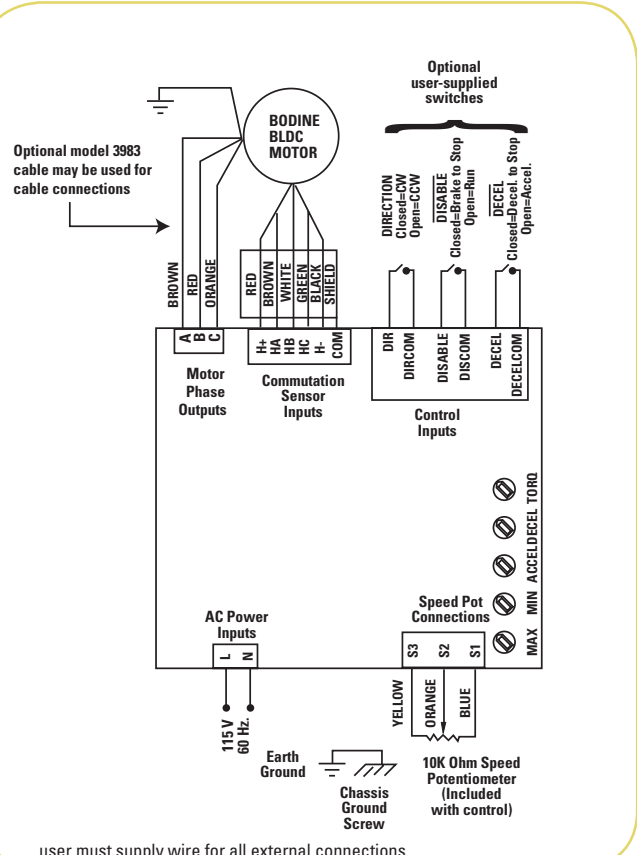

user must supply wire for all external connections



# Low Voltage Chassis BLDC Controls

## Type ABL Selection Table

### SYSTEM PERFORMANCE WHEN USING BODINE 24V BLDC MOTORS WITH BODINE LOW VOLTAGE BLDC CONTROLS

		Motor/Gearmotor Specifications					Matching Control Model Numbers
		Model Number		Product Type	Nameplate Rating (HP)	Reference Page	Chassis
Speed Range (rpm)	Continuous Torque (lb-in.)	Accessory Shaft <sup>1</sup>	No Accessory Shaft <sup>1</sup>				
<b>Motors Without Gear Reducers</b>							
150 - 2500	1.6	–	<b>3502</b>	22B2BEBL	1/16	106	<b>3905</b>
150 - 2500	3.1	<b>3604</b>	N3504	22B4BEBL	1/8	106	<b>3905</b>
150 - 2500	5.1	<b>3600</b>	N3500	34B3BEBL	1/5	107	<b>3907</b>
150 - 2500	6.3	–	N3507	34B4BEBL	1/4	107	<b>3907</b>
<b>Parallel Shaft Gearmotors</b>							
0.6 - 14	40	N3636	N3536	22B2BEBL-D4	1/16	108	<b>3905</b>
0.6 - 14	100	–	N3563	22B2BEBL-Z4	1/16	109	<b>3905</b>
0.8 - 21	100	–	N3564	22B2BEBL-Z4	1/16	109	<b>3905</b>
1.2 - 28	40	N3635	N3535	22B2BEBL-D4	1/16	108	<b>3905</b>
1.2 - 28	100	–	N3562	22B2BEBL-Z4	1/16	109	<b>3905</b>
1.7 - 42	40	N3634	N3534	22B2BEBL-D3	1/16	108	<b>3905</b>
3.3 - 83	29	<b>3629</b>	N3529	22B2BEBL-D3	1/16	108	<b>3905</b>
5.6 - 139	17	N3628	N3528	22B2BEBL-D3	1/16	108	<b>3905</b>
8.3 - 208	12	N3627	N3527	22B2BEBL-D3	1/16	108	<b>3905</b>
17 - 417	5.8	N3626	N3526	22B2BEBL-D3	1/16	108	<b>3905</b>
1.7 - 42	95	<b>3661</b>	N3561	22B3BEBL-Z3	1/11	109	<b>3905</b>
3.3 - 83	52	N3660	N3560	22B3BEBL-Z3	1/11	109	<b>3905</b>
5.6 - 139	31	N3659	N3559	22B3BEBL-Z2	1/11	109	<b>3905</b>
8.3 - 208	20	N3658	N3558	22B3BEBL-Z2	1/11	109	<b>3905</b>
17 - 417	10	N3657	N3557	22B3BEBL-Z2	1/11	109	<b>3905</b>
0.3 - 8.1	75	N3647	N3547	34B3BEBL-W4	1/5	110	<b>3905</b>
0.3 - 8.3	310	–	N3575	34B3BEBL-E4	1/5	111	<b>3905</b>
0.6 - 14	166	N3624	N3524	34B3BEBL-W4	1/5	110	<b>3905</b>
0.6 - 14	341	–	N3574	34B3BEBL-E4	1/5	111	<b>3905</b>
1.0 - 26	154	N3656	N3556	34B3BEBL-W4	1/5	110	<b>3905</b>
1.5 - 38	143	N3617	N3517	34B3BEBL-W3	1/5	110	<b>3905</b>
3.3 - 84	65	N3653	N3553	34B3BEBL-W3	1/5	110	<b>3905</b>
4.9 - 122	46	N3652	N3552	34B3BEBL-W2	1/5	110	<b>3905</b>
11 - 266	21	N3623	N3523	34B3BEBL-W2	1/5	110	<b>3905</b>
18 - 456	12	<b>3611</b>	N3522	34B3BEBL-W2	1/5	110	<b>3905</b>
0.8 - 21	350	–	N3573	34B4BEBL-E4	1/4	111	<b>3907</b>
1.7 - 42	270	N3685	<b>3585</b>	34B4BEBL-E3	1/4	111	<b>3907</b>
3 - 83	135	N3683	N3583	34B4BEBL-E3	1/4	111	<b>3907</b>
5 - 125	90	N3682	N3582	34B4BEBL-E3	1/4	111	<b>3907</b>
10 - 250	45	N3680	N3580	34B4BEBL-E2	1/4	111	<b>3907</b>
20 - 500	25	–	N3579	34B4BEBL-E1	1/4	111	<b>3907</b>
<b>Right Angle Gearmotors</b>							
1.7 - 42	37	N3665	<b>3565</b>	22B4BEBL-3N	1/8	112	<b>3905</b>
2.5 - 62	37	N3666	N3566	22B4BEBL-3N	1/8	112	<b>3905</b>
5 - 125	35	<b>3667</b>	N3567	22B4BEBL-3N	1/8	112	<b>3905</b>
10 - 250	22	N3668	N3568	22B4BEBL-3N	1/8	112	<b>3905</b>
20 - 500	11	N3669	N3569	22B4BEBL-3N	1/8	112	<b>3905</b>
2.5 - 62	74	–	N3586	34B3BEBL-5N	1/5	113	<b>3907</b>
3.3 - 83	70	–	N3587	34B3BEBL-5N	1/5	113	<b>3907</b>
5 - 125	67	–	N3588	34B3BEBL-5N	1/5	113	<b>3907</b>
10 - 250	33	–	N3589	34B3BEBL-5N	1/5	113	<b>3907</b>
20 - 500	18.6	–	N3590	34B3BEBL-5N	1/5	113	<b>3907</b>
2.5 - 62	79	N3691	N3591	34B4BEBL-5N	1/4	113	<b>3907</b>
3.3 - 83	75	N3692	N3592	34B4BEBL-5N	1/4	113	<b>3907</b>
5 - 125	75	N3693	N3593	34B4BEBL-5N	1/4	113	<b>3907</b>
10 - 250	42	N3694	N3594	34B4BEBL-5N	1/4	113	<b>3907</b>
20 - 500	24	N3695	N3595	34B4BEBL-5N	1/4	113	<b>3907</b>

<sup>1</sup> NOTE: Model numbers shown in bold type are in stock. "N" model numbers require lead time and minimum quantities.

NOTE: Some of the newer motors shown in this catalog do not yet appear in these tables. Refer to [www.bodine-electric.com](http://www.bodine-electric.com) for the most up-to-date information.

# Filtered Chassis BLDC Controls

## Type ABL Selection Table

SYSTEM PERFORMANCE WHEN USING BODINE 130V BLDC MOTORS WITH BODINE FILTERED BLDC CONTROLS (130 VDC OUTPUT)

Motor/Gearmotor Specifications							Matching Control Model Numbers	
Speed Range (rpm)	Cont. Torque (lb-in.)	Model Number		Product Type	Nameplate Rating (HP)	Reference Page	Encased	Chassis
		Accessory Shaft <sup>1</sup>	No Accessory Shaft <sup>1</sup>					
<b>Motors Without Gear Reducers</b>								
150 - 2500	1.6	–	<b>3302</b>	22B2BEBL	1/16	106	<b>3912</b>	<b>3911</b>
150 - 2500	3.1	<b>3404</b>	<b>3304</b>	22B4BEBL	1/8	106	<b>3912</b>	<b>3911</b>
100 - 2500	5.1	N3406	<b>3306</b>	34B3BEBL	1/5	107	<b>3912</b>	<b>3911</b>
400 - 10,000	1.2	–	<b>3314</b>	22B4BEBL	1/5	106	N3913	<b>3921</b>
100 - 2500	6.3	–	N3307	34B4BEBL	1/4	107	<b>3912</b>	<b>3911</b>
400 - 10,000	2.1	–	<b>3317</b>	34B4BEBL	1/3	107	N3913	<b>3921</b>
100 - 2500	9.4	<b>3409</b>	<b>3309</b>	34B6BEBL	3/8	107	<b>3912</b>	<b>3911</b>
<b>Parallel Shaft Gearmotors</b>								
0.6 - 14	40	N3433	<b>3333</b>	22B2BEBL-D4	1/16	108	<b>3912</b>	<b>3911</b>
0.8 - 21	100	–	N3364	22B2BEBL-Z4	1/16	109	<b>3912</b>	<b>3911</b>
1.2 - 28	40	N3431	N3331	22B2BEBL-D4	1/16	108	<b>3912</b>	<b>3911</b>
1.7 - 42	40	N3430	N3330	22B2BEBL-D3	1/16	108	<b>3912</b>	<b>3911</b>
3 - 83	29	N3429	<b>3329</b>	22B2BEBL-D3	1/16	108	<b>3912</b>	<b>3911</b>
5.6 - 139	17	N3428	N3328	22B2BEBL-D3	1/16	108	<b>3912</b>	<b>3911</b>
8.3 - 208	12	N3427	<b>3327</b>	22B2BEBL-D3	1/16	108	<b>3912</b>	<b>3911</b>
17 - 417	5.8	N3426	<b>3326</b>	22B2BEBL-D3	1/16	108	<b>3912</b>	<b>3911</b>
0.6 - 14	100	N3463	<b>3363</b>	22B3BEBL-Z4	1/11	109	<b>3912</b>	<b>3911</b>
1.2 - 28	100	N3462	N3362	22B3BEBL-Z4	1/11	109	<b>3912</b>	<b>3911</b>
1.7 - 42	95	N3461	N3361	22B3BEBL-Z3	1/11	109	<b>3912</b>	<b>3911</b>
3 - 83	52	N3460	N3360	22B3BEBL-Z3	1/11	109	<b>3912</b>	<b>3911</b>
5.6 - 139	31	N3459	N3359	22B3BEBL-Z2	1/11	109	<b>3912</b>	<b>3911</b>
8.3 - 208	20	N3458	<b>3358</b>	22B3BEBL-Z2	1/11	109	<b>3912</b>	<b>3911</b>
17 - 417	10	N3457	<b>3357</b>	22B3BEBL-Z2	1/11	109	<b>3912</b>	<b>3911</b>
0.3 - 8	175	N3447	N3347	34B3BEBL-W4	1/5	110	<b>3912</b>	<b>3911</b>
0.3 - 8.3	310	–	N3375	34B3BEBL-E4	1/5	111	<b>3912</b>	<b>3911</b>
0.6 - 14	341	–	<b>3374</b>	34B3BEBL-E4	1/5	111	<b>3912</b>	<b>3911</b>
0.6 - 14	166	N3446	<b>3346</b>	34B3BEBL-W4	1/5	110	<b>3912</b>	<b>3911</b>
0.8 - 21	350	–	<b>3373</b>	34B3BEBL-E4	1/5	111	<b>3912</b>	<b>3911</b>
1 - 26	154	N3456	N3356	34B3BEBL-W4	1/5	110	<b>3912</b>	<b>3911</b>
1.5 - 38	143	N3455	N3355	34B3BEBL-W3	1/5	110	<b>3912</b>	<b>3911</b>
3.3 - 84	65	N3453	<b>3353</b>	34B3BEBL-W3	1/5	110	<b>3912</b>	<b>3911</b>
4.9 - 122	46	N3452	<b>3352</b>	34B3BEBL-W2	1/5	110	<b>3912</b>	<b>3911</b>
11 - 266	21	N3450	N3350	<i>34B3BEBL-W2</i>	<i>1/5</i>	<i>110</i>	<b>3912</b>	<b>3911</b>
18 - 456	12	N3449	N3349	34B3BEBL-W2	1/5	110	<b>3912</b>	<b>3911</b>
1.7 - 42	270	N3485	<b>3385</b>	34B4BEBL-E3	1/4	111	<b>3912</b>	<b>3911</b>
3 - 83	135	<b>3483</b>	<b>3383</b>	34B4BEBL-E3	1/4	111	<b>3912</b>	<b>3911</b>
5 - 125	90	N3482	N3382	34B4BEBL-E3	1/4	111	<b>3912</b>	<b>3911</b>
10 - 250	45	N3480	<b>3380</b>	34B4BEBL-E2	1/4	111	<b>3912</b>	<b>3911</b>
20 - 500	25	–	<b>3379</b>	34B4BEPM-E1	1/4	111	<b>3912</b>	<b>3911</b>
3 - 83	245	–	N3372	34B6BEBL-F3	3/8	111	<b>3912</b>	<b>3911</b>
5 - 125	163	–	N3371	34B6BEBL-F3	3/8	111	<b>3912</b>	<b>3911</b>
10 - 250	82	N3470	N3370	34B6BEBL-F2	3/8	111	<b>3912</b>	<b>3911</b>
20 - 500	42	–	<b>3369</b>	34B6BEBL-F1	3/8	111	<b>3912</b>	<b>3911</b>
<b>Right Angle Gearmotors</b>								
1.7 - 42	37	N3421	N3321	22B4BEBL-3N	1/8	112	<b>3912</b>	<b>3911</b>
2.5 - 62	37	N3422	<b>3322</b>	22B4BEBL-3N	1/8	112	<b>3912</b>	<b>3911</b>
5 - 125	35	N3423	N3323	22B4BEBL-3N	1/8	112	<b>3912</b>	<b>3911</b>
10 - 250	22	<b>3424</b>	N3324	22B4BEBL-3N	1/8	112	<b>3912</b>	<b>3911</b>
20 - 500	11	N3425	<b>3325</b>	22B4BEBL-3N	1/8	112	<b>3912</b>	<b>3911</b>
2.5 - 62	74	–	<b>3386</b>	34B3BEBL-5N	1/5	113	<b>3912</b>	<b>3911</b>
3 - 83	70	–	N3387	34B3BEBL-5N	1/5	113	<b>3912</b>	<b>3911</b>
5 - 125	59	–	N3388	34B3BEBL-5N	1/5	113	<b>3912</b>	<b>3911</b>
10 - 250	33	–	N3389	34B3BEBL-5N	1/5	113	<b>3912</b>	<b>3911</b>
20 - 500	18.6	–	N3390	34B3BEBL-5N	1/5	113	<b>3912</b>	<b>3911</b>
2.5 - 62	79	N3491	N3391	34B4BEBL-5N	1/4	113	<b>3912</b>	<b>3911</b>
3 - 83	75	N3492	N3392	34B4BEBL-5N	1/4	113	<b>3912</b>	<b>3911</b>
5 - 125	75	<b>3493</b>	N3393	34B4BEBL-5N	1/4	113	<b>3912</b>	<b>3911</b>
10 - 250	42	N3494	N3394	34B4BEBL-5N	1/4	113	<b>3912</b>	<b>3911</b>
20 - 500	24	N3495	N3395	34B4BEBL-5N	1/4	113	<b>3912</b>	<b>3911</b>
2.5 - 62	109	–	N3396	34B6BEBL-5N	3/8	113	<b>3912</b>	<b>3911</b>
3 - 83	104	–	N3397	34B6BEBL-5N	3/8	113	<b>3912</b>	<b>3911</b>
5 - 125	98	–	N3398	34B6BEBL-5N	3/8	113	<b>3912</b>	<b>3911</b>
10 - 250	64	–	<b>3399</b>	34B6BEBL-5N	3/8	113	<b>3912</b>	<b>3911</b>
20 - 500	36	–	N3378	34B6BEBL-5N	3/8	113	<b>3912</b>	<b>3911</b>

<sup>1</sup> NOTE: Model numbers shown in bold type are in stock. "N" model numbers require lead time and minimum quantities.

# Unfiltered Chassis BLDC Controls

## Type ABL Selection Table

### SYSTEM PERFORMANCE WHEN USING BODINE 130V BLDC MOTORS WITH BODINE UNFILTERED BLDC CONTROLS (90 VDC OUTPUT)

Speed Range (rpm)		Cont. Torque (lb-in.)		Motor or Gearmotor Specifications			Reference Page	Matching Control Model Numbers
				Model Number		Product Type		
		Accessory Shaft <sup>1</sup>	No Accessory Shaft				Chassis	
<b>Motors Without Gear Reducers</b>								
150 - 1725	1.1	—	<b>3302</b>	22B2BEBL	1/16	106	<b>3910</b>	
150 - 1725	2.6	<b>3404</b>	<b>3304</b>	22B4BEBL	1/8	106	<b>3910</b>	
100 - 1725	3.3	N3406	<b>3306</b>	34B3BEBL	1/5	107	<b>3910</b>	
100 - 1725	4.1	—	N3307	34B4BEBL	1/4	107	<b>3910</b>	
100 - 1725	6.1	<b>3409</b>	<b>3309</b>	34B6BEBL	3/8	107	<b>3910</b>	
<b>Parallel Shaft Gearmotors</b>								
0.6 - 9.6	40	N3433	<b>3333</b>	22B2BEBL-D4	1/16	108	<b>3910</b>	
0.8 - 14	100	—	N3364	22B2BEBL-Z4	1/16	109	<b>3910</b>	
1.2 - 20	40	N3431	N3331	22B2BEBL-D4	1/16	108	<b>3910</b>	
1.7 - 29	40	N3430	N3330	22B2BEBL-D3	1/16	108	<b>3910</b>	
3 - 58	24	N3429	<b>3329</b>	22B2BEBL-D3	1/16	108	<b>3910</b>	
5.6 - 96	15	N3428	N3328	22B2BEBL-D3	1/16	108	<b>3910</b>	
8.3 - 144	9.8	N3427	<b>3327</b>	22B2BEBL-D3	1/16	108	<b>3910</b>	
17 - 288	4.6	N3426	<b>3326</b>	22B2BEBL-D3	1/16	108	<b>3910</b>	
0.6 - 9.6	100	N3463	<b>3363</b>	22B3BEBL-Z4	1/11	109	<b>3910</b>	
1.2 - 20	100	N3462	N3362	22B3BEBL-Z4	1/11	109	<b>3910</b>	
1.7 - 29	95	N3461	N3361	22B3BEBL-Z3	1/11	109	<b>3910</b>	
3 - 58	38	N3460	N3360	22B3BEBL-Z3	1/11	109	<b>3910</b>	
5.6 - 96	24	N3459	N3359	22B3BEBL-Z2	1/11	109	<b>3910</b>	
8.3 - 144	16	N3458	<b>3358</b>	22B3BEBL-Z2	1/11	109	<b>3910</b>	
17 - 288	8	N3457	<b>3357</b>	22B3BEBL-Z2	1/11	109	<b>3910</b>	
0.3 - 5.6	175	N3447	N3347	34B3BEBL-W4	1/5	110	<b>3910</b>	
0.3 - 5.8	310	—	N3375	34B3BEBL-E4	1/5	111	<b>3910</b>	
0.6 - 9.6	341	—	<b>3374</b>	34B3BEBL-E4	1/5	111	<b>3910</b>	
0.6 - 9.6	166	N3446	<b>3346</b>	34B3BEBL-W4	1/5	110	<b>3910</b>	
0.8 - 14	299	—	<b>3373</b>	34B3BEBL-E4	1/5	111	<b>3910</b>	
1 - 18	154	N3456	N3356	34B3BEBL-W4	1/5	110	<b>3910</b>	
1.5 - 26	143	N3455	N3355	34B3BEBL-W3	1/5	110	<b>3910</b>	
3.3 - 58	64	N3453	<b>3353</b>	34B3BEBL-W3	1/5	110	<b>3910</b>	
4.9 - 85	46	N3452	<b>3352</b>	34B3BEBL-W2	1/5	110	<b>3910</b>	
11 - 184	21	N3450	N3350	34B3BEBL-W2	1/5	110	<b>3910</b>	
18 - 315	12	N3449	N3349	34B3BEBL-W2	1/5	110	<b>3910</b>	
1.7 - 29	199	N3485	<b>3385</b>	34B4BEBL-E3	1/4	111	<b>3910</b>	
3 - 58	100	<b>3483</b>	<b>3383</b>	34B4BEBL-E3	1/4	111	<b>3910</b>	
5 - 86	66	N3482	N3382	34B4BEBL-E3	1/4	111	<b>3910</b>	
10 - 173	33	N3480	<b>3380</b>	34B4BEBL-E2	1/4	111	<b>3910</b>	
20 - 345	17	—	<b>3379</b>	34B4BEPM-E1	1/4	111	<b>3910</b>	
3 - 58	153	—	N3372	34B6BEBL-F3	3/8	111	<b>3910</b>	
5 - 86	102	—	N3371	34B6BEBL-F3	3/8	111	<b>3910</b>	
10 - 173	51	N3470	N3370	34B6BEBL-F2	3/8	111	<b>3910</b>	
20 - 345	26	—	<b>3369</b>	34B6BEBL-F1	3/8	111	<b>3910</b>	
<b>Right Angle Gearmotors</b>								
1.7 - 29	37	N3421	N3321	22B4BEBL-3N	1/8	112	<b>3910</b>	
2.5 - 43	37	N3422	<b>3322</b>	22B4BEBL-3N	1/8	112	<b>3910</b>	
5 - 86	35	N3423	N3323	22B4BEBL-3N	1/8	112	<b>3910</b>	
10 - 173	20	<b>3424</b>	N3324	22B4BEBL-3N	1/8	112	<b>3910</b>	
20 - 345	10	N3425	<b>3325</b>	22B4BEBL-3N	1/8	112	<b>3910</b>	
2.5 - 43	46	—	<b>3386</b>	34B3BEBL-5N	1/5	113	<b>3910</b>	
3 - 58	44	—	N3387	34B3BEBL-5N	1/5	113	<b>3910</b>	
5 - 86	37	—	N3388	34B3BEBL-5N	1/5	113	<b>3910</b>	
10 - 173	21	—	N3389	34B3BEBL-5N	1/5	113	<b>3910</b>	
20 - 345	11.6	—	N3390	34B3BEBL-5N	1/5	113	<b>3910</b>	
2.5 - 43	49	N3491	N3391	34B4BEBL-5N	1/4	113	<b>3910</b>	
3 - 58	46	N3492	N3392	34B4BEBL-5N	1/4	113	<b>3910</b>	
5 - 86	46	<b>3493</b>	N3393	34B4BEBL-5N	1/4	113	<b>3910</b>	
10 - 173	26	N3494	N3394	34B4BEBL-5N	1/4	113	<b>3910</b>	
20 - 345	14.8	N3495	N3395	34B4BEBL-5N	1/4	113	<b>3910</b>	
2.5 - 43	52	—	N3396	34B6BEBL-5N	3/8	113	<b>3910</b>	
3 - 58	50	—	N3397	34B6BEBL-5N	3/8	113	<b>3910</b>	
5 - 86	52	—	N3398	34B6BEBL-5N	3/8	113	<b>3910</b>	
10 - 173	40	—	<b>3399</b>	34B6BEBL-5N	3/8	113	<b>3910</b>	
20 - 345	23	—	N3378	34B6BEBL-5N	3/8	113	<b>3910</b>	



<sup>1</sup> NOTE: Model numbers shown in bold type are in stock. "N" model numbers require lead time and minimum quantities.

**MADE IN U.S.A.**

# Accessories

## For Brushless DC Motors and Controls

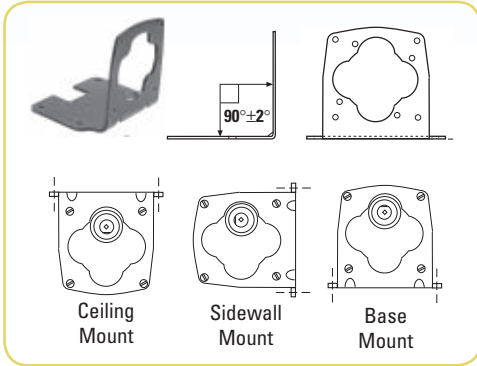

### Motor and Gearmotor "L" Brackets

Model No.	Description	lbs.	Dimensions	Deflection lbs.
0969	Kit for "E" and "F" Gearmotors	2.5	Page 111	200
0970	Kit for "W" Gearmotors	1.75	Page 110	125
0979	Kit for 34B Motors	1	Page 107	25
5968	22B-D, 22B-Z Gearmotors	1.25	Pages 108, 109	50

Most parallel shaft stock gearmotors have a breather hole on top and require that the driveshaft remain at 12 o'clock position with respect to the horizon. See "Mounting Positions" on page 2.

### Other Gearmotor Kits

Model No.	Description	lbs.	Dimensions
0967	Base plate kit for 3F gearmotors	.5	Page 112

### Model 0995 Adaptor Plate

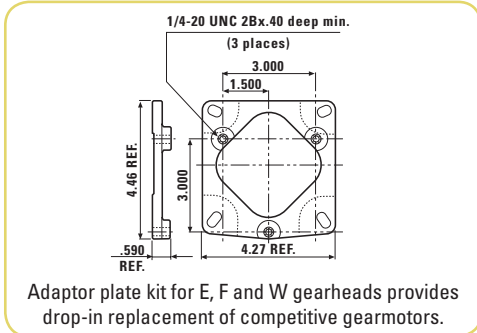

### Model 0993 Aluminum Adaptor Plate

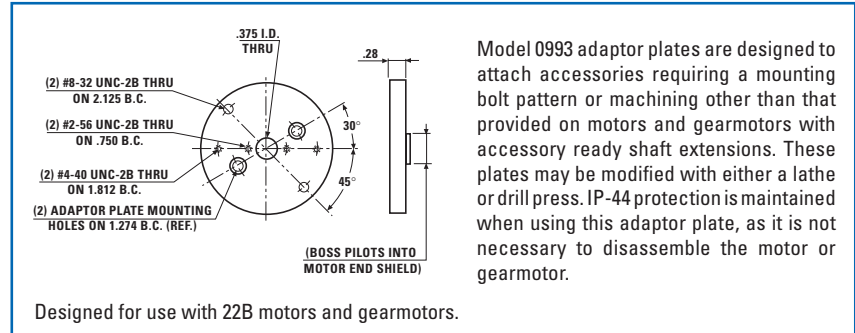

### Encoder Kits

Model Number	Renco Number	Resolution (Pulses per Revolution)	Fits Brushless Bodine Types
0940	RM15D-360-1/4-G6-5CA24-LD-1-C4	360	22B, 34B

- Kits are designed for quick and easy installation to accessory ready models.
- Incremental encoder output may be used for speed verification or motion control.
- 5 VDC, 135 mA Input, TTL/CMOS compatible, 20 mA sink output
- Quadrature, 2 channel output, with 1 index pulse per revolution
- Encoder cable is 24 inches long.
- Terminated with AMP 103650-7 connector.
- 1.50 inch diameter, 0.82 inch long

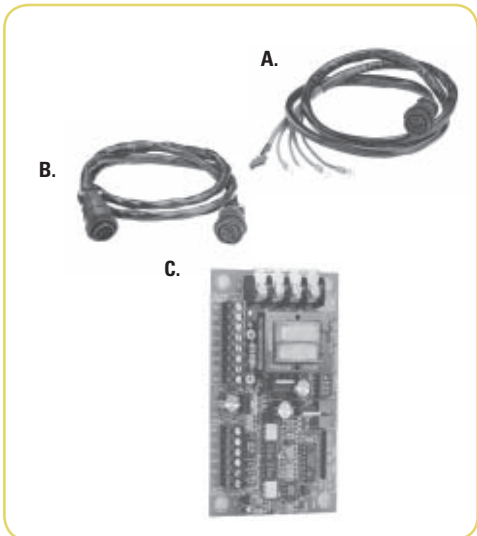

### 115V Brushless Control Accessories

#### A. Model 3983 Connection Cable Assembly

for connecting model 3910, 3921 and 3911 controls to stock 130 V motors. One end of the cable is equipped with a circular connector, the other end is equipped with quick disconnects for phase leads, and a molded connector for the commutation leads. Length: 6 feet.

#### B. Model 3982 Extension Cable

for model 3910, 3911, 3921 and 3912 controls. Extends the cable between the motor and control by six feet. Both ends are equipped with circular connections for easy connection between model 3983 cable assembly or encased control and the motor. Length: six feet.

#### C. MODEL 3984 ANALOG INTERFACE AND ISOLATION MODULE

for model 3910, 3911, 3921 and 3912 controls. Provides Analog interface and isolates controls from system controller input signals which may be at different potentials.

#### Fuse and Speed Potentiometer Kit (not shown)

(Part No. 433 00270) for use with model 3910 control. Contains potentiometer for manually regulating motor speed and an assortment of fuses to cover the range of motors and gearmotors which can be used with the control.

#### Model 0895 Enclosure Sealing Kit (not shown)

seals the model 3912 or model N3913 enclosure to provide IP-44 splash-proof protection.

# Model Number Index

N0039.....	67,96,98	0451.....	53	0650.....	55	0767.....	51
N0040.....	67	0452.....	53	0651.....	55	0771.....	51
0041.....	67,96,98	0453.....	53	0652.....	55	0772.....	51
0042.....	67	0454.....	53	0653.....	55	0774.....	51
0043.....	67,96,98	0455.....	53	0654.....	55	N0775.....	51
0044.....	67	0465.....	60	0655.....	55	0776.....	51
0045.....	67	0466.....	60	0661.....	43,56	0780.....	88,96,97
0047.....	67,96,98	0468.....	60	0662.....	43,56	0781.....	88,96,97
0049.....	67	0469.....	60	0663.....	43,56	0783.....	88,96,97
N0084.....	76	0476.....	54	0664.....	43,56	0784.....	88,96,97
0086.....	76	0477.....	54	0665.....	55	0790.....	89,96,97
0087.....	76	0478.....	54	0666.....	55	0791.....	89,96,97
0088.....	76	0479.....	54	0667.....	55	0810.....	90,96,97
N0089.....	76	0480.....	54	0669.....	55	0815.....	91,96,97
0093.....	77,96,97,99	0481.....	54	0670.....	59	0816.....	93,96,97
0094.....	77,96,97,99	0482.....	54	0671.....	55	N0817.....	93,96,97
0096.....	77,96,97,99	0483.....	54	0672.....	59	0818.....	92,96,97
0098.....	77,96,97,99	0484.....	54	0677.....	59	0830.....	90,96,97
0099.....	77,96,97,99	0485.....	54	0678.....	59	0835.....	91,96,97
N0157.....	71,96,98	0487.....	57	0679.....	55	0836.....	93,96,97
0158.....	71,96,98	0488.....	57	0680.....	55	N0837.....	93,96,97
0159.....	71,96,98	0489.....	57	0681.....	55	0838.....	92,96,97
0160.....	71,96,98	0490.....	57	0683.....	55	0850.....	90,96,97
0161.....	71,96,98	0491.....	57	0685.....	55	0855.....	91,96,97
0162.....	71,96,98	0492.....	57	0691.....	56	0856.....	93,96,97
0163.....	71,96,98	N0511.....	58	0692.....	56	N0857.....	93,96,97
0186.....	70,96,98	0513.....	58	0693.....	56	0858.....	92,96,97
0187.....	70,96,98	N0514.....	58	0694.....	56	0865.....	94,98,99
0188.....	70,96,98	0518.....	58	N0695.....	56	0866.....	94,98,99
0189.....	70,96,98	N0519.....	58	0701.....	46	0867.....	95,98,99
0190.....	70,96,98	0521.....	58	0705.....	46	0888.....	101
0191.....	70,96,98	N0522.....	58	0707.....	46	0889.....	101
0192.....	70,96,98	N0523.....	58	0709.....	46	0890.....	101
0193.....	70,96,98	0524.....	58	0710.....	46	0893.....	101
0194.....	70,96,98	0617.....	60	0712.....	46	0895.....	101,122
0195.....	70,96,98	0618.....	60	0713.....	46	0940.....	101,122
0196.....	70,96,98	0619.....	60	0714.....	46	0941.....	101
0197.....	70,96,98	0620.....	60	0718.....	51	0949.....	100
0198.....	70,96,98	0621.....	44	0719.....	51	0967.....	62,100,122
0199.....	70,96,98	0623.....	60	0722.....	51	0969.....	62,100,122
0251.....	43,49	0624.....	60	0723.....	51	0970.....	62,100,112
0253.....	43,49	0626.....	60	0724.....	51	0978.....	100
0254.....	43,49	0627.....	60	0726.....	51	0979.....	62,122
0255.....	43,49	0629.....	59	N0727.....	51	0980.....	62
0258.....	49	0630.....	59	0728.....	51	0982.....	62
0260.....	49	0632.....	44	0729.....	51	0984.....	62,100
0273.....	49	0633.....	59	0730.....	51	0989.....	62
0274.....	49	0634.....	59	0731.....	51	0990.....	100
0281.....	50	0635.....	55	0732.....	51	0991.....	100
0283.....	50	0636.....	55	0733.....	51	0992.....	101
0284.....	43,50	0637.....	55	0737.....	51	0994.....	62
0285.....	43,50	0639.....	55	0741.....	51	0995.....	62,100
0286.....	50	N0640.....	56	0743.....	51	0997.....	100
0290.....	48	0641.....	56	0744.....	51	N1713.....	46
0291.....	48	0642.....	56	N0746.....	51	1865.....	87
0293.....	48	0643.....	56	0747.....	51	1982.....	62
0295.....	48	0645.....	59	0748.....	51	1984.....	62,100
N0297.....	48	0646.....	59	0749.....	51	N2200.....	25
0299.....	48	0647.....	59	0750.....	51	2201.....	25
0448.....	53	0648.....	59	N0762.....	51	2210.....	29
0449.....	53	0649.....	55	0765.....	51	N2212.....	29

New

e-TORQ™

INTEGRAMOTOR™

Hollow Shaft

Custom

Pacesetter™ Inverter Duty

AC Induction

Permanent Magnet DC

Brushless DC

Index

# Model Number Index

N2214.....	29	3304.....	106,120,121	N3406.....	107,120,121	N3561.....	109,119
2216.....	29	3306.....	107,120,121	3409.....	107,120,121	N3562.....	109,119
2220.....	30	3307.....	107,120,121	N3421.....	112,120,121	N3563.....	109,119
N2222.....	30	3309.....	107,120,121	N3422.....	112,120,121	N3564.....	109,119
N2224.....	30	3314.....	106,120	N3423.....	112,120,121	3565.....	112,119
2226.....	30	3317.....	107,120	3424.....	112,120,121	N3566.....	112,119
N2227.....	30	N3321.....	112,120,121	N3425.....	112,120,121	N3567.....	112,119
N2228.....	30	3322.....	112,120,121	N3426.....	108,120,121	N3568.....	112,119
N2234.....	27	N3323.....	112,120,121	N3427.....	108,120,121	N3569.....	112,119
2235.....	27	N3324.....	112,120,121	N3428.....	108,120,121	N3573.....	111,119
N2236.....	35	3325.....	112,120,121	N3429.....	108,120,121	N3574.....	111,119
2237.....	35	3326.....	108,120,121	N3430.....	108,120,121	N3575.....	111,119
N2238.....	35	3327.....	108,120,121	N3431.....	108,120,121	N3579.....	111,119
2240.....	28	N3328.....	108,120,121	N3433.....	108,120,121	N3580.....	111,119
2244.....	28	3329.....	108,120,121	N3446.....	110,120,121	N3582.....	111,119
2245.....	x	N3330.....	108,120,121	N3447.....	110,120,121	N3583.....	111,119
N2247.....	x	N3331.....	108,120,121	N3449.....	110,120,121	3585.....	111,119
N2248.....	x	3333.....	108,120,121	N3450.....	110,120,121	N3586.....	113,119
2249.....	x	3346.....	110,120,121	N3452.....	110,120,121	N3587.....	113,119
2250.....	31	N3347.....	110,120,121	N3453.....	110,120,121	N3588.....	113,119
2251.....	31	N3349.....	110,120,121	N3455.....	110,120,121	N3589.....	113,119
2252.....	31	N3350.....	110,120,121	N3456.....	110,120,121	N3590.....	113,119
N2253.....	31	3352.....	110,120,121	N3457.....	109,120,121	N3591.....	113,119
N2254.....	31	3353.....	110,120,121	N3458.....	109,120,121	N3592.....	113,119
N2255.....	31	N3355.....	110,120,121	N3459.....	109,120,121	N3593.....	113,119
2260.....	32	N3356.....	110,120,121	N3460.....	109,120,121	N3594.....	113,119
2261.....	32	3357.....	109,120,121	N3461.....	109,120,121	N3595.....	113,119
2262.....	32	3358.....	109,120,121	N3462.....	109,120,121	3600.....	107,119
2263.....	32	N3359.....	109,120,121	N3463.....	109,120,121	3604.....	106,119
2270.....	34	N3360.....	109,120,121	N3470.....	111,120,121	N3609.....	107
2271.....	34	N3361.....	109,120,121	N3480.....	111,120,121	3611.....	110,119
2272.....	34	N3362.....	109,120,121	N3482.....	111,120,121	N3617.....	110,119
2273.....	34	3363.....	109,120,121	3483.....	111,120,121	N3623.....	110,119
2274.....	34	N3364.....	109,120,121	N3485.....	111,120,121	N3624.....	110,119
N2275.....	34	3369.....	111,120,121	N3491.....	113,120,121	N3626.....	108,119
N2280.....	36	N3370.....	111,120,121	N3492.....	113,120,121	N3627.....	108,119
2281.....	36	N3371.....	111,120,121	3493.....	113,120,121	N3628.....	108,119
N2282.....	36	N3372.....	111,120,121	N3494.....	113,120,121	3629.....	108,119
N2283.....	36	3373.....	111,120,121	N3495.....	113,120,121	N3634.....	108,119
N2290.....	33	3374.....	111,120,121	N3500.....	107,119	N3635.....	108,119
N2292.....	33	N3375.....	111,120,121	3502.....	106,119	N3636.....	108,119
N2293.....	33	N3378.....	113,120,121	N3504.....	106,119	N3647.....	110,119
N2294.....	33	3379.....	111,120,121	N3507.....	107,119	N3652.....	110,119
2295.....	26	3380.....	111,120,121	N3509.....	107	N3653.....	110,119
N2296.....	33	3382.....	111,120,121	N3517.....	110,119	N3656.....	110,119
N2297.....	33	3383.....	111,120,121	N3522.....	110,119	N3657.....	109,119
2299.....	26	3385.....	111,120,121	N3523.....	110,119	N3658.....	109,119
N2336.....	13	3386.....	113,120,121	N3524.....	110,119	N3659.....	109,119
N2337.....	13	N3387.....	113,120,121	N3526.....	108,119	N3660.....	109,119
N2338.....	13	N3388.....	113,120,121	N3527.....	108,119	3661.....	109,119
N2470.....	12	N3389.....	113,120,121	N3528.....	108,119	N3665.....	112,119
N2471.....	12	N3390.....	113,120,121	N3529.....	108,119	N3666.....	112,119
N2472.....	12	N3391.....	113,120,121	N3534.....	108,119	3667.....	112,119
N2473.....	12	N3392.....	113,120,121	N3535.....	108,119	N3668.....	112,119
N2475.....	12	N3393.....	113,120,121	N3536.....	108,119	N3669.....	112,119
2628.....	44	N3394.....	113,120,121	N3547.....	110,119	N3680.....	111,119
2982.....	39,42	N3395.....	113,120,121	N3552.....	110,119	N3682.....	111,119
2983.....	39,42	N3396.....	113,120,121	N3553.....	110,119	N3683.....	111,119
2984.....	39,42	N3397.....	113,120,121	N3556.....	110,119	N3685.....	111,119
2987.....	39,42	N3398.....	113,120,121	N3557.....	109,119	N3691.....	113,119
2995.....	40,42	3399.....	113,120,121	N3558.....	109,119	N3692.....	113,119
2996.....	41,42	3404.....	120,121	N3559.....	109,119	N3693.....	113,119
3302.....	106,120,121	3405.....	106	N3560.....	109,119	N3694.....	113,119

# Model Number Index

N3695.....	113,119	4119.....	80	N4558.....	71,96,98	N4762.....	85
3802.....	8	4134.....	81,96,97,99	N4559.....	71,96,98	N4764.....	85
3802.....	8	4135.....	81,96,97,99	N4560.....	71,96,98	N4766.....	85
3804.....	8	4136.....	81,96,97,99	N4561.....	71,96,98	N4791.....	70
3804.....	8	4137.....	81,96,97,99	N4562.....	71,96,98	N4792.....	70
N3826.....	9	4138.....	81,96,97,99	N4563.....	71,96,98	N4793.....	70
3827.....	9	4173.....	74,96,98	N4573.....	74,96,98	N4794.....	70
N3828.....	9	4174.....	74,96,98	N4574.....	74,96,98	N4795.....	70
3829.....	9	4175.....	74,96,98	N4575.....	74,96,98	N4796.....	70
N3834.....	9	4179.....	74,96,98	N4576.....	74,96,98	N4797.....	70
N3835.....	9	4180.....	74,96,98	N4578.....	74,96,98	N4798.....	70
3836.....	9	4181.....	74,96,98	N4579.....	74,96,98	N4799.....	70
N3837.....	9	4182.....	74,96,98	4580.....	74,96,98	N4800.....	69
3857.....	9	4183.....	74,96,98	N4581.....	74,96,98	N4802.....	69
N3858.....	9	4184.....	74,96,98	N4582.....	74,96,98	N4826.....	82
N3859.....	9	4185.....	74,96,98	4583.....	74,96,98	N4827.....	82
3860.....	9	4190.....	74,96,98	N4584.....	74,98	N4828.....	82
N3861.....	9	4191.....	74	4585.....	74,96,98	N4829.....	82
N3862.....	9	4192.....	74	N4594.....	82,96,97,99	4830.....	82
3863.....	9	4193.....	74,96,98	N4596.....	82,96,97,99	N4831.....	82
N3864.....	9	4194.....	82,96,97,99	N4598.....	82,96,97,99	N4832.....	82
N3865.....	10	N4196.....	82,96,97,99	N4599.....	82,96,97,99	N4833.....	82
3866.....	10	4198.....	82,96,97,99	N4601.....	69	N4834.....	81
N3867.....	10	4199.....	82,96,97,99	N4603.....	69	N4835.....	81
3868.....	10	N4302.....	viii	N4634.....	81	N4836.....	81
N3869.....	10	N4303.....	viii	N4635.....	81	N4837.....	81
3905.....	115,119	N4306.....	viii	4636.....	81	N4838.....	81
3907.....	115,119	N4314.....	viii	N4637.....	81	N4860.....	85
3910.....	118,121	N4336.....	viii	N4638.....	81	N4862.....	85
3911.....	116,120	N4421.....	69	N4657.....	71	N4864.....	85
3912.....	117,120	N4422.....	69	N4658.....	71	N4866.....	85
N3913.....	117,120	N4430.....	69,96	N4659.....	71	N4893.....	77
3921.....	116,120	N4432.....	69,96	4660.....	71	N4894.....	77
3982.....	122	4435.....	69,96,98	N4661.....	71	N4896.....	77
3983.....	122	N4437.....	69,96,98	N4662.....	71	N4898.....	77
3984.....	101,122	N4439.....	67,96,98	4663.....	71	N4899.....	77
N4002.....	viii	N4440.....	67	N4673.....	74	N4957.....	71
4003.....	viii	N4441.....	67,96,98	N4674.....	74	N4958.....	71
N4006.....	viii	N4444.....	67	N4675.....	74	N4959.....	71
N4014.....	viii	N4445.....	67	N4676.....	74	N4960.....	71
N4021.....	69	N4460.....	85,96,97,99	N4678.....	74	N4961.....	71
N4022.....	69	N4462.....	85,96,97,99	N4679.....	74	N4962.....	71
N4031.....	69,96	N4464.....	85,96,97,99	N4680.....	74	N4963.....	71
4033.....	69,96	N4466.....	85,96,97,99	N4681.....	74	N4973.....	74
4035.....	69,96,98	N4491.....	70,96,98	N4682.....	74	N4974.....	74
N4036.....	viii	N4492.....	70,96,98	N4683.....	74	N4975.....	74
4037.....	69,96,98	N4493.....	70,96,98	N4684.....	74	N4976.....	74
4060.....	85,96,97,99	N4494.....	70,96,98	4685.....	74	N4978.....	74
4062.....	85,96,97,99	N4495.....	70,96,98	4690.....	70	N4979.....	74
4064.....	85,96,97,99	N4496.....	70,96,98	N4693.....	77	N4980.....	74
4066.....	85,96,97,99	N4497.....	70,96,98	4694.....	77	N4981.....	74
N4093.....	77,96,97,99	N4498.....	70,96,98	N4696.....	77	N4982.....	74
N4094.....	77,96,97,99	N4499.....	70,96,98	N4698.....	77	N4983.....	74
N4096.....	77,96,97,99	N4500.....	82,96,97,99	N4699.....	77	N4984.....	74
N4098.....	77,96,97,99	N4501.....	82,96,97,99	N4726.....	82	N4985.....	74
N4099.....	77,96,97,99	N4502.....	82,96,97,99	N4727.....	82	N4991.....	70
N4100.....	82,96,97,99	N4503.....	82,96,97,99	N4728.....	82	N4992.....	70
4101.....	82,96,97,99	N4534.....	81,96,97,99	N4729.....	82	N4993.....	70
4102.....	82,96,97,99	4535.....	81,96,97,99	N4730.....	82	N4994.....	70
N4103.....	82,96,97,99	4536.....	81,96,97,99	N4731.....	82	N4995.....	70
4116.....	80	N4537.....	81,96,97,99	N4732.....	82	N4996.....	70
4117.....	80	N4538.....	81,96,97,99	N4733.....	82	N4997.....	70
4118.....	80	N4557.....	71,96,98	N4760.....	85	N4998.....	70

New

e-TORQ™

INTEGRAMOTOR™

Hollow Shaft

Custom

Pacesetter™ Inverter Duty

AC Induction

Permanent Magnet DC

Brushless DC

Index

# Model Number Index

N4999.....	70	6127.....	78	N6550.....	73,96,98	N6947.....	73
N5002.....	viii	6128.....	78	N6551.....	73,96,98	N6948.....	73
N5006.....	viii	6134.....	79,97,99	N6552.....	73,96,98	N6949.....	73
N5014.....	viii	6135.....	79,97,99	N6553.....	73,96,98	N6950.....	73
N5036.....	viii	6136.....	79,97,99	N6554.....	73,96,98	N6951.....	73
5219.....	47	6137.....	79,97,99	N6555.....	73,96,98	N6952.....	73
5240.....	47	6138.....	79,97,99	N6556.....	73,96,98	N6953.....	73
5246.....	47	6146.....	73,96,98	N6565.....	72,96,98	N6954.....	73
N5255.....	x	6147.....	73,96,98	N6566.....	72,96,98	N6955.....	73
5257.....	x	6148.....	73,96,98	N6567.....	72,96,98	N6956.....	73
N5258.....	x	6149.....	73,96,98	N6568.....	72,96,98	N6965.....	72
N5259.....	x	6150.....	73,96,98	N6569.....	72,96,98	N6966.....	72
5260.....	61	6151.....	73,96,98	N6573.....	75	N6967.....	72
N5261.....	61	6152.....	73,96,98	N6578.....	75	N6968.....	72
5262.....	61	6153.....	73,96,98	N6579.....	75	N6969.....	72
N5264.....	61	6154.....	73,96,98	6580.....	75	N6973.....	75
5266.....	61	6155.....	73,96,98	6583.....	75	N6978.....	75
N5270.....	61	6156.....	73,96,98	N6584.....	75	N6979.....	75
N5271.....	61	6165.....	72,96,98	6585.....	75	N6980.....	75
N5272.....	61	6166.....	72,96,98	N6591.....	75	N6984.....	75
N5274.....	61	6167.....	72,96,98	6594.....	83	N6985.....	75
N5276.....	61	6168.....	72,96,98	6636.....	79,97,99	N6991.....	75
N5302.....	viii	6169.....	72,96,98	N6638.....	79,97,99	7060.....	17
N5303.....	viii	6173.....	75	N6646.....	73	7062.....	17
N5306.....	viii	6174.....	75	6647.....	73	7064.....	17
5314.....	viii	6175.....	75	N6648.....	73	7066.....	17
N5336.....	viii	6179.....	75	N6649.....	73	7093.....	14
5461.....	52	6180.....	75	N6650.....	73	7094.....	14
5462.....	52	6181.....	75	N6651.....	73	7096.....	14
5463.....	52	6182.....	75	6652.....	73	7098.....	14
5470.....	52	6183.....	75	N6653.....	73	7099.....	14
5471.....	52	6184.....	75	6654.....	73	7138.....	16
5472.....	52	6185.....	75	N6655.....	73	7139.....	16
5473.....	52	6190.....	75	6656.....	73	7159.....	71
5474.....	52	6191.....	75	N6665.....	72	7466.....	18
5625.....	44	6193.....	75	N6666.....	72	N8002.....	viii
5968.....	62,100,122	6194.....	83	N6667.....	72	N8003.....	viii
5982.....	62	6196.....	83	N6668.....	72	8006.....	viii
6021.....	68	6198.....	83	N6669.....	72	N8014.....	viii
6022.....	68	6199.....	83	N6673.....	75	N8036.....	viii
6023.....	x	N6323.....	x	N6678.....	75	N8502.....	viii
6024.....	68	6345.....	x	N6679.....	75	N8503.....	viii
6034.....	68	N6356.....	x	6680.....	75	N8506.....	viii
6035.....	68	N6393.....	x	6684.....	75	N8514.....	viii
6037.....	68	N6422.....	68	6685.....	75	N8536.....	viii
N6045.....	x	N6423.....	x	N6691.....	75	N8765.....	19
N6056.....	x	N6424.....	68	N6734.....	15	N8766.....	19
6060.....	84	6434.....	68	6735.....	15	N8767.....	19
6062.....	84	6435.....	68	N6736.....	15	N8768.....	19
6064.....	84	N6445.....	x	N6737.....	15	N8769.....	19
6066.....	84	6456.....	x	N6738.....	15	N8865.....	19
6093.....	x	N6493.....	x	6757.....	73	N8866.....	19
6116.....	78	6535.....	79,97,99	N6823.....	x	N8867.....	19
6117.....	78	6542.....	79,96,97,99	6835.....	79,97,99	N8868.....	19
6118.....	78	N6546.....	73,96,98	6845.....	x	N8869.....	19
6119.....	78	N6547.....	73,96,98	N6856.....	x	N60500520.....	6
6125.....	78	N6548.....	73,96,98	N6893.....	x	N60501390.....	6
6126.....	78	N6549.....	73,96,98	N6946.....	73	N60501400.....	6



Metric AC and DC products have been designed with international standards in mind.

The 230 volt, 50 hertz windings can be operated satisfactorily on any nominal system voltage between 220 and 240 volts to accommodate almost all international power supply requirements.

DC motors and gearmotors are rated for 180 volt operation and are available with "System Matched" Bodine controls in either open chassis or waterproof enclosures.

In addition to our broad range of stock and standard international products, all of our products can be customized for any voltage or frequency requirements.

Splash proof terminal boxes are standard on most AC products and are an available option on DC products. Mounting and shaft configurations designed for common metric sizes provide convenient interfacing capability.

Metric motors and gearmotors are designed to meet most international industrial requirements. Their nameplates bear an IEC-34-1 designation. Many stock products are also CSA certified. Bodine metric motors and gearmotors also bear the CE mark.

**For complete specifications on all our  
International and Metric Products, visit our website at  
[Bodine-Electric.com](http://Bodine-Electric.com).**

# QUALITY IN MOTION®

**Bodine Electric is committed to complete customer satisfaction and continuous improvement. As a team, we are dedicated to doing things right the first time, conforming to all known requirements, and providing on-time defect free products.**

## Warranty

The Bodine Electric Company warrants all products it manufactures to be free of defects in workmanship and materials when used under Normal Operating Conditions and when applied in accordance with nameplate specifications.

When Bodine motors and gearmotors have been purchased with, and used with appropriately applied Bodine controls, this warranty shall be in effect for a period of twenty-four months from date of purchase or thirty months from date of manufacture, whichever comes first. Bodine motors and gearmotors used without controls or with non-Bodine controls and Bodine controls used with non-Bodine motors and gearmotors are covered by standard twelve-month warranty period.

The Bodine Electric Company will repair or replace at its option, any of its products which has been found to be defective and is within the warranty period, provided that the product is shipped freight prepaid, with previous authorization, to Bodine's plant in Chicago, Illinois 60618 U.S.A., or to the nearest Bodine Authorized Service Center. At its option, all return shipments are F.O.B. Bodine's plant or Authorized Service Center. Bodine is not responsible for removal, installation, or any other incidental expenses incurred in shipping the products to or from Bodine.

The Distributor return policy for individual Bodine Distributors supersedes this policy.

This warranty is in lieu of any other expressed or implied warranty - including (but not limited to) any implied warranties of merchantability and/or fitness for a particular use or purpose.

Bodine's liability under this warranty shall be solely limited to repair or replacement of the Bodine product within the warranty period and Bodine shall not be liable, under any circumstances, for any consequential, incidental or indirect damages or expenses associated with the warranted products.

Commutator and/or brush wear and its associated effects is normal occurrence and are not covered by this warranty.

Proof of purchase of motor or gearmotor and matching control as a system must be provided with any claim.



Special Mounting Bases



Hollow Shaft



Custom Windings



Custom Rotors

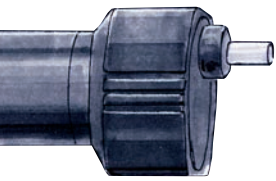

Metric Mounting



Encoders

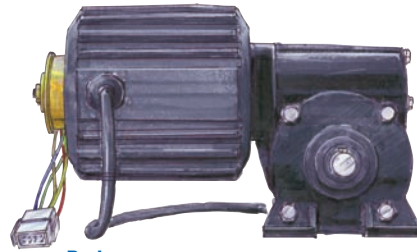

Brakes



Integrated Controls

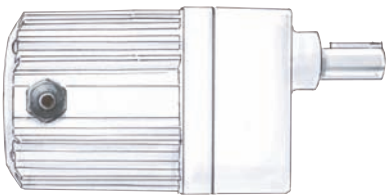

Custom Colors



Custom Cables and Connections

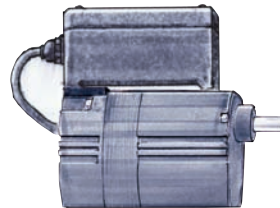

Customized Terminal Boxes

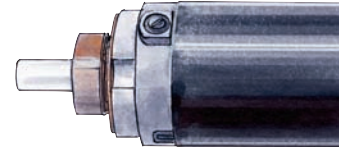

Shaft Extensions

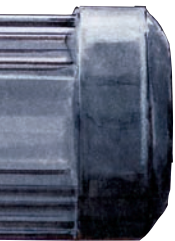

Fan Cooled or Non-Fan Cooled

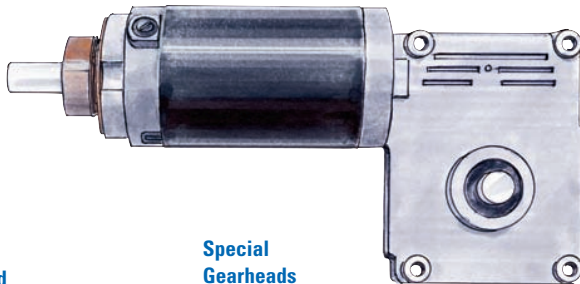

Special Gearheads

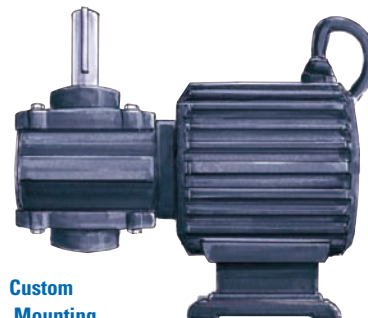

Custom Mounting

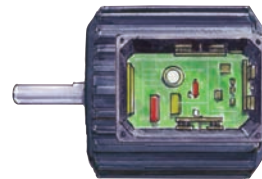

Built-in Custom Speed Controls

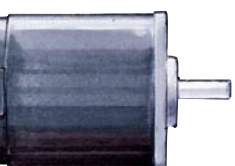

Special Face Mounting



Special Output Shafts

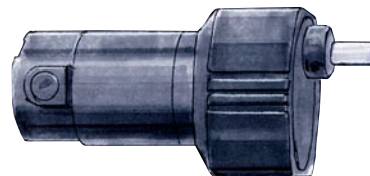

Modified Gear Ratios

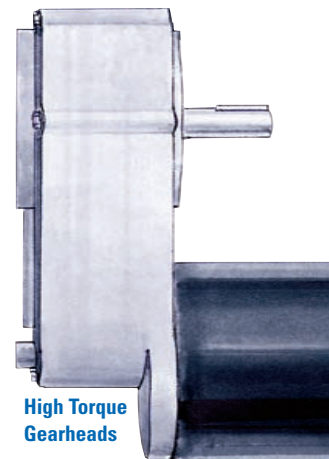

High Torque Gearheads

# At Bodine, Custom Is Standard

*Unlimited Design Solutions*

Advanced design tools and flexible manufacturing processes make it possible for us to cost-effectively design and build the widest selection of custom motors, gearmotors, and controls in the industry.

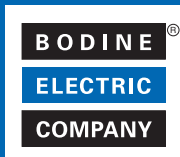

With over 1,000 stock motors, gearmotors and controls, and an infinite number of custom modification options, the variations of Bodine products for your application is truly endless.

*see page 20 for more custom solutions.*

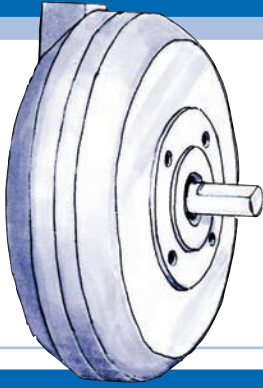

### **e-TORQ™**

#### ***Unique High-Performance Drive System***

The e-TORQ motors employ a unique electromagnetic design to improve efficiency, minimize size, and maximize torque. They are ideal for OEM applications where high torque, very compact design, enclosed construction, and economy are necessary.

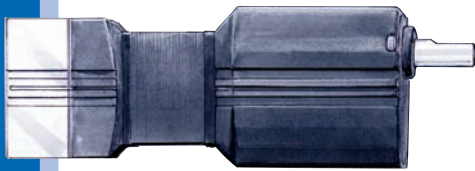

### **INTEGRAmotor™**

#### ***Brushless DC Motor or Gearmotor with built-in PWM control***

The *INTEGRAmotor*, 24V, Brushless DC products integrate three motion control components into one compact package. The perfect match of motor, speed control, and gearhead provide simplified wiring, reduced panel space, faster assembly times, and lower system costs.

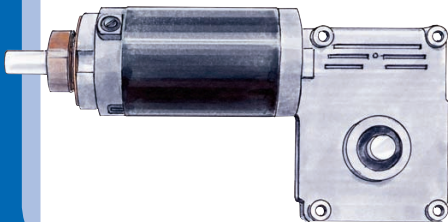

### **Custom Solutions**

#### ***Your specifications, no compromises***

From special performance requirements to unique mounting configurations—and everything in between—the Bodine MotionPro team can design a custom solution to match your exact specifications. Nearly half of all the motors we make are customized, and all of them come with the end-use reliability we're famous for.